

# APX 7000

Operating Manual



Copyright by Carl Valentin GmbH / 7997505.0618

Information on the scope of delivery, appearance, performance, dimensions and weight reflect our knowledge at the time of printing.

We reserve the rights to make modifications.

All rights, including those regarding the translation, are reserved.

No part of this document may be reproduced in any form (print, photocopy or any other method) or edited, copied or distributed electronically without written permission from Carl Valentin GmbH.

Due to the constant further development of our devices discrepancies between manual and device can occur.

Please check [www.carl-valentin.de](http://www.carl-valentin.de) for the latest update.

### **Trademarks**

All named brands or trademarks are registered brands or registered trademarks of their respective owners and may not be separately labelled. It must not be concluded from the missing labelling that it is not a registered brand or a registered trademark.

The applicator comply with the following safety guidelines:

- CE EG Low-Voltage Directive (2006/95/EC)
- EG Electromagnetic Compatibility Directive (2004/108/EG)
- EG Machinery Directive (2006/42/EG)



### **Carl Valentin GmbH**

Postfach 3744  
78026 Villingen-Schwenningen  
Neckarstraße 78 – 86 u. 94  
78056 Villingen-Schwenningen

Phone +49 7720 9712-0  
Fax +49 7720 9712-9901

E-Mail [info@carl-valentin.de](mailto:info@carl-valentin.de)  
Internet [www.carl-valentin.de](http://www.carl-valentin.de)

## Table of Contents

<b>Table of Contents</b> .....	<b>3</b>
<b>1 Introduction</b> .....	<b>5</b>
1.1 General Instructions .....	5
1.2 Intended Use .....	6
<b>2 Safety Instructions</b> .....	<b>7</b>
2.1 Safety Marking.....	8
2.2 Operating Conditions .....	9
<b>3 Product Description</b> .....	<b>13</b>
3.1 Applying the Labels .....	13
3.2 Applicator Overview.....	14
3.3 Pads .....	17
3.4 Removing of Covers .....	18
<b>4 Technical Data</b> .....	<b>19</b>
<b>5 Installation</b> .....	<b>21</b>
5.1 Scope of Delivery .....	21
5.2 Installation of Applicator to the Printing System .....	22
5.3 Piercing the Universal Tamp Pad.....	23
5.4 Preparing for Using a Sprint-Mounted Tamp Pad.....	24
5.5 Installing the Pad .....	25
5.6 Installation of Connections .....	26
<b>6 Options</b> .....	<b>27</b>
6.1 Quick Apply .....	27
6.2 Shock Absorber .....	28
6.3 Product Sensor.....	29
<b>7 Configuration</b> .....	<b>31</b>
7.1 Configuration Parameter .....	31
7.2 Settings in Printing System Function Menu .....	33
<b>8 Signal Diagrams</b> .....	<b>39</b>
8.1 Print – Apply (w/o transverse axis).....	39
8.2 Apply – Print (w/o transverse axis).....	40
<b>9 Mechanical Adjustments</b> .....	<b>41</b>
9.1 Aligning the Pad .....	41
9.2 Adjusting the Parallelism between Pad and Dispense Edge .....	43
9.3 Opening the Holes on the Blow Tube.....	43
9.4 Aligning the Blow Tube.....	44
9.5 Adjusting the Stopper .....	45
<b>10 Pneumatic Adjustments</b> .....	<b>47</b>
10.1 Control Valves .....	47
10.2 Adjusting the Pad Movement Speed .....	49
10.3 Adjusting Vacuum and Supporting Air.....	50
<b>11 Operation</b> .....	<b>53</b>
11.1 Loading Labels and Transfer Ribbon .....	53
11.2 Setting the Dispenser Moden .....	54
11.3 Standard Operation .....	55
<b>12 Applicator Interface</b> .....	<b>55</b>
12.1 Printer internal circuitry.....	56
12.2 Pin assignment D-Sub bushing .....	57
12.3 Examples.....	59
12.4 Precautions.....	60

<b>13</b>	<b>Error Messages</b> .....	<b>61</b>
13.1	Error Messages of the Printing System.....	61
13.2	Error Messages of the Applicator .....	61
13.3	Troubleshooting pressure /vacuum control .....	62
<b>14</b>	<b>Environmentally-Friendly Disposal</b> .....	<b>65</b>
<b>15</b>	<b>Index</b> .....	<b>67</b>

# 1 Introduction

## 1.1 General Instructions

Basic information and warning references with the corresponding signal words for the danger level are as follows specified in this manual:



**DANGER** identifies an extraordinarily great and immediate danger which could lead to serious injury or even death.



**WARNING** identifies a possible danger would could lead to serious bodily injury or even death if sufficient precautions are not taken.



**WARNING** of cutting injuries.  
Pay attention that cutting injuries caused by blades, cutting devices or sharp-edged parts are avoided.



**WARNING** of hand injuries.  
Pay attention that hand injuries caused by closing mechanical parts of a machine/equipment are avoided.



**WARNING** of hot surfaces.  
Pay attention so as not to come into contact with hot surfaces.



**CAUTION** indicates a potentially dangerous situation which could lead to moderate or light bodily injury or damage to property.



**NOTICE** gives you tips. They make a working sequence easier or draw attention to important working processes.



Gives you tips on protecting the environment.



Handling instruction



Optional accessories, special fittings

Date

Information in the display

## 1.2 Intended Use

The print module is a state-of-the-art device which complies with the recognized safety-related rules and regulations. Despite this, a danger to life and limb of the user or third parties could arise and the print module or other property could be damaged while operating the device.

The print module may only be used while in proper working order and for the intended purpose. Users must be safe, aware of potential dangers and must comply with the operating instructions. Faults, in particular those which affect safety, must be remedied immediately.

The print module is solely intended to print suitable media which have been approved by the manufacturer. Any other or additional use is not intended. The manufacturer/supplier is not liable for damage resulting from misuse. Any misuse is at your own risk.

Intended used includes heeding the operating manual, including the maintenance recommendations/regulations specified by the manufacturer.



### **NOTICE!**

The complete documentation is included in the scope of delivery on CD ROM and can also currently be found in the internet.

## 2 Safety Instructions

- Before mounting the delivered components disconnect the printing system from the power supply and close the shutoff valve at the applicator.
- Couple the applicator to devices using extra low voltage only.
- Before making or undoing connections, switch off all devices involved (computer, printer, accessories etc.).
- In operation, moving parts are easily accessible. This applies especially for the zone, where the pad is moved between the starting and the labelling position. During operation do not reach into that zone and keep long hair, loose clothes, and jewellery distant.  
Before any manipulations in those areas, close the shutoff valve.
- Operate the applicator in a dry environment only and do not get it wet (sprayed water, mist etc.).
- Do not operate the applicator in explosive atmosphere and not in proximity of high voltage power lines.
- Operate the applicator only in an environment protected against abrasive dust, swarf and other similar impurity.



### NOTICE!

With the open printing unit (due to construction) the requirements of EN60950-1 regarding fire protection casing are not fulfilled. These must be ensured by the installation into the end device.

- Maintenance and servicing work can only be carried out by trained personnel.
- Operating personnel must be trained by the operator on the basis of the operating manual.
- Carry out only the actions described in these operating instructions. Any work beyond this may only be performed by especially trained personnel or service technicians.
- Unauthorized interference with electronic modules or their software can cause malfunctions.
- Other unauthorized work or modifications to the applicator can endanger operational safety.
- There are warning stickers on the applicator that draw your attention to dangers. Therefore the warning stickers are not to be removed as then you and others cannot be aware of dangers and may be injured.
- When incorporating the unit into the overall system, make sure that safety precautions are taken so that no-one is able to reach into the working area.
- The applicator must be integrated with the Emergency Stop circuit when it is incorporated into the overall machine.

**CAUTION!**

Damages of the plunger rod, cylinder tube or the seals caused by lateral forces that affect the plunger rod of the cylinder. This can lead to a reduction of lifetime and to leakages up to destruction of the cylinder.

⇒ Lateral forces must be avoided necessarily.

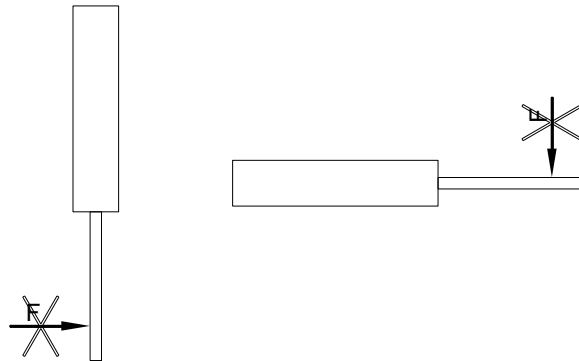
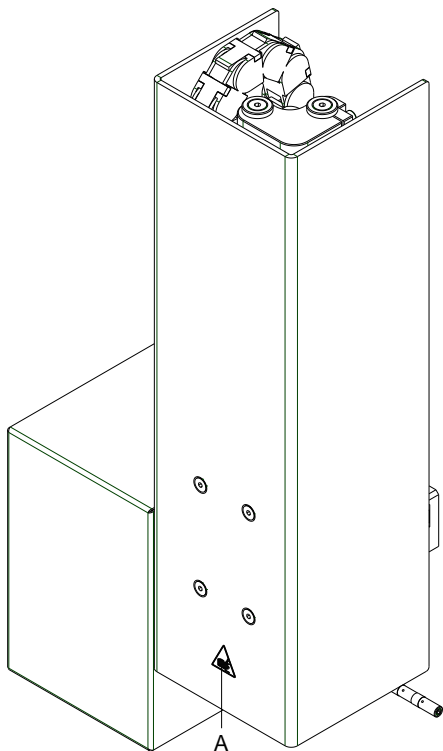
**2.1 Safety Marking**

A = Risk of crushing due to the movement of the pad

**CAUTION!**

There is a risk of injury due to the movement of the pad downwards and back up again.

- ⇒ Do not reach into the working area of the pad.
- ⇒ Keep hair, loose clothing and items of jewellery out of this area.
- ⇒ When incorporating the unit into the overall system, safety precautions must be taken so that no-one is able to reach into the working area.

**Figure 1**



## 2.2 Operating Conditions

**Before initial operation and during operation** these operating conditions have to be observed to guarantee safe and interference-free service of our printing systems.

Therefore please carefully read these operating conditions.

Shipment and storage of our printing systems are **only** allowed in original packing.

Installation and initial operation of printing system is only allowed if operating conditions were **fulfilled**.

Commissioning is prohibited until it can be established that, where relevant, the machine into which the partly completed machinery is to be incorporated complies with the provisions of Machinery Directive 2006/42/EC.

Initial operation, programming, operation, cleaning and service of our printing systems are only recommended after careful study of our manuals.

Operation of printing system is only allowed by especially trained persons.



### NOTICE!

Perform trainings regularly.

These indications are also valid for someone else's equipment supplied by us.

Only use original spare and exchange parts.

### Conditions for installation place

The installation place of printing system should be even, free of vibration and currents of air are to be avoided.

The printing systems have to be installed to ensure optimal operation and servicing.

### Installation of power supply

The installation of the power supply to connect our printing systems has to be effected according to the international rules and regulations, especially the recommendations of one of the three following commissions:

- International Electronic Commission (IEC)
- European Committee for Electro technical Standardisation (CENELEC)
- Verband Deutscher Elektrotechniker (VDE)

Our printing systems are constructed according to VDE and have to be connected to a grounded conductor. The power supply has to be equipped with a grounded conductor to eliminate internal interfering voltage.

**Technical data of power supply**

Power line voltage and power line frequency: See type plate

Allowable tolerance of power line voltage:  
+6% ... -10% of nominal value

Allowable tolerance of power line frequency:  
+2% ... -2% of nominal value

Allowable distortion factor of power line voltage:  $\leq 5\%$

**Anti-interference measures**

In case your net is infected (e.g. by using thyristor controlled machines) anti-interference measures have to be taken. You can use one of the following possibilities:

- Provide separate power supply to our printing systems.
- In case of problems please connect capacity-decoupled isolation transformer or similar interference suppressor in front of our printing systems.

**Stray radiation and immunity from disturbance**

Emitted interference according to EN 61000-6-4: 2007 industrial sector

- Interference voltage to wires according to EN 55011: 2009 + A1: 2010
- Interference field power according to EN 55011: 2009 + A1: 2010
- System perturbation according to EN 61000-3-2: 2006 + A1: 2009 + A2: 2009
- Flicker according to EN 61000-3-3: 2013

Immunity to interference according to 61000-6-2: 2006 +A11: 2009 + A1: 2010 industrial sector

- Stray radiation against discharge of static electricity according to EN 61000-4-2: 2009
- Electromagnetic fields according to EN 61000-4-3: 2006 + A1: 2008 + A2: 2010
- Fast transient burst according to EN 61000-4-4: 2012
- Surge according to EN 61000-4-5: 2006
- High-frequency tension according to EN 61000-4-6: 2009
- Magnetic field immunity EN 61000-4-8: 2010
- Voltage interruption and voltage drop according to EN 61000-4-11: 2004

**NOTICE!**

This is a machine of type A. This machine can cause interferences in residential areas; in this case it can be required from operator to accomplish appropriate measures and be responsible for it.

**Connecting lines to external machines**

All connecting lines have to be guided in shielded lines. Shielding has to be connected on both sides to the corner shell.

It is not allowed to guide lines parallel to power lines. If a parallel guiding cannot be avoided a distance of at least 0.5 m has to be observed.

Temperature of lines between:  $-15 \dots +80 \text{ }^{\circ}\text{C}$ .

It is only allowed to connect devices which fulfil the request 'Safety Extra Low Voltage' (SELV). These are generally devices which are checked corresponding to EN 60950.

**Installation of data lines**

The data cables must be completely protected and provide with metal or metallised connector housings. Shielded cables and connectors are necessary, in order to avoid radiant emittance and receipt of electrical disturbances.

**Allowable lines**

Shielded line:  $4 \times 2 \times 0,14 \text{ mm}^2$  (  $4 \times 2 \times \text{AWG } 26$  )  
 $6 \times 2 \times 0,14 \text{ mm}^2$  (  $6 \times 2 \times \text{AWG } 26$  )  
 $12 \times 2 \times 0,14 \text{ mm}^2$  (  $12 \times 2 \times \text{AWG } 26$  )

Sending and receiving lines have to be twisted in pairs.

Max. Leitungslängen:

with interface V 24 (RS-232C) - 3 m (with shielding)  
 with Centronics - 3 m (with shielding)  
 USB - 5 m  
 Ethernet - 100 m

**Air convection**

To avoid inadmissible heating, free air convection has to be ensured.

**Limit values**

Protection according IP: 20

Ambient temperature  $^{\circ}\text{C}$  (operation): Min. +5 Max. +35

Ambient temperature  $^{\circ}\text{C}$  (storage): Min.  $-25$  Max. +60

Relative air humidity % (operation): Max. 80

Relative air humidity % (storage): Max. 80  
 (bedewing of printing systems not allowed)

**Guarantee**

We do not take any responsibility for damage caused by:

- Ignoring our operating conditions and operating manual.
- Incorrect electric installation of environment.
- Building alterations of our printing systems.
- Incorrect programming and operation.
- Not performed data protection.
- Using of not original spare parts and accessories.
- Natural wear and tear.

When (re)installing or programming our printing systems please control the new settings by test running and test printing. Herewith you avoid faulty results, reports and evaluation.

Only specially trained staff is allowed to operate the printing systems.

Control the correct handling of our products and repeat training.

We do not guarantee that all features described in this manual exist in all models. Caused by our efforts to continue further development and improvement, technical data might change without notice.

By further developments or regulations of the country illustrations and examples shown in the manual can be different from the delivered model.

Please pay attention to the information about admissible print media and the notes to the printing system maintenance, in order to avoid damages or premature wear.

We endeavoured to write this manual in an understandable form to give you as much as possible information. If you have any queries or if you discover errors, please inform us to give us the possibility to correct and improve our manual.

### 3 Product Description

The applicator APL 100 is an optional device to use with printing systems of ILX series for automatically applying the printed label onto the product.

The labels are transferred with a pad, which moves between the two positions, starting position and labelling position, by a compressed-air driven pneumatic cylinder.

In the starting position, the label is picked up from the printing system. A sensor at the cylinder signals when the pad is in the starting position.

The label is removed from the carrier ribbon directly at the dispense edge of the printing system. It is sucked on the pad by a vacuum via drillings at the bottom of the pad.

For support, the label is also blown against the pad (supporting air) with an air current coming from a blow tube.

The correct transfer of the label is controlled by a vacuum sensor.

Next, the pad is moved down into the labelling position. Reaching the labelling position is confirmed by another sensor (labelling position sensor).

In the labelling position the label is transferred onto the product.

The supporting air and the vacuum as well as the speed of the cylinder are adjustable. That way the applicator can be adapted to different label materials and sizes.

The pressure for the cylinder movement is reduced in relation to the operating pressure of the entire labelling machine so that the danger of injury is reduced as much as possible.

To avoid contamination within the vacuum channels they are cleaned by air pressure impulse at the end of each application.

For integration into a superordinated process the printing systems are equipped with 'Dispenser I/O'.

#### 3.1 Applying the Labels

For applying the labels on the products, there are three different possibilities available:

##### **Stamp on**

The label is pressed directly onto the product.

##### **Blow on**

The pad moves to a pre-adjusted position approximately 10 mm away from the product. The label is blown onto the product by an air stream.

##### **Roll on**

In the starting position the label is forwarded until touching the roller of the roll on pad. At the labelling position the roller is pressed onto the product. Then the label is applied and rolled on by the movement of the product.

### 3.2 Applicator Overview

#### Front view

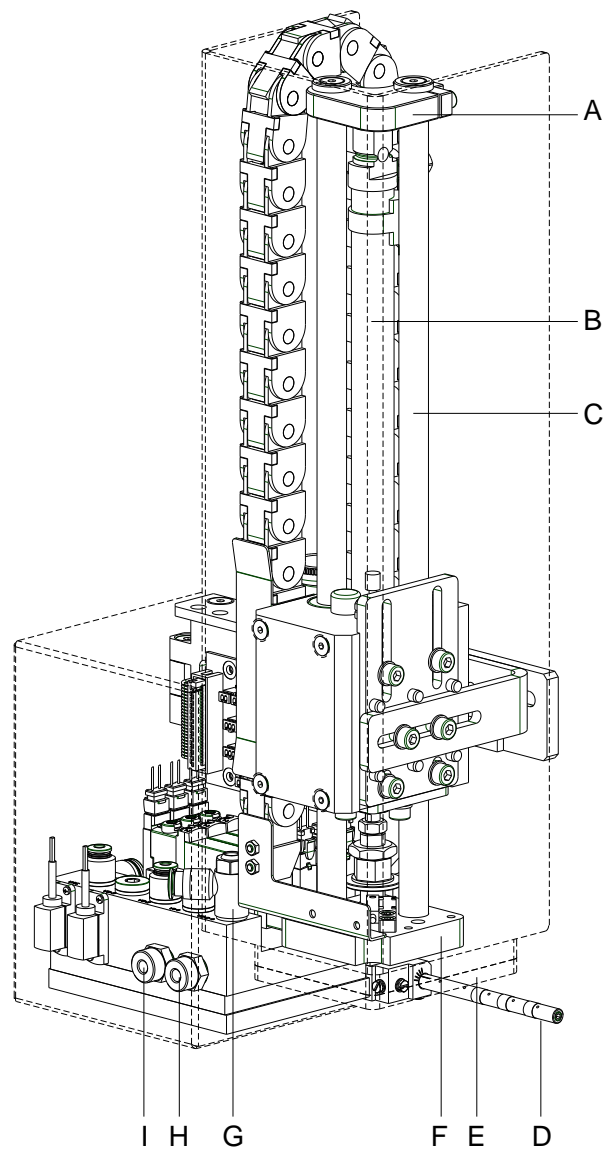

**Figure 2**

- A = Stopper for the operation mode "blow on"
- B = Pneumatic cylinder
- C = Cylinder unit
- D = Blow tube for supporting air
- E = Pad (application specific)
- F = Pad holder
- G = Throttling back valve 'blowing air'
- H = Throttling back valve 'vacuum'
- I = Throttling back valve 'supporting air'

## Rear view

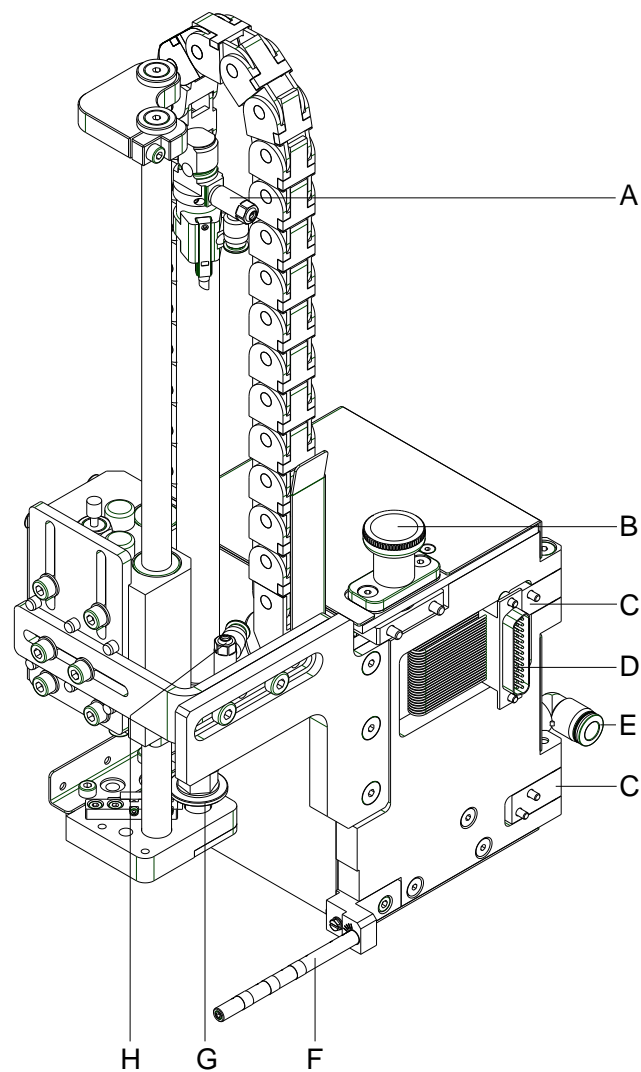

**Figure 3**

- A = Throttling back valve 'cylinder' (top)
- B = Locking pin with interlock
- C = Hinge for fixing the applicator to the printing system
- D = Interface to the printing system
- E = Compressed air connector
- F = Blow tube for supporting air
- G = Pad holder
- H = Throttling back valve 'cylinder' (bottom)

**Service unit -  
right version**

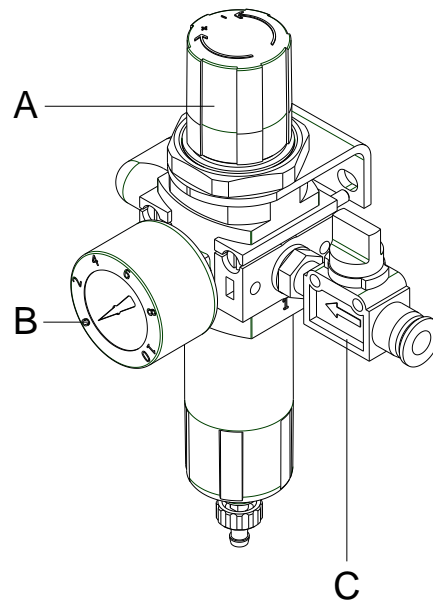

**Figure 4**

- A = Adjusting knob of pressure control valve with filter
- B = Manometer
- C = Shut-off valve

**Service unit -  
left version**

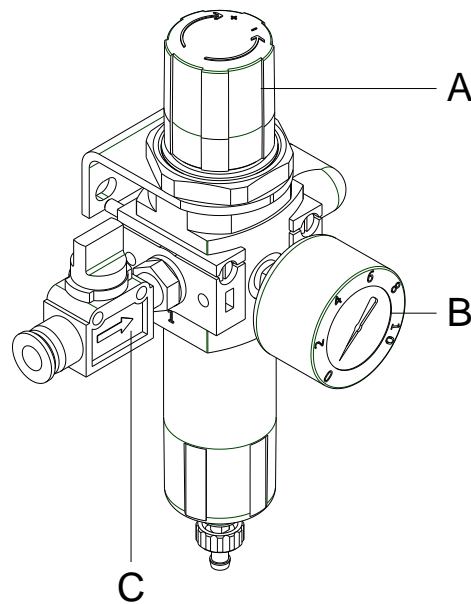

**Figure 5**

- A = Adjusting knob of pressure control valve with filter
- B = Manometer
- C = Shut-off valve



### 3.3 Pads

#### Tamp pad

Universal tamp pad

Standard size:  
70 x 85 mm

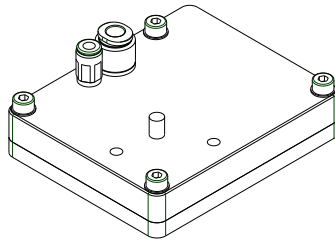

**Figure 6**

Spring-mounted universal tamp pad

Standard size:  
90 x 120 mm

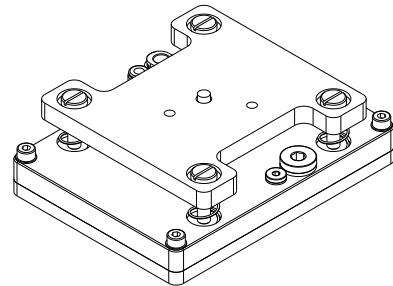
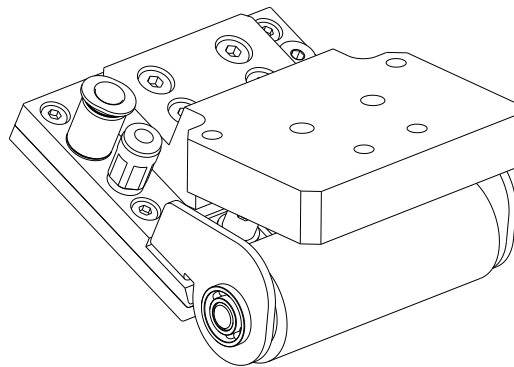

**Figure 7**

Universal tamp are available in different standard sizes. According to the size of the label the holes may be pierced by the customer. For that purpose a piercing pin is included in the delivery contents.

On request, tamp pads customized to the label sized are delivered.

#### Roll-on pad



**Figure 8**

Roll-on pads are only produced on request customized to the label size.

#### Blow pad (w/o teflon tape)

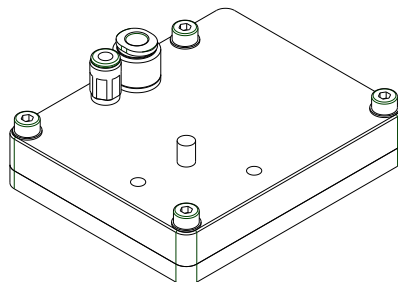

**Figure 9**

Blow pads are only produced on request customized to the label size.

### 3.4 Removing of Covers

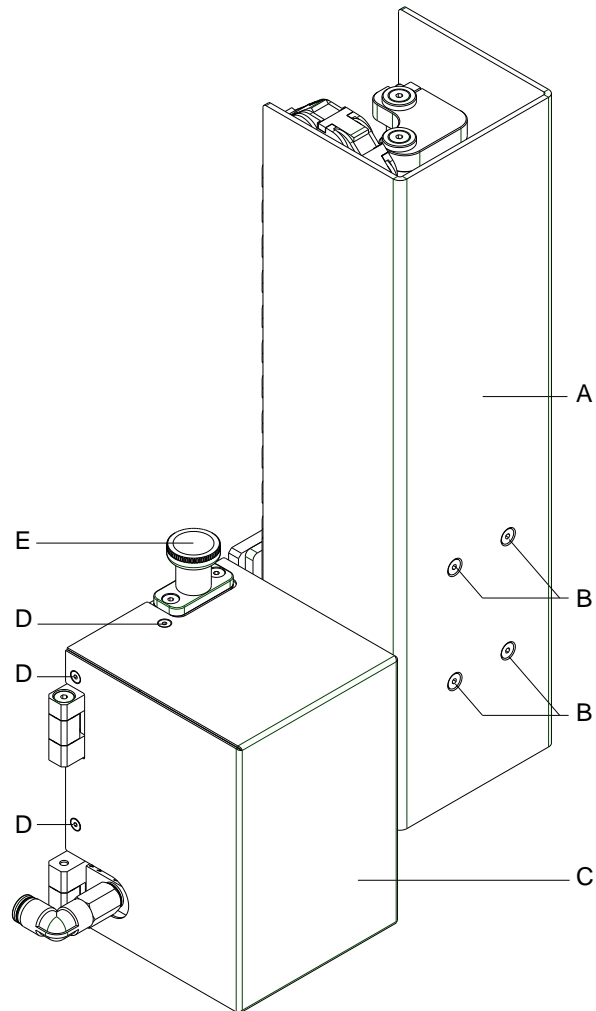

**Figure 10**

**Removing the  
pneumatic cover**

1. Loosen screws (B).
2. Remove the cover (A).

**Removing the  
electronics cover**

1. Loosen screws (D).
2. Remove the cover (C).

## 4 Technical Data

Label transfer / Operating modes	Stamp on	Blow on	Roll on
Label width			
ILX 5X	20 ... 56 mm	20 ... 56 mm	20 ... 56 mm
ILX 8X	20 ... 86 mm	20 ... 86 mm	20 ... 86 mm
ILX 10X	20 ... 112 mm	20 ... 112 mm	20 ... 112 mm
Label height (mm)	15 ... 210 mm	15 ... 100 mm	70 ... 210 mm
Label height universal pad	15 ... 80 mm	15 ... 80 mm	70 mm
Utilizable cylinder stroke			
200 mm cylinder	170 mm	170 mm	200 mm
300 mm cylinder	270 mm	270 mm	300 mm
400 mm cylinder	370 mm	370 mm	400 mm
500 mm cylinder	470 mm	470 mm	500 mm
Compressed air pressure	5 bar	5 bar	5 bar
Product surface	eben	eben	eben
Product height variable	✓	-	✓
Product height fixed	✓	✓	✓
Product fixed	✓	✓	-
Product linear movement	-	✓	✓
Labelling from top	✓	✓	✓
Labelling from bottom	✓	✓	✓
Labelling from the side	✓	✓	✓
Retraction depth	25 mm	-	-
Direction	right and left version		
Compressed air control/vacuum control	available		
Service unit	filter regulation with manometer and shut-off valve		
Voltage supply/current supply	by label printing system		
Dimensions (w x h x d)	237 x 423 x 126 mm		
APX 7020	237 x 423 x 126 mm		
APX 7030	237 x 523 x 126 mm		
APX 7040	237 x 623 x 126 mm		
APX 7050	237 x 723 x 126 mm		
Weight	5 kg*		

\* measured by APX 7020



## 5 Installation

### 5.1 Scope of Delivery



#### NOTICE!

Please keep the original packaging in case the applicator must be returned.

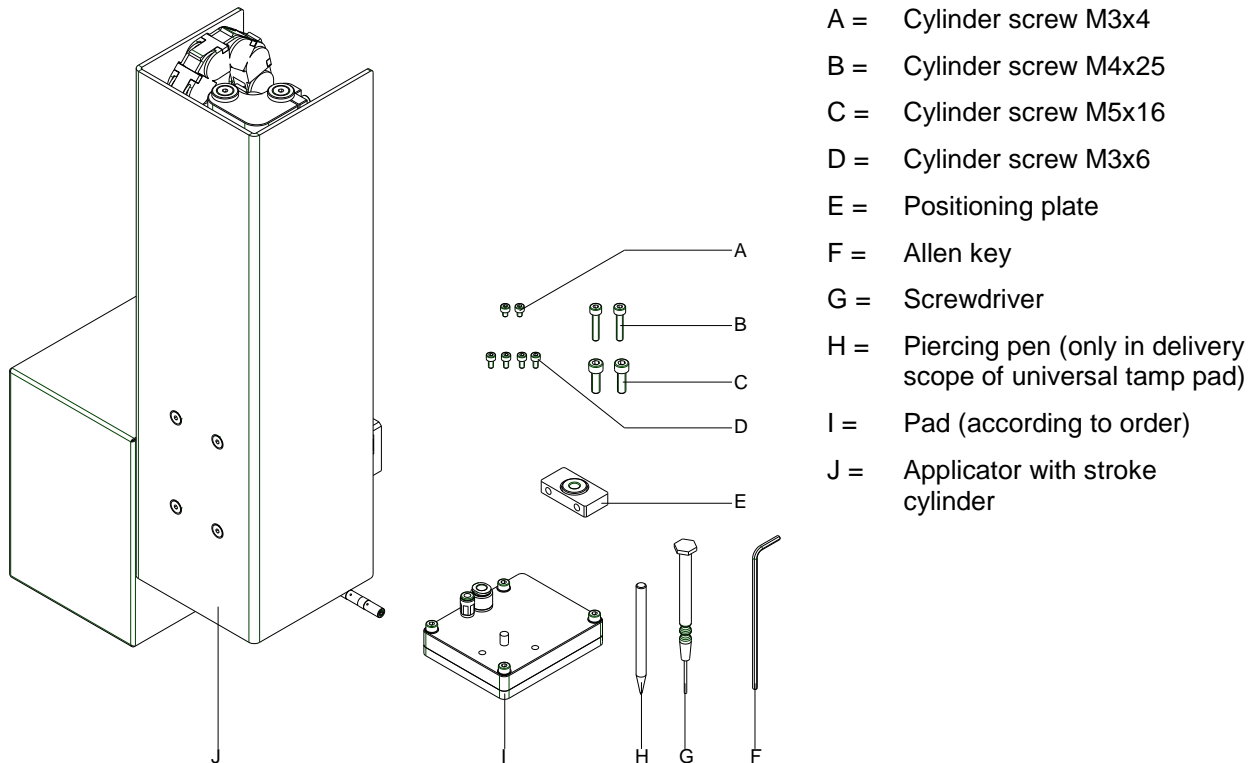

Figure 11



#### CAUTION!

The printing system and the applicator can be damaged by moisture and water.

⇒ Set up the printing system with applicator only in dry locations protected from splash water.

## 5.2 Installation of Applicator to the Printing System



### CAUTION!

Danger of injury by inadvertent move out of the cylinder.

- ⇒ Disconnect the printing system from the power supply before mounting the applicator.
- ⇒ Connect the compressed air only after mounting the applicator to the printing system.

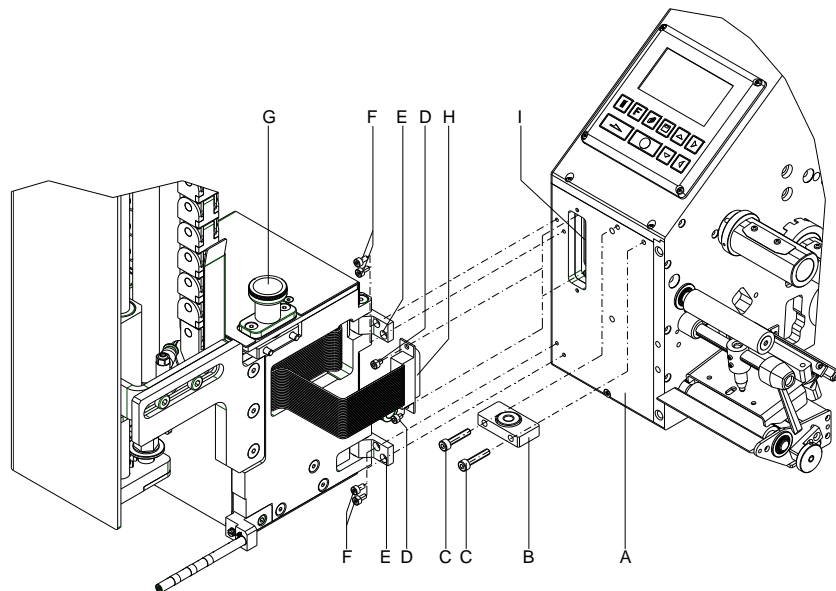
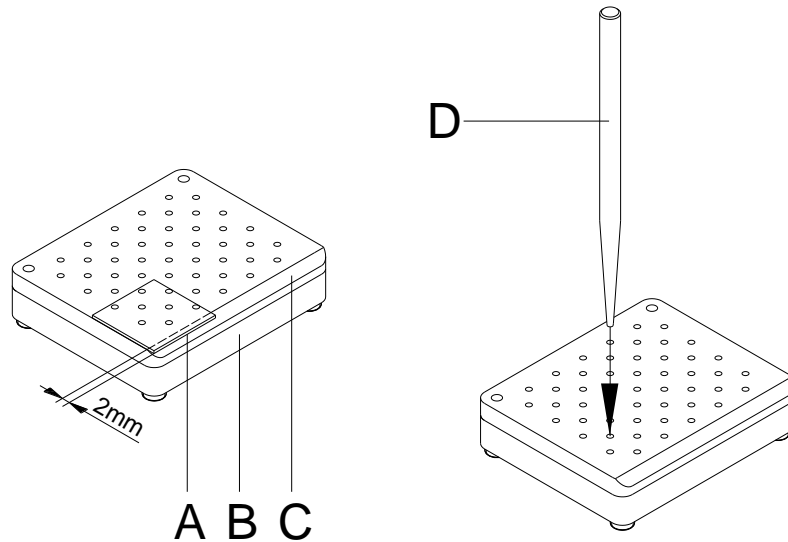

**Figure 12**

1. Attach the support plate (B) to the front plate (A) of the printing system using screws (C).
2. Attach hinges (E) of the applicator to the front plate (A) of the printing system using screws (F).
3. Connect the plug (H) of the applicator with the peripheral connection (I) of the printing system and secure with screws (D).
4. Pivot the applicator and secure with locking pins (G).

### 5.3 Piercing the Universal Tamp Pad

On the bottom of the pads there are holes for sucking and holding the labels by vacuum. When an universal tamp pad is delivered these holes are covered by the sliding foil and must be opened according to the label size. For that purpose a piercing pin is included in the contents of delivery.



**Figure 13**

1. Place a label (A) to be operated on the bottom side of the pad (B). Note the position of the slanted edge (C).
2. Align the label to the side edge in such a way that it reaches over the rear edge of the pad by 2 mm.
3. Open all the holes, which are certainly covered by the label. Open the holes completely by turning the piercing pin (D) inside the holes.



**CAUTION!**

Malfunctions by a too weak vacuum.

- ⇒ Do not open holes which are located less than 1 mm from a label edge.

## 5.4 Preparing for Using a Sprint-Mounted Tamp Pad



### NOTICE!

For using a spring-mounted universal tamp pad (90 x 120 mm) the fitting of the cylinder unit must be changed.

The cylinder unit (E) can be mounted on the bracket (A) in multiple different positions.

When the applicator is delivered, the cylinder unit (E) is mounted on the bracket (A) using the upper threaded hole. That position is suitable for the most pads.

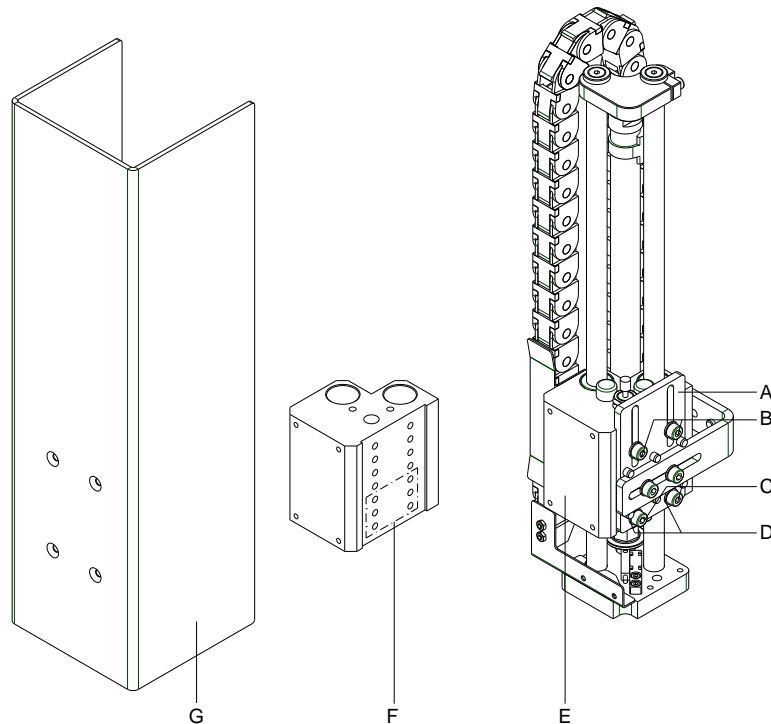
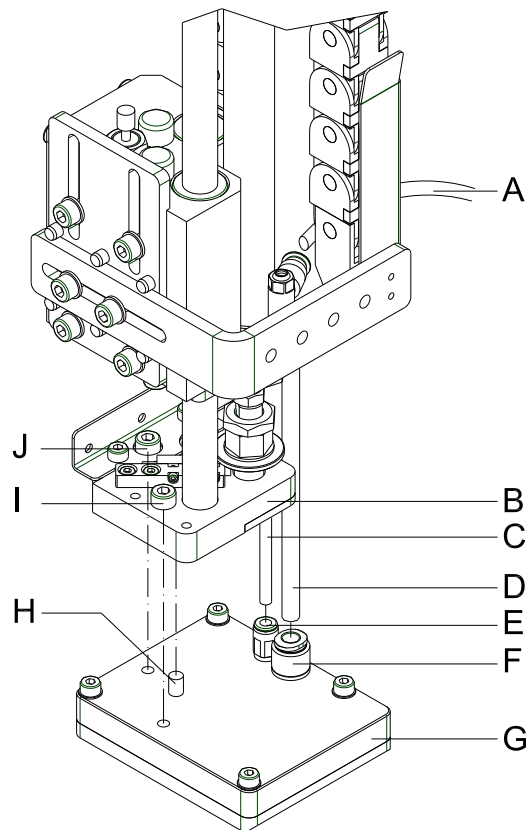

**Figure 14**

1. Remove cylinder cover (G).
2. Remove screws (B+C) and washers (D).
3. Push the cylinder unit (E) on the support plate (A) upwards.
4. Attach the cylinder unit (E) to the support plate (A) at the lower holes (F) using the screws (C) and washers (D).



## 5.5 Installing the Pad



**Figure 15**

1. Pull the tube (A) out of the push-in-fitting.
2. Insert the pin (H) on the pad (G) into the hole on the bottom side of the guiding plate (B).
3. Fix the pad (G) with the cylinder screws (I, J) at the pad holder (B) and make a rough adjustment of the pad to the dispenser edge of the printing module.
4. Insert the vacuum tube (C) and the blowing air tube (D) into the appropriate push-in-fittings (E, F) of the pad.
5. Insert the tube (A) into the connection of throttling back valve on the cylinder.



### CAUTION!

Danger of collision of the pad with other parts of the labelling system.

⇒ Before connecting the applicator to the compressed air supply please roughly align the pad in all directions..

## 5.6 Installation of Connections

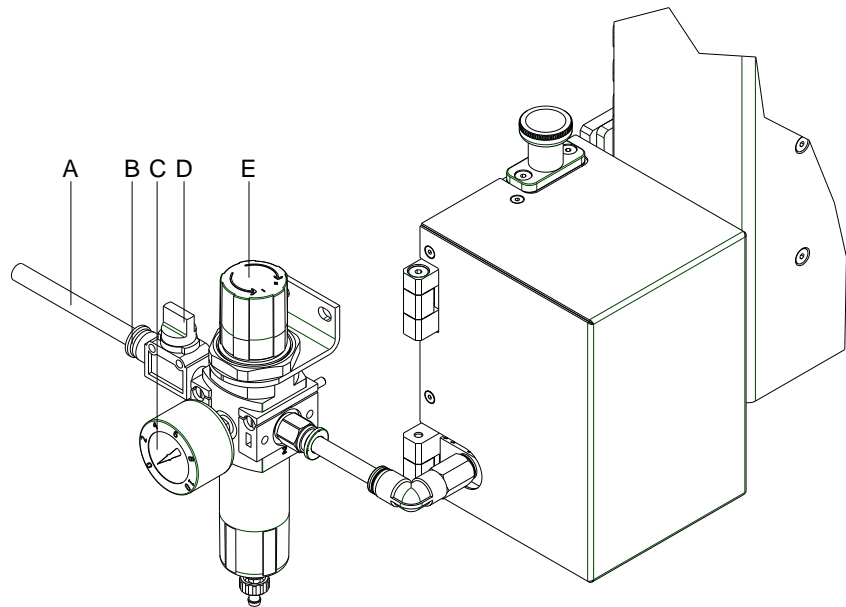

**Figure 16**

1. Prepare the power supply and interface ant the printing system (see operating manual of the printing system).
2. Close the shut-off valve (D / lever at the valve is turned across the air flow direction).
3. Connect the applicator to the compressed air supply.
4. The operating air pressure for the applicator is pre-adjusted to 0,5 MPa (5 bar). Check the pressure at the manometer (C) of the service unit. Correct the adjustment if necessary:
  - pull knurled knob (E) up.
  - turn knob to tune required operating pressure of 5 bar.
  - push knob down.
5. Open the shut-off valve (D / lever is turned in the air flow direction).
6. Switch on the printing system at the power switch.



### CAUTION!

The pad will immediately be moved in the starting position.  
 Danger of crushing to hand and fingers by the moving pad.

- ⇒ Do not reach into the zone of the moving pad.
- ⇒ Keep long hair, loose clothes and jewellery distant from the zone of the moving pad.
- ⇒ Danger of striking by the moving rods.  
 Do not reach or bend into the zone of the moving rods.

## 6 Options

### 6.1 Quick Apply

The optional "quick apply" function allows reduction of the impact pulse of the pneumatic cylinder.

"Quick apply" is an adjustable pneumatic absorption and/or brake by means of an additional pneumatic valve.

The cylinder is set to the maximum speed. The "quick apply" function decelerates the pad of the applicator just before the application surface of the product. In this way, cycle times are increased without damaging the product.



#### NOTICE!

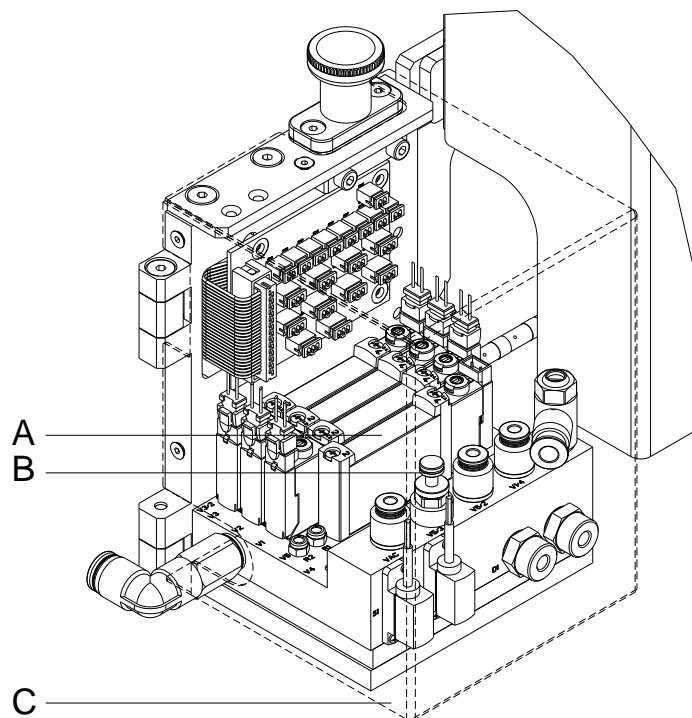

**Figure 17**

1. Unscrew and remove the protective cover (C) (see chapter 3.4, page 18).
2. Turn the adjusting screw (B) to set the absorption of solenoid valve (A).
3. Attach the protective cover.
4. In the "quick apply" menu of the printing system, set the desired delay in ms for valve activation.

## 6.2 Shock Absorber

The optional shock absorber allows reduction of the impact pulse of the pneumatic cylinder.

The additionally installed shock absorber absorbs the impact forces of the cylinder and ensures a soft limit position of the pad.

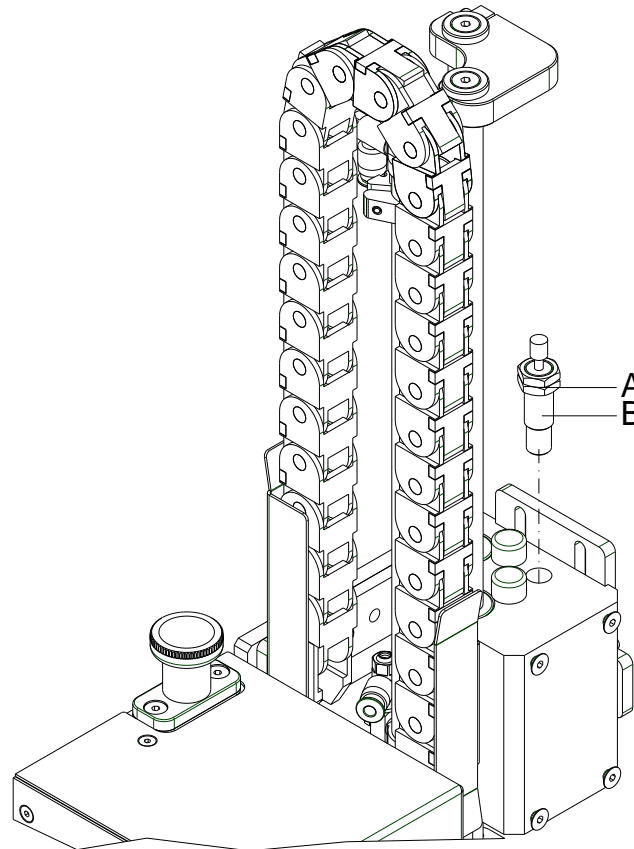
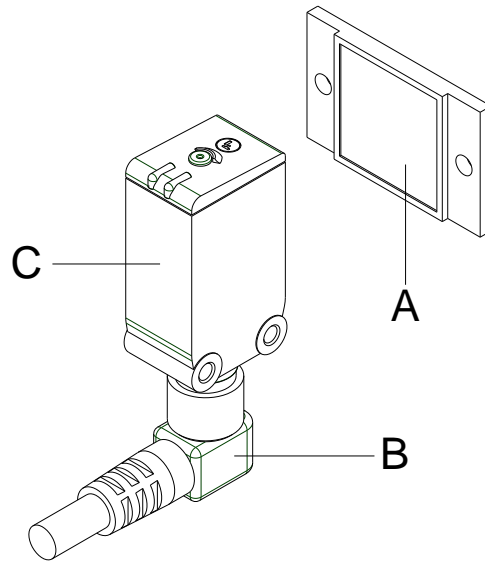

**Figure 18**

1. Move the shock absorber (B) to the desired height by screwing it in.
2. Secure the position of the shock absorber (B) against unintentional loosening using the counter nut (A).

### 6.3 Product Sensor

The "product sensor" option is used for optical, contact-free registration of products in order to obtain input signals for the printing system.



**Figure 19**

A = Reflector

B = Connecting line

C = Reflexion photocell



**NOTICE!**

When using reflection photocells you should observe that other light (e.g. working lamp) on the photocell is prevented.

1. Connect the connecting line (B) of the reflection photocell (C) to the I/O 24 interface.
2. Attach the reflector (A) at right angles with the reflection photocell (C).



## 7 Configuration

The label applicator can be operated in different ways. While the original process stays the same, the operation mode can be chosen within the function menu of the connected printing system.

The most important setting is the selection between the operating modes "stamp on", "blow on" and "roll on". Additionally the applicator has different application modes concerning the order of printing and applying within one labelling cycle.

	Stamp on	Roll on	Blow on
Print-Apply	✓	✓	✓
Apply-Print Waiting position up	✓	✓	✓
Apply-Print Waiting position down			✓

### 7.1 Configuration Parameter

Parameter	Meaning	Selection
Operating mode	Setting of operating mode Default: Stamp on	Stamp on, Blow on, Roll on
Mode	Setting of application mode Default: Print-apply	Print-apply Apply-print
Vacuum delay	Duration of switch-on delay Vacuum Default: 0 ms	0 ... 2500 ms in steps of 10 ms
Support delay On	Duration of switch-on delay for supporting air Default: 0 ms	0 ... 2500 ms in steps of 10 ms
Support delay Off	Duration of switch-off delay for supporting air Default: 500 ms	0 ... 2500 ms in steps of 10 ms
Pressure control	Function of compressed-air control Default: On	On Off
Vacuum control	Function of vacuum control Default: On	On Off
Pressure time	Duration of pressure time Default: 100 ms	0 ... 5000 ms in steps of 10 ms
Blow time	Duration of blow time Default: 100 ms	0 ... 2500 ms in steps of 10 ms

<b>Parameter</b>	<b>Meaning</b>	<b>Selection</b>
Waiting position	Waiting position of pad with dispensed label for "blow on + Apply-print" Default: Up	Up Down
Roll on time	Duration of roll on time Default: 0 ms	0 ... 5000 ms in steps of 10 ms
Cleaning time	Duration of cleaning time Default: 100 ms	0 ... 2500 ms ins steps of 10 ms
Timeout hub	Moving up/down of pad Default: 0 ms	0 ... 5000 ms in steps of 10 ms
Quick-Apply (option for APX 7000)	Duration of switch-on delay of the additional cylinder valve	0 ... 2500 ms in steps of 10 ms
Querachse (not available at APX 7000)	Setting, if a transversal movemen is to be effected before the downwards movement of the pad Default: Off	On Off
Labelling signal	Setting, if printing and labelling of the label is to be released separately Default: Off	Off Print position Labelling position
Test functions	Hub setting Test run of pad without label	





## 7.2 Settings in Printing System Function Menu

Switch on the printing system and the display shows the main menu.

Press key  to access the function menu.

Press key  as long as you arrive the *Label applicator* menu.

Press key  to select the menu.

Press key  to change to the next mode.

### Operating modes

#### Stamp on:

The label remains in a fixed position. The label is pressed directly onto the product.

#### Blow on:

The pad moves to a pre-adjusted position approximately 10 mm away from the product. The label is blown onto the product by an air jet stream. The print and apply cycle performs in a fixed position or in linear movement of the product.

#### Roll on:

The label is dispensed and moved until touching the roller of the roll on pad. In the labelling position, this roll is pressed onto the product. Then the label is applied and rolled on by the movement of product.

Press key  to arrive the next parameter.

### Mode

The applicator can be operated in two different ways concerning the order of printing and labelling within one labelling cycle (see chapter 8, page 39).

#### Print-Apply:

The print of a label is released by an external start signal. At the same time the vacuum on the pad as well as the supporting air from the blow tube are switched on. If the label is printed and picked up completely from tamp, the supporting air is switched off and the lift cylinder is controlled to move the pad down towards the labelling position. A sensor signals when the labelling position is reached.

Following, the vacuum is switched off and the label is transferred to the product. After applying the label, the lift cylinder is so controlled that the pad is again moved back to the starting position.

Now the labelling cycle is finished.

**Apply-Print:**

At the beginning of the cyclic operation 'Apply-Print' the first label is printed immediately and passed to the pad.

The pad with the printed label is in starting position and the vacuum at the pad is switched on.

At start of the cyclic operation when sending the start signal, the first label is already on the pad. The following process is similar to the mode 'print-apply' but at the end of the cycle the next label is printed and picked up by the pad.

Now the labelling cycle is finished.

Press key  to arrive the next parameter.

**Vacuum delay**

The vacuum is connected not immediately with print start, but only if the label were put forward a certain time. This delay causes that the label runs more easily under the pad as it is not sucked and in this way braked.

Value range: 0 ... 2500 ms

Step size: 10 ms

Default: 0 ms

Press key  to arrive the next parameter.

**Support delay On**

The supporting air from the blow tube is not immediately switched on at print start but only if the label has covered a distance.

This delay helps to prevent a turning or swinging at the front of the label and consequently avoids faults when the label is being picked up from printing system.

Value range: 0 ... 2500 ms

Step size: 0 ms

Default: 0 ms

Press key  to arrive the next parameter.

**Support delay Off**

Delayed to the process of the label being picked up, the supporting air is switched off.

In many cases, after being picked up by the pad the label edge may still stick on the liner. This may affect the accuracy of the label positioning or even cause faults in the labelling. Therefore, switching off the air blow delayed can be useful to separate the label from liner and neatly place the label on the surface of pad.

Value range: 0 ... 2500 ms

Step size: 10 ms

Default: 500 ms

Press key  to arrive the next parameter.

### Pressure control

With activated compressed air control, with help from a compressed air sensor it is checked at each labelling cycle if the compressed air fits with the valve block. If no compressed air is presented, the labelling cycle is stopped and the error message 'compressed air' is displayed.

If the parameter 'pressure control' is set to Off, the error treatment as described above will not be effected. This can be especially helpful at initiation of the labelling system.

For standard operation, set the parameter to On.

Press key  to arrive the next parameter.

### Vacuum control

The label transfer from printing system to applicator is controlled by a vacuum sensor. If the transfer of label fails, the sucking holes on the pad will not be covered by the label and therefore no vacuum can originate on the pad. Afterwards an error message appears and the label strip will be fed back.

If the parameter 'vacuum control' is set to Off, the error treatment as described above will not be effected. This can be especially helpful during adjustments, because the immediate backfeed will be cancelled and therefore it is easier to check the reasons for the faulty transfer.

For standard operation, set the parameter to On.

Press key  to arrive the next parameter.

### Pressure time

This parameter is only active if the operating mode "stamp on" is selected. The time period can be adjusted while the pad is kept in the labelling position for applying the label onto the goods.

Press key  to arrive the next parameter.

### Blow time

This parameter is only active if the operating mode "blow on" is selected. The time period can be adjusted, while the blowing air is switched on for transferring the label onto product.

Value range: 0 to 2500 ms

Step size: 10 ms

Default: 100 ms

Press key  to arrive the next parameter.

### Waiting position



#### NOTICE

This parameter is only active if the operating mode "blow on" and mode 'apply-print' are selected.





#### Waiting position up:

In cyclic mode the pad with the printed label waits in the labelling position near the dispense edge of printing system for the external start signal.

#### Waiting position down:

In cyclic mode the printed label is transported to the labelling position at the end of a cycle.

So the next cycle begin with blowing up the label.

- Press key  to arrive the next parameter.
- Roll on time**
- This parameter is only active if the operating mode "blow on" is selected. The time period can be adjusted while the roll on pad is stopped in labelling position.
- Value range: 0 ... 5000 ms  
Step size: 10 ms  
Default: 0 ms
- Press key  to arrive the next parameter.
- Cleaning time**
- This parameter is only active if the operating mode "blow on" and "roll on" are selected. The time period can be adjusted for the cleaning period of pad after application procedure.
- Value range: 0 ... 2500 ms  
Step size: 10 ms  
Default: 100 ms (No error message is triggered and the printing system waits until the pad has achieved the corresponding limit position)
- Press key  to arrive the next parameter.
- Stroke timeout**
- Moving up and down of pad.  
If the pad does not reach the corresponding final position within the set time, then an error message appears ('final position above' at moving up and/or 'final position below' at moving down).
- Value range: 0 ... 5000 ms  
Step size: 10 ms  
Default: 0 ms
- Press key  to arrive the next parameter.
- Quick-Apply delay**
- Only with available option quick-apply:**  
With this function, the travel speed of the cylinder may be reduced before it hits the product. The time until the delay commences may be set. The exhaust throttle (bottom) on the cylinder must be opened completely for this (see page 27).
- Value range: 0 ... 2500 ms  
Step size: 10 ms  
Default: 0 ms
- Press key  to arrive the next parameter.
- Transverse axis**
- Only with available option transverse axis:**  
This function allows you to set if the pad makes a transversal movement before the upwards movement, and/or accordingly after the upwards movement back into the print position.  
If the parameter 'transverse axis' is set to On, in each case a transverse movement takes place. At setting Off, no transversal movement takes place and the application procedure begins in the print position.

**Labelling signal**

Press key  to arrive the next parameter.

If printing and applying of the label are to separately released, a separate signal for applying the label can be activated (port 4, start applying).

**Off:**

No labelling signal is used, i.e. after printing the label and takeover onto the pad, the applying procedure begins immediately.

**Print position:**

After printing the label and takeover onto the pad, the printer waits in print position for the labelling signal.

**Labelling position:**

After printing the label and takeover onto the pad, the pad makes a transversal movement into the labelling position. There the printer waits for the labelling signal. With applicators without transversal axis, this setting is identical with the setting 'print position'.

Press key  to arrive the next parameter.





**Test functions****Stroke adjust**

The arrester can be adjusted and the stroke speed can be set. The pad makes a stroke movement and return again to the basic position after reaching the lower end position.

Press key  to start the stroke movement.

**Input/Output**

Press key  to arrive the next parameter.

This menu serves for the applicator setup as well as for error tracing. Input signals of the applicator can be monitored and output signals can be set or reset separately. With keys  and  the corresponding output for setting and/or resetting the output signals can be selected. With keys  and  the corresponding output can be set or reset.

**Input signals**

- I<sub>1</sub> = Pre-dispense key
  - 1 = key pressed
  - 0 = key not pressed
- I<sub>2</sub> = Final position up
  - 1 = pad in final position up
  - 0 = pad not in final position up
- I<sub>3</sub> = Final position down
  - 1 = pad in final position down
  - 0 = pad not in final position down
- I<sub>4</sub> = Compressed air
  - 1 = compressed air available
  - 0 = no compressed air available
- I<sub>5</sub> = Vacuum
  - 1 = vacuum at pad available
  - 0 = no vacuum at pad available
- I<sub>6</sub> = Final position right
  - 1 = pad in final position right
  - 0 = pad not in final position right
- I<sub>7</sub> = Final position left
  - 1 = pad in final position left
  - 0 = pad not in final position left

**Output signal**

- O<sub>1</sub> = Move pad downwards
  - 1 = On / 0 = Off
- O<sub>2</sub> = Move pad upwards
  - 1 = On / 0 = Off
- O<sub>3</sub> = Transverse right
  - 1 = On / 0 = Off
- O<sub>4</sub> = Transverse left
  - 1 = On / 0 = Off
- O<sub>5</sub> = Blowing air
  - 1 = On / 0 = Off
- O<sub>6</sub> = Supporting air
  - 1 = On / 0 = Off
- O<sub>7</sub> = Vacuum
  - 1 = On / 0 = Off

## 8 Signal Diagrams

### 8.1 Print – Apply (w/o transverse axis)

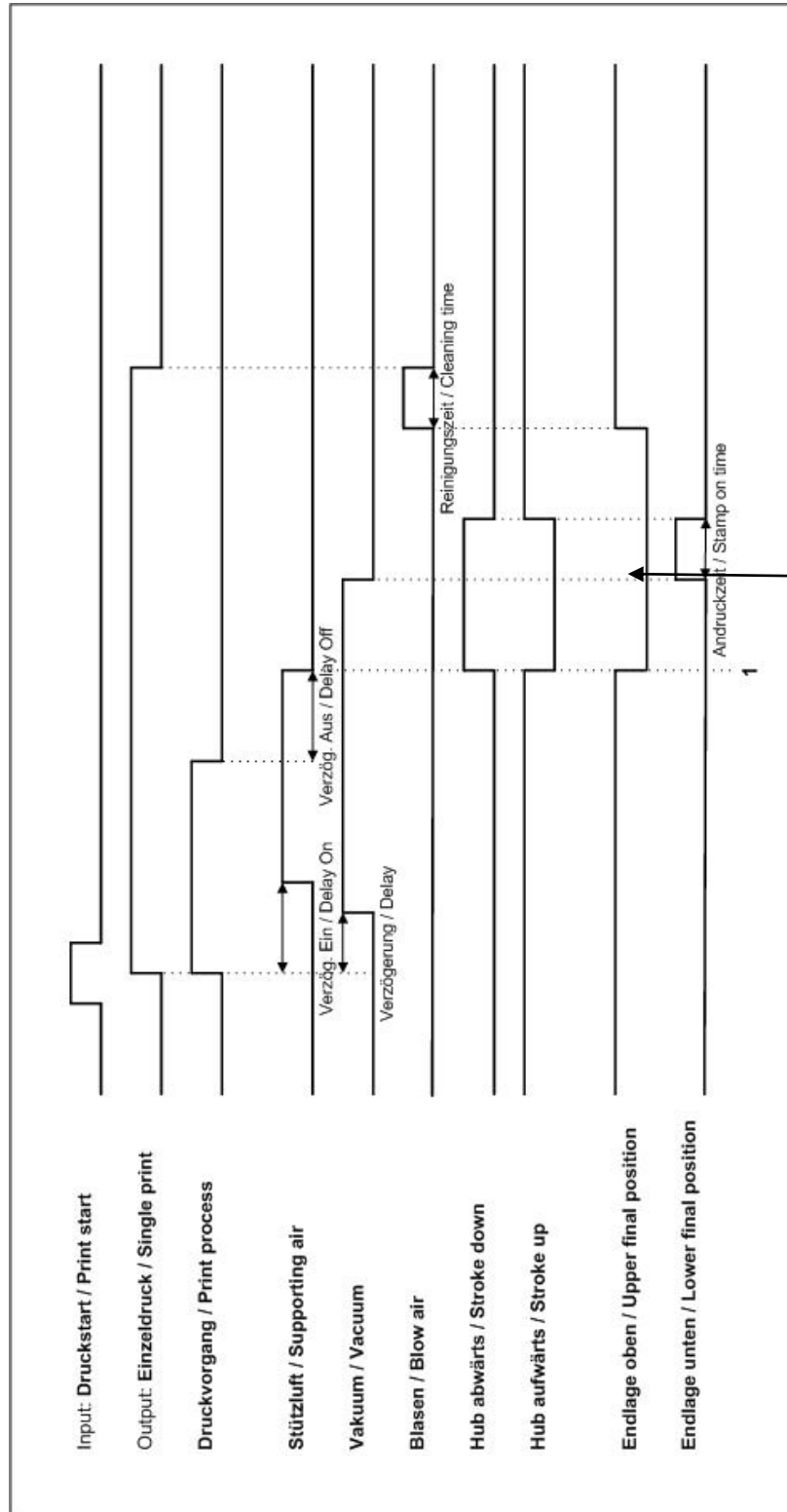

At labelling signal = print position/labelling position, the printer waits here in the print position (identical with the labelling position) for the signal 'applying start' before the label is applied.

Figure 20

### 8.2 Apply – Print (w/o transverse axis)

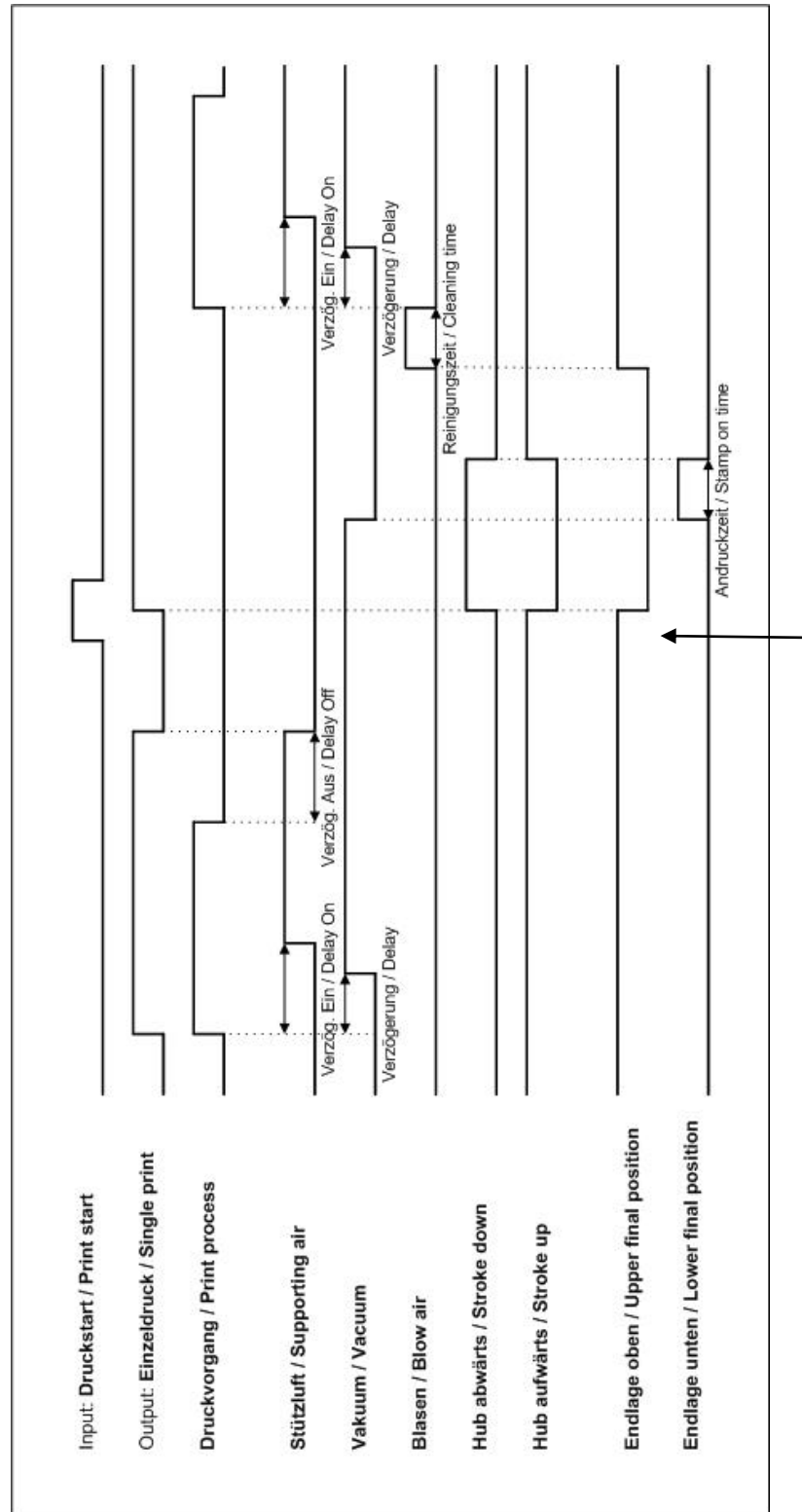

At labelling signal = print position/labelling position, the printer waits here in the print position (identical with the labelling position) for the signal 'applying start' before the label is applied.

Figure 21



## 9 Mechanical Adjustments



### NOTICE!

Before starting with the mechanical adjustments, remove the plexiglass cover (A) by loosening 4 screws.

Perform the mechanical adjustments in two steps

- ⇒ Roughly align the pad in all directions to avoid collisions of the pad with other parts when switching on the compressed air.
- ⇒ Perform the fine adjustment with compressed air switched on to optimize the labelling process.

### 9.1 Aligning the Pad

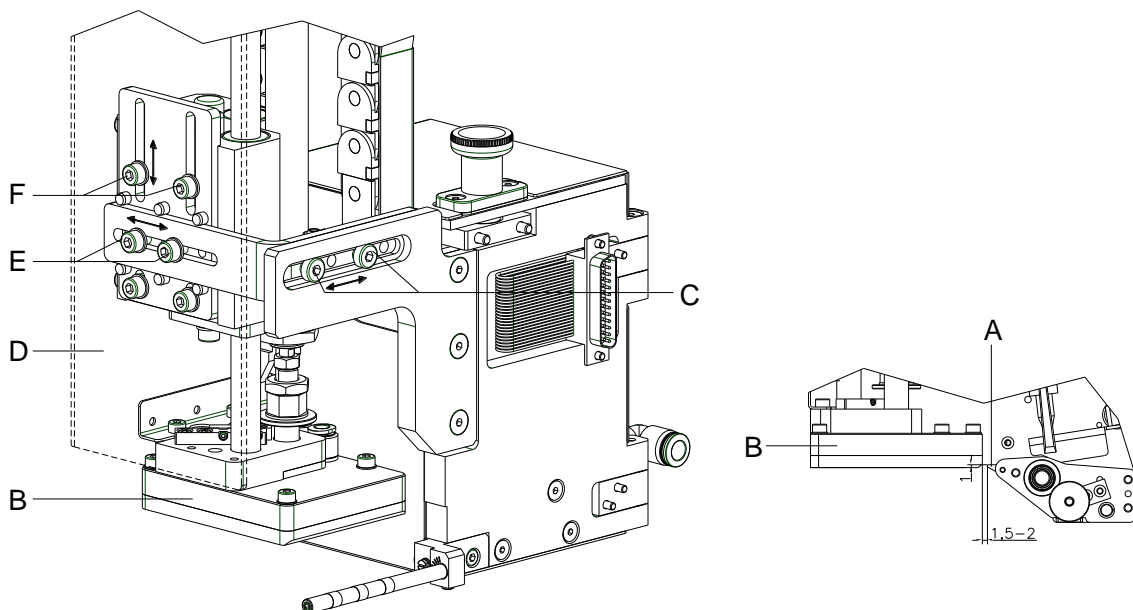

Figure 22

#### Adjustment in print direction

1. Loosen screw (E).
2. Shift the cylinder unit including the pad (B) inside the elongated hole in such a way, that the distance between the pad and the dispense edge (A) is about 2 mm.
3. Tighten screw (E).

#### Height adjustment

1. Loosen screw (F).
2. Shift the cylinder including the pad (B) inside the elongated hole in such a way that the lower rear edge of the pad (4) is located about 1 mm below the dispense edge (A) of the printing system.
3. Tighten screw (F).

**Side adjustment**

1. Loosen screw (C).
2. Shift the cylinder unit including the pad (B) inside the elongated hole in such a way, that the dispensed label is aligned centrally to the pad respectively to the open holes in an universal pad.
3. Tighten screw (C).

**NOTICE!**

Check the adjustment with compressed air switched on.

## 9.2 Adjusting the Parallelism between Pad and Dispense Edge

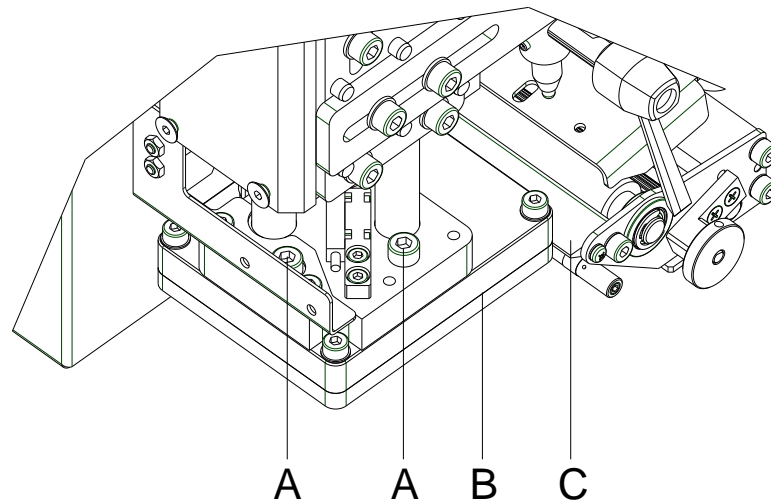

**Figure 23**

1. Loosen screw (A).
2. Adjust the parallelism between the rear edge of the pad (B) and the dispense edge (C) by turning the pad.
3. Tighten screw (A).

## 9.3 Opening the Holes on the Blow Tube

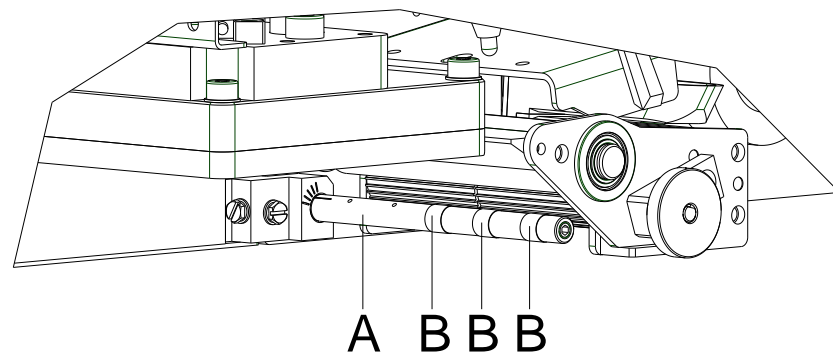

**Figure 24**

1. The blow tube (A) has holes for the supporting air in regular distances of 14 mm.
2. When the applicator is delivered only the two inner holes are open. The other holes are closed by plastic rings (B).
3. To adjust the supporting air to the label width, the plastic rings (B) can be removed from the holes.
4. Open all holes, which affect certainly the area of the label.

## 9.4 Aligning the Blow Tube

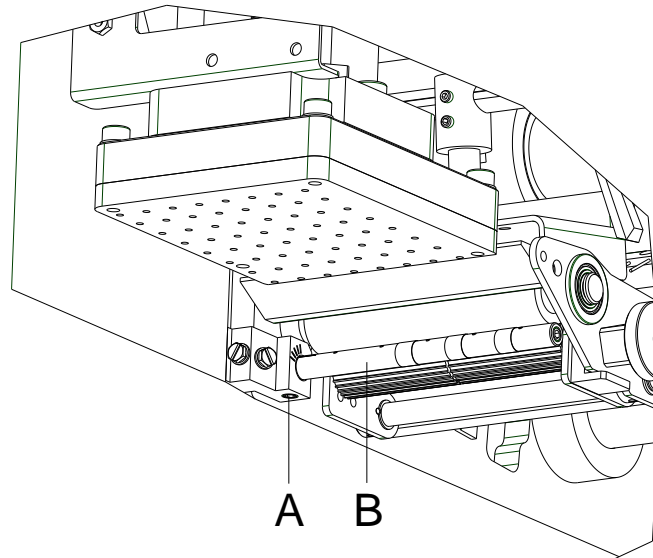

**Figure 25**

The blow tube (B) for the supporting air can be rotated around its axis. That way the direction of the supporting air can be optimized.

1. Loosen screw (A).
2. Turn the blow tube (B) in that direction that the air current supports the sucking of the label by the pad.

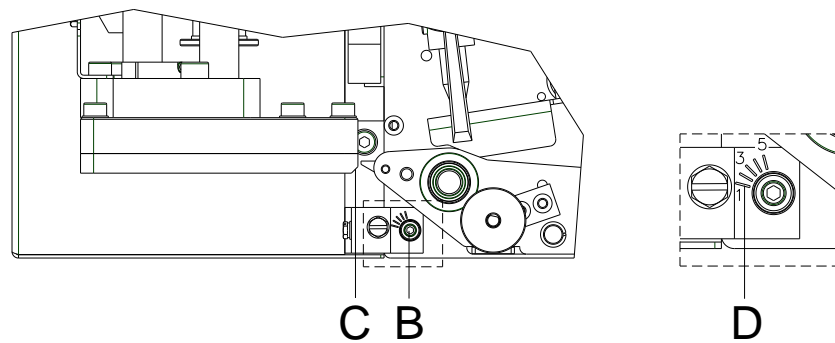

**Figure 26**

3. For small labels direct the air current to the dispense edge (C) of the printing system (setting 3 or 4 at the scale(D)).
4. For larger labels direct the air current away from the dispense edge (C / setting 1).
5. Tighten screw (A).

## 9.5 Adjusting the Stopper



### NOTICE!

The description for adjusting the stopper is only relevant for the "blow on" operating mode.

The stopper is not required in the operating modes "stamp on" and "roll on". It may not limit the pad movement (see next page).

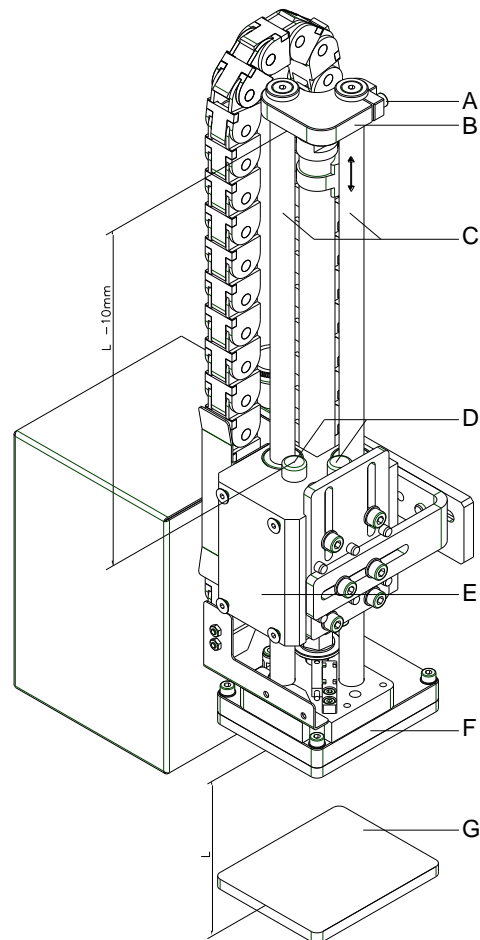

Figure 27



### CAUTION!

Danger of injury by inadvertent move out of the cylinder.

⇒ Switch off the printing system and close the shutoff valve for the compressed air at the service unit.

**NOTICE!**

When delivered, a stopper (B) is attached to the guiding rods (C).

**Operating mode  
Blow on**

In the "*blow on*" operating mode, the stopper is used to limit the downward movement of the pad in order to set a fixed labelling position.

1. Place sample (G) of the product to be labelled at the labelling position.
2. Measure the distance between the pad bottom edge (F) and the product top edge (G) (distance = L).
3. Loosen the cylinder screw (A) in the stopper (B).
4. Push the stopper (B) against the housing (E) and set a distance between the underside of the stopper (B) and the rubber buffer (D) of L-10 mm.
5. Push the stopper (B) against the housing (E) and tighten the cylinder screw (A).

**Operating modes  
Stamp on and  
Roll on**

The stopper is not required in the operating modes "*stamp on*" and "*roll on*". The stopper may not limit the pad movement.

1. Loosen the screw (A) in the stopper (B).
2. Push the stopper (B) upwards as far as possible and tighten the screw (A).

## 10 Pneumatic Adjustments

### 10.1 Control Valves

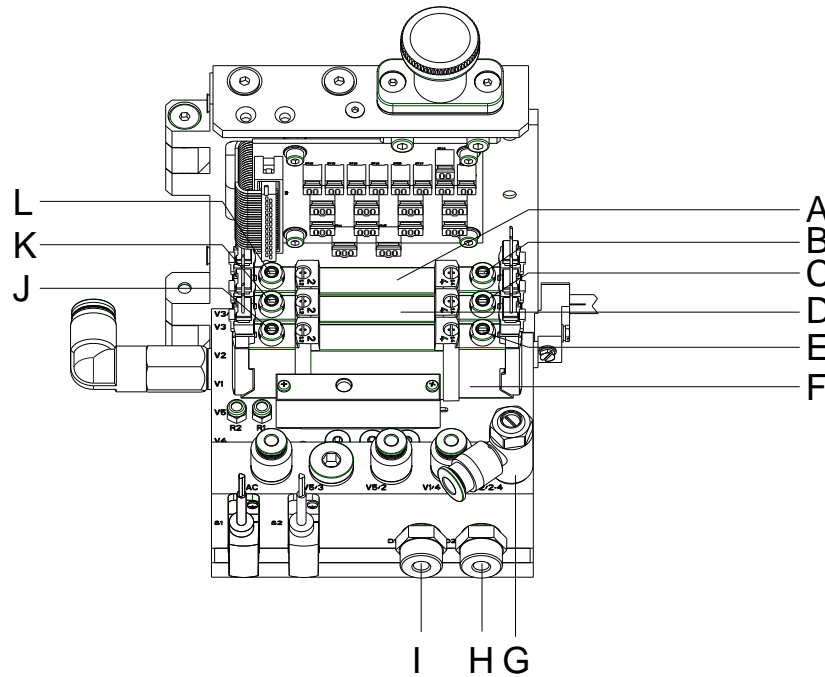

Figure 28

For adjustments of certain applicator functions it is possible to release the control valves in the pneumatic system.

- ⇒ Loosen screws and remove cover of pneumatic unit.
- ⇒ The compressed air control valves can be controlled manually with integrated switch.

#### 3-way valve (F) to control the lift cylinder

If the printing system is switched on the valve will be controlled by electronics and the tamp will hold in the upper end position (home position). If the valve is switched the tamp will move in the lower end position (labelling position).

In normal labelling operation the movement back in the upper end position will start by a signal from the labelling sensor.



#### NOTICE!

The switching by hand of this valve has only a result in case of a switched off printing system.

Switching the valve by hand over switch (E) the tamp will move down up to the lowest possible position because no control is made by the sensor.

Switching the valve by hand over switch (J) the tamp will move up.

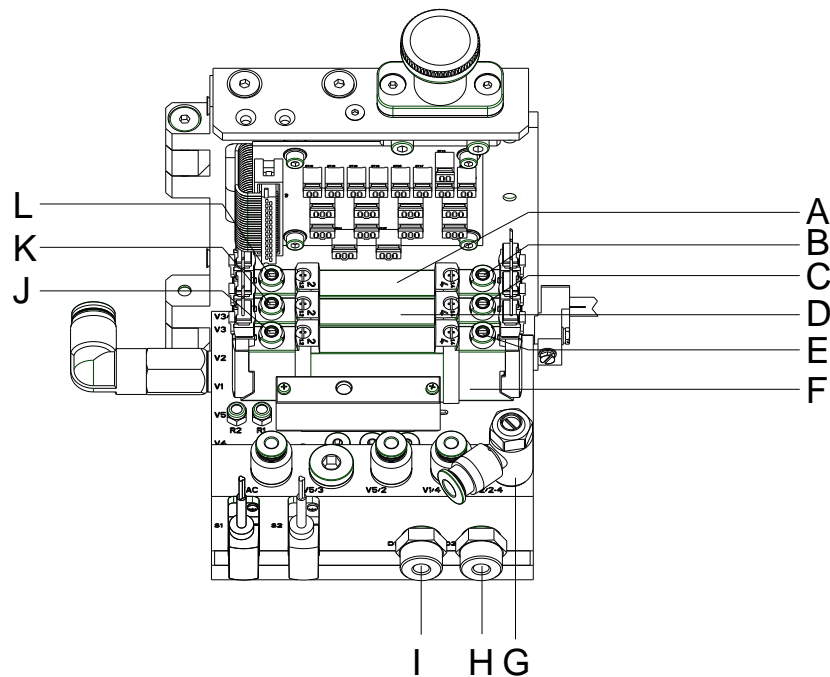

**Figure 29**

**Double 2-way valve (D)  
for blow air**

In the operation mode "blow on" the label will blow up to the product.

In the operating modes "stamp on" and "roll on" the blow air is switched on for a short time after each application to avoid contaminations within the vacuum channels.

For all described functions both valves will be controlled parallel.

By pressing the switch (C or K), the blowing air is only switched on by one of both internal valves. The blowing air can be set with a throttling back valve (G, see chapter 10.3).

**Double 2-way valve (A)  
for vacuum /  
supporting air**

The two internal valves serve the vacuum nozzle for connecting an in this way for creating the negative pressure at the tamp and independent of this for connecting the support air at the blow tube for the label transfer.

By pressing switch (B) the vacuum is switched on. The vacuum can be set with the throttling back valve (H, see chapter 10.3).

By pressing switch (L) the supporting air is switched on. The supporting air can be set with the throttling back valve (I, see chapter 10.3).



## 10.2 Adjusting the Pad Movement Speed

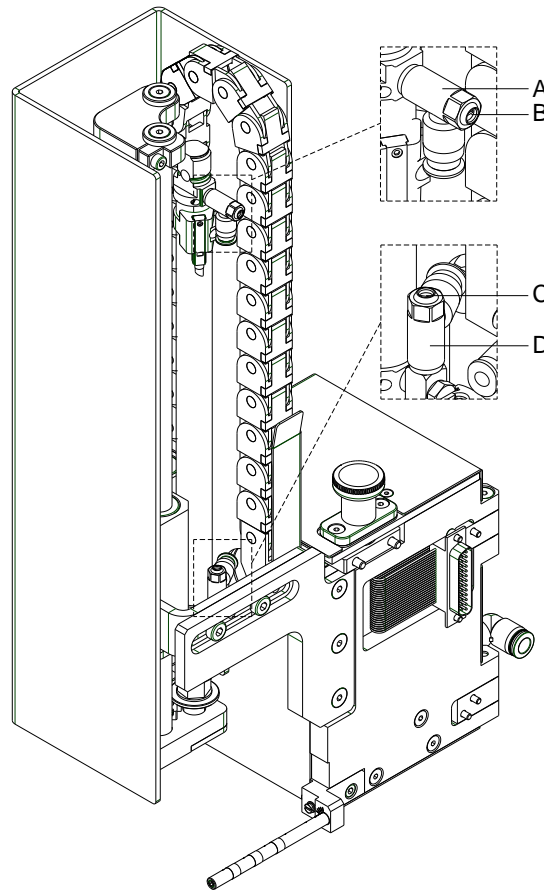

**Figure 30**

The adjustment of pad movement speed can be regulated with two throttle valves (A, D).

- ⇒ Adjust the pad movement speed as necessary.
- ⇒ To increase the downward speed turn the screw (C) at the lower valve (D) anticlockwise.
- ⇒ To increase the upward speed turn the screw (B) at the upper valve (A) anticlockwise.



### NOTICE!

The application pressure of the pad is mainly dependent on the downward speed of the pad.

- ⇒ To reduce the application pressure turn screw (C) in clockwise direction.



### CAUTION!

A too high decrease of the downward speed leads to an error message (Error 101 - Lower position).

- ⇒ The downward movement may not need more time as specified in the menu *Timeout Hub* (see page 36).

### 10.3 Adjusting Vacuum and Supporting Air

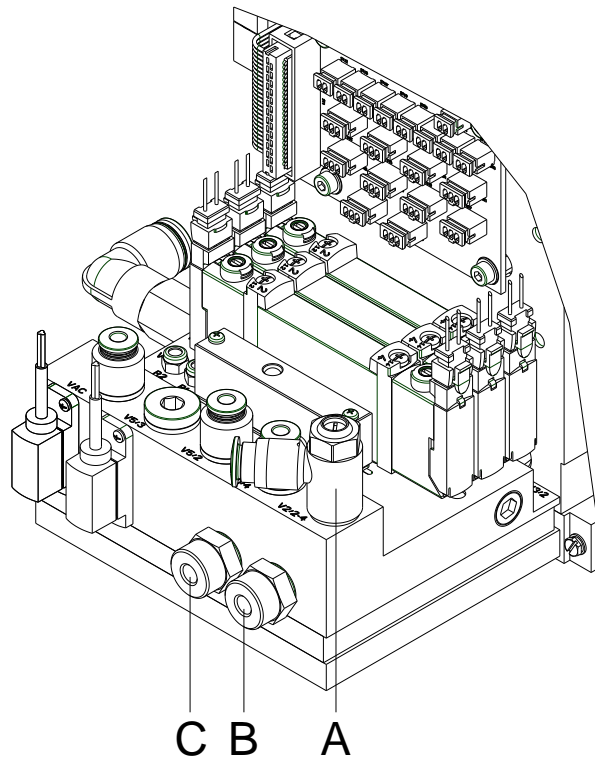

**Figure 31**

#### Adjusting the supporting air

With the valve (C) the supporting air for blowing the label to the pad can be varied.

- ⇒ Adjust the supporting air in such way that the label is blown on the pad without swirling.
- ⇒ To increase the supporting air turn the screw at the valve (C) anticlockwise.
- ⇒ If necessary adjust the direction of the air current (see chapter Aligning the Blow Tube, Seite 44).

#### Adjusting the vacuum



#### NOTICE!

With the vacuum setting the final position of the label on the pad can be adjusted. If the vacuum is too high the label feeding may early be stopped.

With the valve (B) the vacuum for sucking the label to the pad can be varied.

- ⇒ Adjust the vacuum in such way that the label is correctly sucked.
- ⇒ To increase the vacuum turn the screw at the valve (B) anticlockwise.

**Adjusting the blowing air**

With the valve (A) the blowing air for blowing off the label from pad can be varied.

- ⇒ Adjust the blowing air in such way that the label is safely blown off and adheres to the product.
- ⇒ To increase the blowing air turn the screw at the valve (A) anticlockwise.



## 11 Operation

### 11.1 Loading Labels and Transfer Ribbon



#### NOTICE!

In dispensing mode the labels are removed after printing, and only the liner is wound up internally.  
For detailed information about inserting the material please read the operating manual of the printing system.

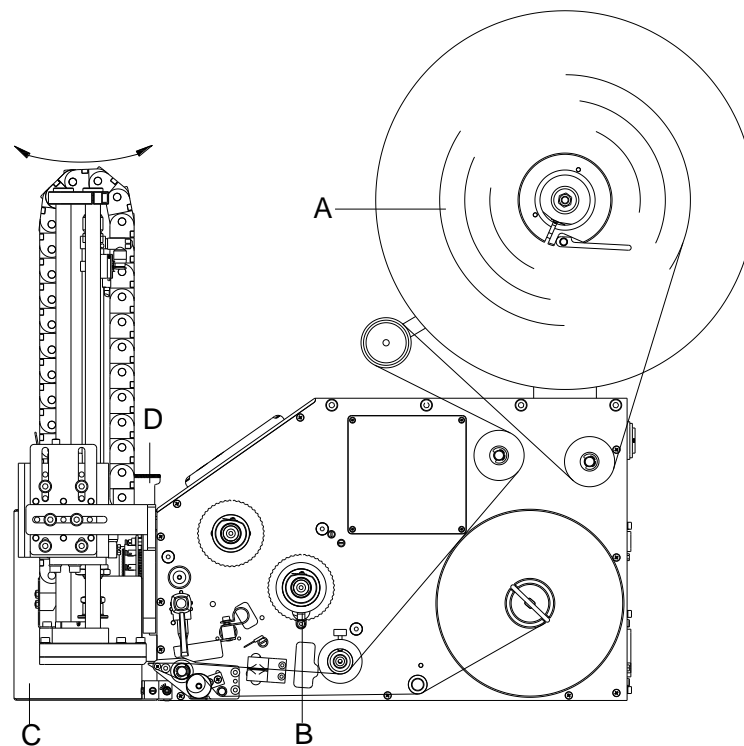

Figure 32



#### NOTICE!

For better accessibility, the applicator must be pivoted before inserting the labels and the transfer ribbon.

1. Pull the locking pin (D) upwards and rotate it by 90°.
2. Insert the transfer ribbon (B) in the printing system.
3. Insert the label material (A) in the printing system.
4. Close the applicator.



#### CAUTION!

Collision between the pad and the locking system during the labelling procedure.

⇒ Swivel the locking system on the rewind assistant roller.

## 11.2 Setting the Dispenser Moden



### NOTICE!

To operate the printing system in dispenser mode a print order must be started and the printing system is to be in 'waiting' mode.

Switch on the printing system and the display shows the main menu.

Press key to access the function menu.

Press key as long as you arrive the *Dispenser I/O* menu.

Press key to select the menu.

In the upper line of display, the operating mode can be selected.

In the line below, the dispenser I/O offset (approx. 18 mm) can be set.

Press key to change to the next operating mode.

### Operating modes

#### Off:

It is printed without the labels are dispensed.

#### I/O static:

The input signal evaluated, i.e. it is printed as long as the signal exists. The number of labels which was entered at the print start is printed.

The set dispenser offset is not taken into consideration.

#### I/O static continuous:

For description of this operating mode, see I/O static.

Continuous means that it is printed as long as new data is transferred via interface

The set dispenser offset is not taken into consideration.

#### I/O dynamic:

The external signal is evaluated dynamically, i.e. is the printing system in 'waiting' mode a single label is printed at each signal changing.

After the print the set dispenser offset is executed, i.e. a backfeed is effected.

#### I/O dynamic continuous:

For description of this operating mode, see I/O dynamic.

Continuous means that it is printed as long as new data is transferred via interface.

#### Photocell:

The printing system is controlled via photocell. The printing system prints automatically a label if the user takes away the label at the dispensing ledge. The print order is finished when the target number of labels is reached.

#### Photocell continuous:

For description of this operating mode, see Photocell.

Continuous means that it is printed as long as new data is transferred via interface.

### 11.3 Standard Operation

1. Check all external connections (see chapter 5.6, page 26).
2. Load the transfer ribbon and the label material (see chapter 11.1, page 53).

**NOTICE!**

Ensure that the locking system (4, Figure 32) is closed.

3. Open the shutoff valve.

**CAUTION!**

If the pad is covered the vacuum sensor may be calibrated faultily.

⇒ Before switching on the printing system-applicator system ensure that the pad is not covered.

4. Switch on the printing system.

**CAUTION!**

The pad will immediately be moved in the starting position.

⇒ Do not reach into the zone of the moving pad.

⇒ Keep long hair, loose clothes and jewellery distant.

⇒ Do not reach or bend into the zone of the moving rods.

5. Press the key  at the printing system.

A synchronization feed is released. The processed labels have to be removed manually. After a few seconds the printing system carries out a short backfeed to position the front edge of the next label at the printing line.

**NOTICE!**

This synchronizing also has to be carried out when the print job has been interrupted with the key .

Synchronizing is not necessary when the printhead was not lifted between print jobs. This also applies if the printing system was powered off between print jobs.

6. Start a print job.





## 12 Applicator Interface

Valves may be controlled and limit position sensors may be prompted via different control inputs and outputs.

The control inputs and outputs are made available via a D-sub bushing (25 pins, female) on the front plate of the printing system and are NOT GALVANICALLY ISOLATED.

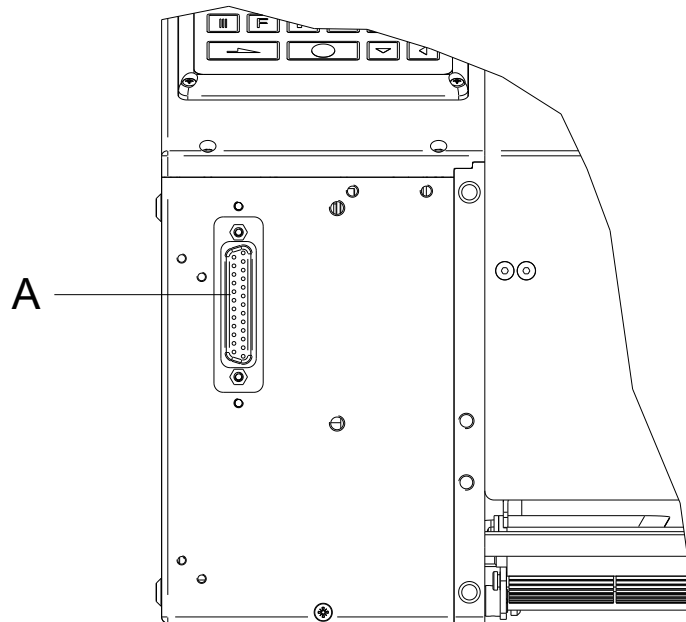

Figure 33

### 12.1 Printer internal circuitry

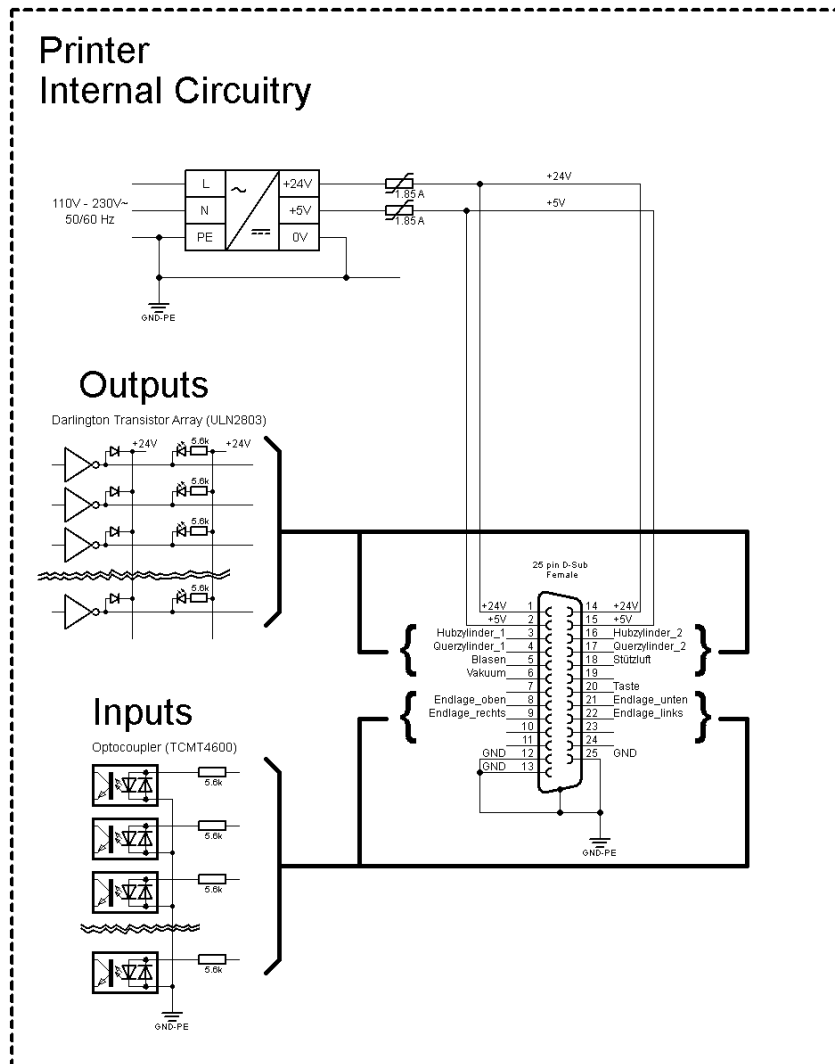

Figure 34

## 12.2 Pin assignment D-Sub bushing

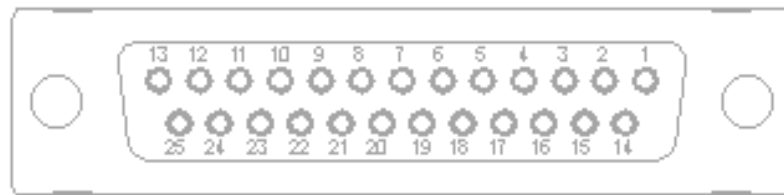

Figure 35

### Signal assignment

Pin	Signal	Pin	Signal	Description / Function
1	24V	14	24V	24 Volt DC output for external use max 1 A.
2	5V	15	5V	5 Volt DC output for external use max 1 A.
3	Stroke cylinder 1	16	Stroke cylinder 2	Outputs (open Collector) 24 V / 0,1 A
4	Lateral cylinder 1*	17	Lateral cylinder 2*	
5	Blow on	18	Supporting air	
6	Vacuum	19		
7		20	Switch	Digital inputs 24 V
8	Top end position	21	Bottom end position	
9	Right end position	22	Left end position	
10		23		
11		24		
12	GND	25	GND	GND-PE
13	GND			

\* Option, on demand only

**Technical data**

<b>Connection plug</b>	
Type	D-Sub connector 25 pin / connector
Producer/distributor	MPE Garry / Schukat
Order no.	LPBL25RZM
Output tensions (connected with GND-PE)	
+ 24 V / 1 A	Fuse: Polyswitch / 30 V / 1.85 A
+ 5 V / 1 A	Fuse: Polyswitch / 30 V / 1.85 A
Digital outputs	
Driver	ULN2803A (open Collector)
Tension	24 VDC
Current max	-0,1A
Impedance	Pull up 5,6 kΩ
Digital inputs	
Optocoupler	TCMT4600, CTR 80% - 300%
Tension	24 VDC
Impedance	5,6 kΩ
Analogue inputs (optional, on demand only)	
OP	LMV393
Tension	0..5 VDC
Impedance	>100 kΩ

### 12.3 Examples

#### Example 1

Device connection to a machine with S7-300 SPS.

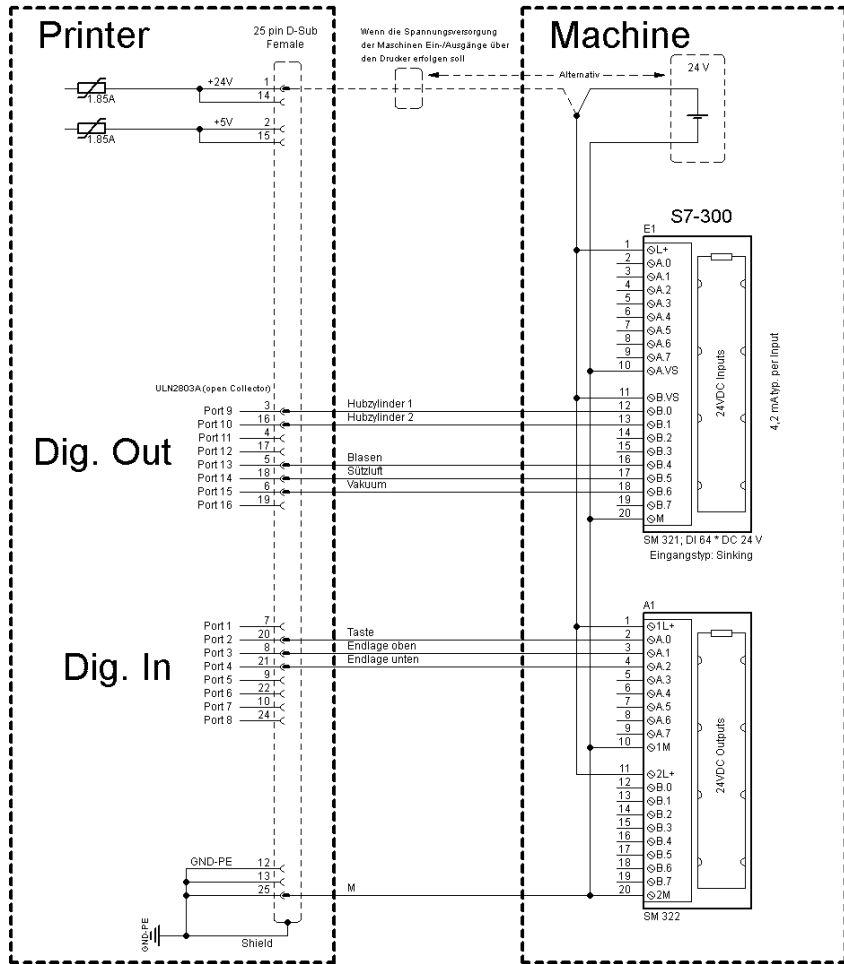
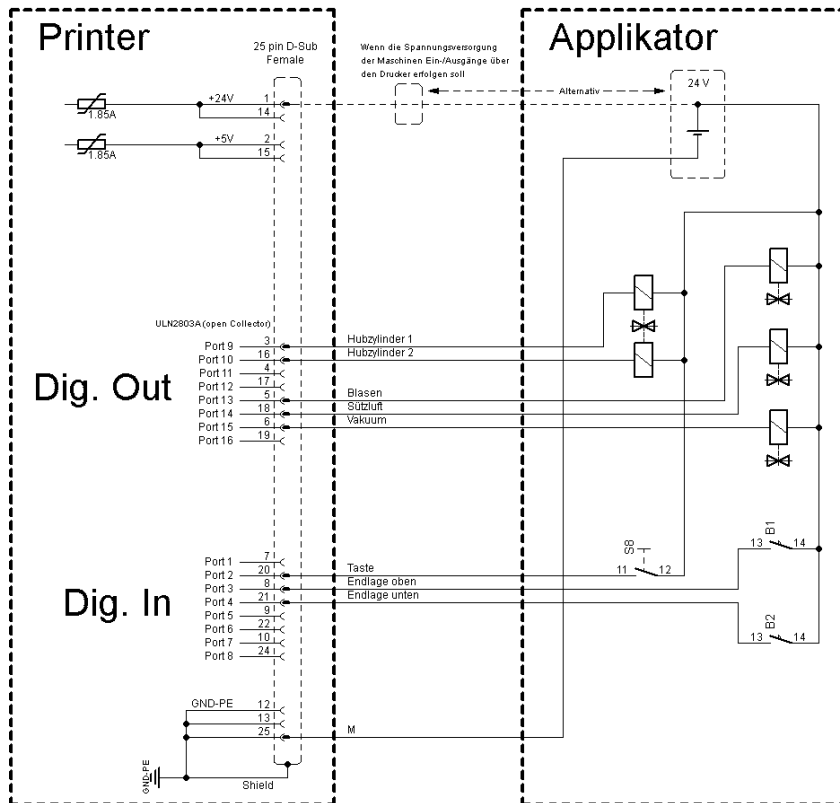

Figure 36

**Example 2**

Device connection to an applicator.



**Figure 37**

**12.4 Precautions**

When connecting a reed contact with a control input, the contact must have a switching capacity of min. 1 A in order to prevent the contact from sticking due to the inrush current. As an alternative, a suitable resistor can be connected in series.

If one of the printing system's internal voltages '+5 VDC EXT' or '+24 VDC EXT' is used, an external fuse e.g. 0.5 AF, should be additionally installed to protect the printing system electronics.

In the event of an inductive load, an antiparallel connected diode, for instance, must be used to discharge the induction energy.





In order to minimise the influence of leakage currents at control outputs, a resistor must, depending on what is connected, be installed in parallel with the load.

In order to avoid any damages to the printing system, the max. output currents must not be exceeded or outputs shorted.

## 13 Error Messages

### 13.1 Error Messages of the Printing System

In case an error occurred the printing system stops and the print order is interrupted. Information to causes and remedies of printing system errors e.g. *no label found* are to be taken from the printing system manual.

1. Clear the error.
2. Press the key  to synchronize the label feed.
3. Remove the peeled labels manually.
4. Press the key  to quit the error state.
5. Press the key  to continue the print order or press key  to cancel the print order.

### 13.2 Error Messages of the Applicator

Error message	Cause	Remedy
Upper position	The upper position (start position) was not reached.	Check final position switch for start position and compressed-air supply. Adjust stroke timeout.
Lower position	The lower position (labelling position) was not reached.	Check final position switch for labelling position and compressed-air supply. Adjust stroke timeout.
Empty vacuum plate	Sensor does not recognize a label at the vacuum plate.	Check if all holes of the pad plate are covered from the label. Check compressed-air supply. Check if the switching threshold of the vacuum sensor is correctly adjusted (see chapter 13.3, page 62).
Compressed air	No compressed air is available.	Check compressed air supply. Check if the switching threshold of the pressure sensor is correctly adjusted (see chapter 13.3, page 62).
Print position	At print start the pad is not in printing position (upper pad position).	Check the correct function and position of the final position switch for the upper position (start position). Check the pneumati function.

**CAUTION!**

The pad will immediately be moved in the starting position.

Danger of crushing to hand and fingers by the moving pad.

- ⇒ Do not reach into the zone of the moving pad.
- ⇒ Keep long hair, loose clothes and jewellery distant from the zone of the moving pad.
- ⇒ Danger of striking by the moving rods.  
Do not reach or bend into the zone of the moving rods.

After error correction, the print of the label causing the error cannot be repeated without re-start of the print order.

Switch on the printing system and the display shows the main menu.

### 13.3 Troubleshooting pressure /vacuum control

#### Error: Empty vacuum plate



After verification that all holes in the pad plate are covered by the by the label and the pressure supply functions correctly, the switching threshold of vacuum sensor is to be set anew.

Press key  to access the function menu.



Press key  as long as you arrive the *Label applicator* menu.

Press key  to select the menu.

Press key  until the inputs and outputs are represented.

With keys  and  the appropriate output for setting and/or resetting of output signals can be selected.

With keys  and  the appropriate output can be set and/or reset.

Press key  to change to output O<sub>7</sub> and switch on the vacuum valve with key  (1 = On).

Place the label which is to be printed below the pad so that all suction holes are covered by the label. By the applied vacuum the label remains under the pad.

In case of correct operation, the input value I<sub>5</sub> should represent the value 1 (see display). Otherwise the switching threshold of vacuum sensor must be set with the right rotary potentiometer (B, see Figure 38) in that way that the switching threshold changed the value from 0 to 1. Turn the rotary potentiometer (B, Figure 38) clockwise and/or counterclockwise.

Remove the label from the pad. The input value I<sub>5</sub> should indicate the value 0. If a label is sucked again to the pad, the value should change to 1.



```

IILX 54/12
-----
Input:      0101000-
Output:     0100001-
    
```

Switching limit vacuum sensor  
Input I<sub>5</sub> = 0  
  
Vacuum is switched On  
(Output O<sub>7</sub> = 1)  
  
The system recognizes that no  
label is under the pad

```

IILX 54/12
-----
Input:      0101100-
Output:     0100001-
    
```

Switching limit vacuum sensor  
Input I<sub>5</sub> = 1  
  
Vacuum is switched On  
(Output O<sub>7</sub> = 1)  
  
The system recognizes that a  
label is under the pad

**Error: Compressed air**



After verification that the compressed air supply functions correctly, the switching threshold of the pressure sensor must be set.

Press key **F** to access the function menu.

Press key  as long as you arrive the *Label applicator* menu.

Press key  to select the menu.

Press key  until the inputs and outputs are represented.

With keys  and  the appropriate output for setting and/or resetting of output signals can be selected.

With keys  and  the appropriate output can be set and/or reset.

The air pressure is set to a minimum pressure of 2.5 bar. The input value I<sub>4</sub> should now represent the value 1 (see display). Otherwise the switching threshold of pressure sensor must be set with the left rotary (A, Figure 38) in that way that the switching threshold changed the value from 0 to 1. Turn the rotary potentiometer (A, Figure 38) clockwise and/or counterclockwise.

The air pressure is set to < 2.5 bar. The input value I<sub>4</sub> should now represent the value 0. If the air pressure is set to > 2.5 bar, the value should again change to 1.

```

IILX 54/12
-----
Input:      0100000-
Output:     0100000-
    
```

Switching limit pressure sensor  
Input I<sub>4</sub> = 0  
  
The system recognizes that the  
minimum pressure of 2.5 bar is  
not set

```

IILX 54/12
-----
Input:      0101000-
Output:     0100000-
    
```

Switching limit pressure sensor  
Input I<sub>4</sub> = 1  
  
The system recognizes that the  
working pressure is ≥ 2,5 bar

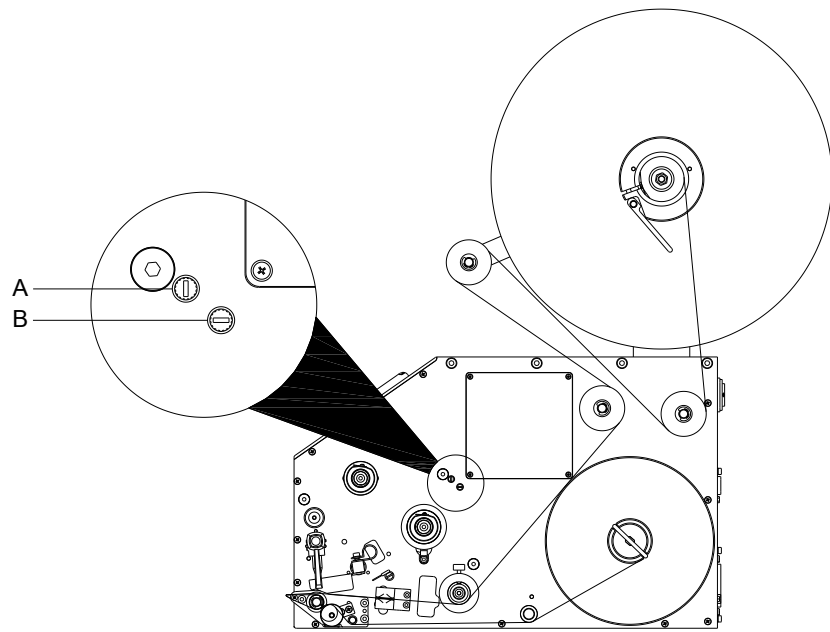
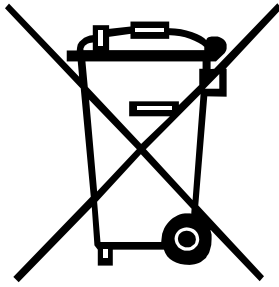

Figure 38

## 14 Environmentally-Friendly Disposal



Manufacturers of B2B equipment are obliged to take back and dispose of old equipment that was manufactured after 13 August 2005. As a principle, this old equipment may not be delivered to communal collecting points. It may only be organised, used and disposed of by the manufacturer. Valentin products accordingly labelled can therefore be returned to Carl Valentin GmbH.

This way, you can be sure your old equipment will be disposed of correctly.

Carl Valentin GmbH thereby fulfils all obligations regarding timely disposal of old equipment and facilitates the smooth reselling of these products. Please understand that we can only take back equipment that is sent free of carriage charges.

The electronics board of the printing system is equipped with a battery. This must only be discarded in battery collection containers or by public waste management authorities.

Further information on the WEEE directive is available on our website [www.carl-valentin.de](http://www.carl-valentin.de).



## 15 Index

### B

Blow tube, adjusting .....	44
Blowing air, adjusting .....	51

### C

Configuration	
Operating mode .....	31
Parameter .....	31, 32
Connections	
Installation .....	26
Control valves .....	47, 48
Cover, removing	
Electronics .....	18
Pneumatic .....	18

### D

Device overview	
Front view .....	14
Rear view .....	15
Service unit .....	16
Dispenser mode .....	54
D-SUB, Signal assignment .....	57
D-SUB, technical data .....	58

### E

Environmentally-friendly disposal .....	65
Error messages	
Applicator .....	61, 62
Printing system .....	61

### F

Function menu (printing system)	
Application modes .....	33, 34
Blow time .....	35
Cleaning time .....	36
Input/Output .....	38
Labelling signal .....	37
Operating modes .....	33
Pressure control .....	35
Pressure time .....	35
Quick-Apply delay .....	36
Roll on time .....	36
Stroke timeout .....	36
Support delay Off .....	34
Support delay On .....	34
Test functions .....	37
Transverse axis .....	36
Vacuum control .....	35
Vacuum delay .....	34
Waiting position .....	35

### H

Holes (blow tube), opening .....	43
----------------------------------	----

<b>I</b>	
Installation to printing system .....	22
Instructions .....	5
Intended use .....	5, 6
Interface, applicator .....	57
<b>L</b>	
Labels, apply .....	13
Labels, loading .....	53
<b>O</b>	
Operating conditions .....	9, 10, 11, 12
Options	
Quick apply .....	27
Shock absorber .....	28
<b>P</b>	
Pad	
Adjusting .....	43
Installation .....	25
Movement speed .....	49
Pad, aligning	
Height adjustment .....	41
In print direction .....	41
Side adjustment .....	42
Pads, models	
Blow pad .....	17
Roll-on pad .....	17
Tamp pad .....	17
Pin assignment .....	57
Product description .....	13
<b>Q</b>	
Quick apply .....	27
<b>S</b>	
Safety instructions .....	7
Safety marking .....	8
Scope of delivery .....	21
Shock absorber .....	28
Signal assignment, D-SUB .....	57
Signal diagrams	
Print-Apply .....	39
Standard operation .....	55
Stopper	
Adjusting .....	45, 46
Supporting air, adjusting .....	50
<b>T</b>	
Technical data .....	19
Technical data, D-SUB .....	58
Transfer ribbon, loading .....	53
Troubleshooting	
Pressure control .....	62
Vacuum control .....	62

**U**

Universal tamp pad  
Piercing (standard tamp pad) ..... 23  
Preparing (spring-mounted tamp pad)..... 24

**V**

Vacuum, adjusting ..... 50



---

Carl Valentin GmbH  
Neckarstraße 78 – 86 u. 94 . 78056 Villingen-Schwenningen  
Phone +49 7720 9712-0 . Fax +49 7720 9712-9901  
info@carl-valentin.de . www.carl-valentin.de