

SPE

Operating Manual



Copyright by Carl Valentin GmbH / 7987005.0817

Information on the scope of delivery, appearance, performance, dimensions and weight reflect our knowledge at the time of printing.

We reserve the rights to make modifications.

All rights, including those regarding the translation, are reserved.

No part of this document may be reproduced in any form (print, photocopy or any other method) or edited, copied or distributed electronically without written permission from Carl Valentin GmbH.

Due to the constant further development of our devices discrepancies between manual and device can occur.

Please check www.carl-valentin.de for the latest update.

Trademarks

All named brands or trademarks are registered brands or registered trademarks of their respective owners and may not be separately labelled. It must not be concluded from the missing labelling that it is not a registered brand or a registered trademark.

Carl Valentin print modules comply with the following safety guidelines:

CE EG Low-Voltage Directive (73/32/EEC)
EG Electromagnetic Compatibility Directive (89/336/EEC)



Carl Valentin GmbH

Postfach 3744
78026 Villingen-Schwenningen
Neckarstraße 78 – 86 u. 94
78056 Villingen-Schwenningen

Phone +49 7720 9712-0
Fax +49 7720 9712-9901

E-Mail info@carl-valentin.de
Internet www.carl-valentin.de

Table of contents

Table of contents	3
1 Introduction	5
1.1 General Instructions	5
1.2 Intended use	5
1.3 Important notes.....	6
1.4 Connector pin assignment.....	7
2 Safety notes	9
2.1 Operating conditions.....	11
3 Technical Data	15
3.1 Control inputs and outputs (version I)	18
3.2 Control inputs and outputs (version II)	22
3.3 Signal diagrams.....	26
4 Installation	27
4.1 Setting up the print module	27
4.2 Connecting the print module	28
4.3 Switching the print module on and off	28
4.4 Initiation of the print module	29
5 Loading media	31
5.1 Loading label roll in peel off mode.....	31
5.2 Loading label roll in passing mode	32
5.3 Loading transfer ribbon	33
6 Keyboard	35
6.1 Keyboard assignment (standard)	35
6.2 Keyboard assignment (text entry/customized/memory card)	36
7 Function menu	39
7.1 Print settings.....	43
7.2 Label layout	44
7.3 Device settings	46
7.4 Dispenser I/O.....	49
7.5 Interface.....	51
7.6 Emulation.....	53
7.7 Date & time.....	54
7.8 Service functions	55
7.9 Main menu.....	58
8 Options	59
8.1 Ribbon save.....	59
8.2 Network	59
8.3 Scanner	60
9 Memory Card	63
10 Maintenance and cleaning	69
10.1 General cleaning	70
10.2 Cleaning the Transfer Ribbon Drawing Roller.....	70
10.3 Cleaning the print roller	71
10.4 Cleaning the printhead	72
10.5 Cleaning the label photocell	73
10.6 Replacing the printhead (general)	74
10.7 Replacing FlatType printhead	75
10.8 Adjusting FlatType printhead.....	76
10.9 Replacing CornerType printhead	78
10.10 Adjusting CornerType printhead.....	79

11	Error correction	81
12	Additional information	91
12.1	Column printing	91
12.2	Password	92
12.3	Hotstart	94
12.4	Backfeed/delay	96
12.5	Transmission photocells	98
12.6	Ultrasonic photocell (option)	99
13	Environmentally-Friendly Disposal	101
14	Index	103

1 Introduction

1.1 General Instructions

Basic information and warning references with the corresponding signal words for the danger level are as follows specified in this manual:



DANGER identifies an extraordinarily great and immediate danger which could lead to serious injury or even death.



WARNING identifies a possible danger would could lead to serious bodily injury or even death if sufficient precautions are not taken.



WARNING of cutting injuries.
Pay attention that cutting injuries caused by blades, cutting devices or sharp-edged parts are avoided.



WARNING of hand injuries.
Pay attention that hand injuries caused by closing mechanical parts of a machine/equipment are avoided.



WARNING of hot surfaces.
Pay attention so as not to come into contact with hot surfaces.



CAUTION indicates a potentially dangerous situation which could lead to moderate or light bodily injury or damage to property.



NOTICE gives you tips. They make a working sequence easier or draw attention to important working processes.



Gives you tips on protecting the environment.



Handling instruction



Optional accessories, special fittings

Datum

Information in the display

1.2 Intended use

The print module is a state-of-the-art device which complies with the recognized safety-related rules and regulations. Despite this, a danger to life and limb of the user or third parties could arise and the print module or other property could be damaged while operating the device.

The print module may only be used while in proper working order and for the intended purpose. Users must be safe, aware of potential dangers and must comply with the operating instructions. Faults, in particular those which affect safety, must be remedied immediately.

The print module is solely intended to print suitable media which have been approved by the manufacturer. Any other or additional use is not intended. The manufacturer/supplier is not liable for damage resulting from misuse. Any misuse is at your own risk.

Intended use includes heeding the operating manual, including the maintenance recommendations/regulations specified by the manufacturer.

1.3 Important notes

The print module can be used in thermal as well as in thermal transfer applications.

The print module is equipped with 8 vector, 6 bitmap and 6 proportional fonts. It can be printed inverse, in italic format or 90 degrees turned fonts.

The handling of our durable print module is easy and comfortable. The device settings are made with the keys of the foil keyboard. At each time the two-line display shows the current status.

By the use of a 32 Bit processor and a large main memory of 4MB also for large labels (optional up to a length of 3000 mm) a large print is possible.

An enormously high print quality is obtained by most modern printhead technology.

By a new-developed electronics a maximum print speed of up to 300 mm/s can be achieved. Time-saving update of the firmware is possible via the interface. The print module can be adapted by the large selection of options to each function.

As default, print modules of this series are equipped with a parallel and serial interface. The print module automatically recognizes by which interface it is controlled.

Time-saving update is possible by interface.

Thanks to the large number of options the print module can be adapted to each task.

1.4 Connector pin assignment

Control unit

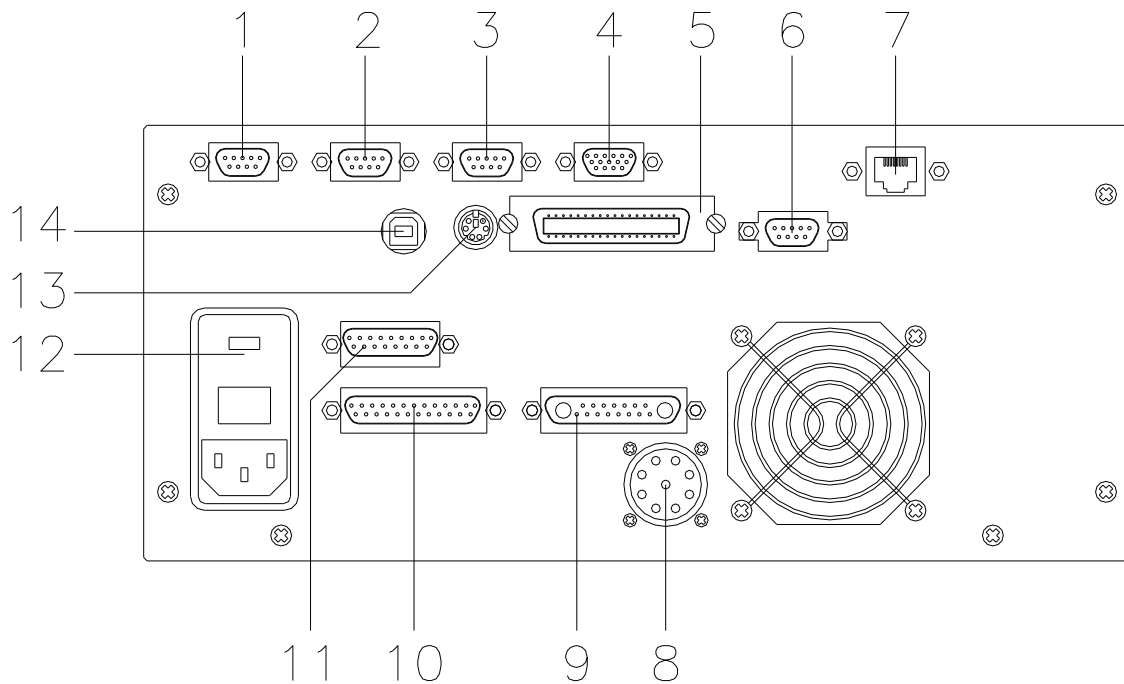
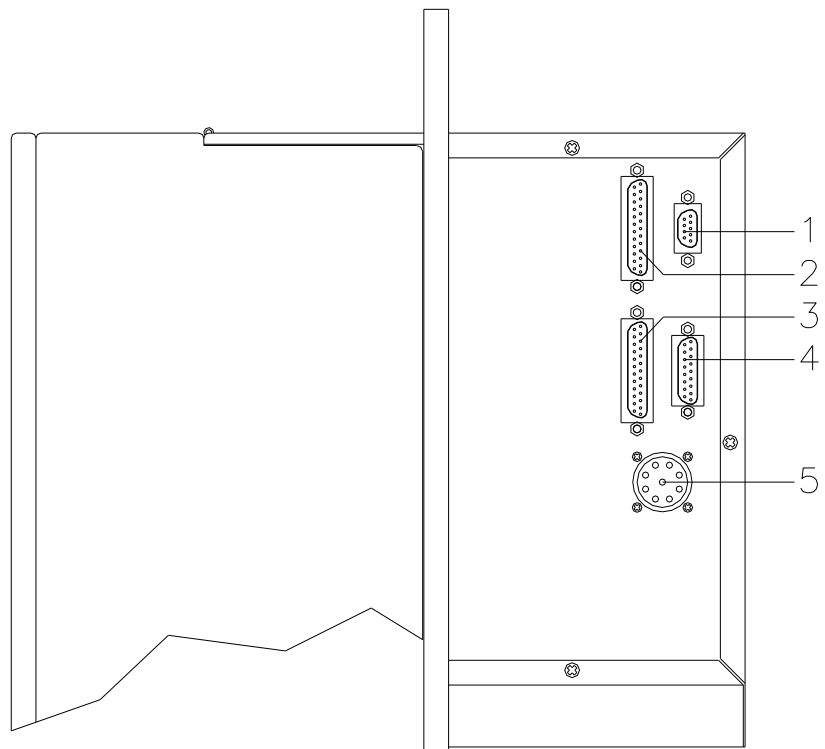

Figure 1

- | | | |
|------|---------------------------------|-------------------------|
| 1 = | External output 1-4 (Output I) | |
| 2 = | External input 1-4 (Input I) | |
| 3 = | External output 5-8 (Output II) | |
| 4 = | Version I | Version II |
| | SUB-D plug 9-pin | SUB-D plug 15-pin |
| | External input 5-8 | External bushing I/O-24 |
| | see chapter 3.1 | see chapter 3.2 |
| 5 = | Centronics interface | |
| 6 = | RS-232 interface | |
| 7 = | Ethernet interface (option) | |
| 8 = | Connecting cable power | |
| 9 = | Connecting cable motor | |
| 10 = | Connecting cable signal | |
| 11 = | Connecting cable sensors | |
| 12 = | Power supply | |
| 13 = | PS/2 keyboard connection | |
| 14 = | USB interface | |

Rear panel of mechanics**Figure 2**

- 1 = Connection for winder
- 2 = Motors
- 3 = Printhead signal
- 4 = Sensors
- 5 = Printhead power

2 Safety notes

The print module is designed for power supply systems from 230 V. Connect the print module only to electrical outlets with a ground contact.

Couple the print module to devices using extra low voltage only.

Before making or undoing connections, switch off all devices involved (computer, printer, accessories etc.).

Operate the print module in a dry environment only and do not get it wet (sprayed water, mist etc.).

Do not operate the print module in explosive atmosphere and not in proximity of high voltage power lines.

Operate the print module only in an environment protected against abrasive dust, swarf and other similar impurity.

In case of cleaning and maintenance with an open cover, ensure that clothing, hair, jewellery and similar personal items do not contact the exposed rotating parts.



NOTICE!

With the open printing unit (due to construction) the requirements of EN60950-1 regarding fire protection casing are not fulfilled. These must be ensured by the installation into the end device.

The print unit can get hot during printing. Do not touch the printhead during operation. Cool down the print unit before changing material, removal or adjustment.

Carry out only the actions described in these operating instructions. Any work beyond this may only be performed by the manufacturer or upon agreement with the manufacturer.

Unauthorized interference with electronic modules or their software can cause malfunctions.

Other unauthorized work or modifications to the direct print module can endanger operational safety.

Always have service work done in a qualified workshop, where the personnel have the technical knowledge and tools required to do the necessary work.

There are warning stickers on the direct print modules that draw your attention to dangers. Therefore the warning stickers are not to be removed as then you and others cannot be aware of dangers and may be injured.

The print module must be integrated with the Emergency Stop circuit when it is incorporated into the overall machine.

All isolating safety equipment must be installed before starting-up the machine.

**DANGER!**

Danger to life and limb from power supply!

⇒ Do not open the casing.

**CAUTION!**

Two-pole fuse.

⇒ Before opening the housing cover, disconnect the device from the mains supply and wait approx. 2 - 3 minutes until the power supply unit has discharged.

2.1 Operating conditions

Before initial operation and during operation these operating conditions have to be observed to guarantee safe and interference-free service of our print modules.

Therefore please carefully read these operating conditions.

Shipment and storage of our print modules are **only** allowed in original packing.

Installation and initial operation of print module is only allowed if operating conditions were **fulfilled**.

Commissioning is prohibited until it can be established that, where relevant, the machine into which the partly completed machinery is to be incorporated complies with the provisions of Machinery Directive 2006/42/EC.

Initial operation, programming, operation, cleaning and service of our print modules are only recommended after careful study of our manuals.

Operation of print module is only allowed by especially trained persons.



NOTICE!

Perform trainings regularly. Content of the training are chapter 2.1 (Operating conditions), chapter 5 (Loading media) and chapter 10 (Maintenance and cleaning).

These indications are also valid for someone else's equipment supplied by us.

Only use original spare and exchange parts.

Please contact the manufacturer with respect to spare/wear parts.

Conditions for installation place

The installation place of print module should be even, free of vibration and currents of air are to be avoided.

The print modules have to be installed to ensure optimal operation and servicing.

Installation of power supply

The installation of the power supply to connect our print modules has to be effected according to the international rules and regulations, especially the recommendations of one of the three following commissions:

- International Electronic Commission (IEC)
- European Committee for Electro technical Standardisation (CENELEC)
- Verband Deutscher Elektrotechniker (VDE)

Our print modules are constructed according to VDE and have to be connected to a grounded conductor. The power supply has to be equipped with a grounded conductor to eliminate internal interfering voltage.

Technical data of power supply

Power line voltage and power line frequency: See type plate
Allowable tolerance of power line voltage: +6% ... -10% of nominal value
Allowable tolerance of power line frequency: +2% ... -2% of nominal value
Allowable distortion factor of power line voltage: $\leq 5\%$

Anti-Interference measures

In case your net is infected (e.g. by using thyristor controlled machines) anti-interference measures have to be taken. You can use one of the following possibilities:

- Provide separate power supply to our print modules.
- In case of problems please connect capacity-decoupled isolation transformer or similar interference suppressor in front of our print modules.

Stray radiation and immunity from disturbance

Emitted interference according to EN 61000-6-4: 08-2002

- Interference voltage to wires according to EN 55022: 09-2003
- Interference field power according to EN 55022: 09-2003

Immunity to interference according to EN 61000-6-2: 03-2006

- Stray radiation against discharge of static electricity according to EN 61000-4-2: 12-2001
- Electromagnetic fields according to EN 61000-4-3: 11-2003
- Fast transient burst according to EN 61000-4-4: 07-2005
- Surge according to EN 61000-4-5: 12-2001
- High-frequency tension according to EN 61000-4-6: 12-2001
- Voltage interruption and voltage drop according to EN 61000-4-11: 02-2005

**NOTICE!**

This is a machine of type A. This machine can cause interferences in residential areas; in this case it can be required from operator to accomplish appropriate measures and be responsible for it.

Machine safety

- EN 415-2 - Safety of packaging machines
- EN 60204-1:2006 - Safety of machinery - Electrical equipment of machines - Part 1

Connecting lines to external machines

All connecting lines have to be guided in shielded lines. Shielding has to be connected on both sides to the corner shell.

It is not allowed to guide lines parallel to power lines. If a parallel guiding cannot be avoided a distance of at least 0.5 m has to be observed.

Temperature of lines between: $-15 \dots +80 \text{ }^\circ\text{C}$.

It is only allowed to connect devices which fulfil the request 'Safety Extra Low Voltage' (SELV). These are generally devices which are checked corresponding to EN 60950.

Installation of data lines

The data cables must be completely protected and provide with metal or metallised connector housings. Shielded cables and connectors are necessary, in order to avoid radiant emittance and receipt of electrical disturbances.

Allowable lines

Shielded line: $4 \times 2 \times 0,14 \text{ mm}^2$ ($4 \times 2 \times \text{AWG } 26$)
 $6 \times 2 \times 0,14 \text{ mm}^2$ ($6 \times 2 \times \text{AWG } 26$)
 $12 \times 2 \times 0,14 \text{ mm}^2$ ($12 \times 2 \times \text{AWG } 26$)

Sending and receiving lines have to be twisted in pairs.

Maximum line length: with interface V 24 (RS-232C) - 3 m
(with shielding)
with Centronics - 3 m (with shielding)
with USB - 3 m
with Ethernet - 100 m

Air convection

To avoid inadmissible heating, free air convection has to be ensured.

Limit values

Protection according IP: 20

Ambient temperature $^\circ\text{C}$ (operation): Min. +5 Max. +40

Ambient temperature $^\circ\text{C}$ (transport, storage): Min. -25 Max. +60

Relative air humidity % (operation): Max. 80

Relative air humidity % (transport, storage): Max. 80
(bedewing of print modules not allowed)

Guarantee

We do not take any responsibility for damage caused by:

- Ignoring our operating conditions and operating manual.
- Incorrect electric installation of environment.
- Building alterations of our print modules.
- Incorrect programming and operation.
- Not performed data protection.
- Using of not original spare parts and accessories.
- Natural wear and tear.

When (re)installing or programming our print modules please control the new settings by test running and test printing. Herewith you avoid faulty results, reports and evaluation.

Only specially trained staff is allowed to operate the print modules.

Control the correct handling of our products and repeat training.

We do not guarantee that all features described in this manual exist in all models. Caused by our efforts to continue further development and improvement, technical data might change without notice.

By further developments or regulations of the country illustrations and examples shown in the manual can be different from the delivered model.

Please pay attention to the information about admissible print media and the notes to the print module maintenance, in order to avoid damages or premature wear.

We endeavoured to write this manual in an understandable form to give and you as much as possible information. If you have any queries or if you discover errors, please inform us to give us the possibility to correct and improve our manual.

3 Technical Data

	SPE 104/8	SPE 106/12	SPE 107/12	SPE 108/12	SPE 160/12	SPE 162/12
Print Resolution	203 dpi	300 dpi	305 dpi	300 dpi	305 dpi	300 dpi
Max. Print Speed	200 mm/s	200 mm/s	300 mm/s	300 mm/s	200 mm/s	150 mm/s
Print Width	104 mm	106,6 mm	106,6 mm	108,4 mm	160 mm	162,2 mm
Passage Width	116 mm	116 mm	116 mm	116 mm	176 mm	176 mm
Printhead	FlatType	FlatType	CornerType	FlatType	CornerType	FlatType
Labels						
Adhesive Labels or Continuous Material	on rolls : paper, cardboard, textile, synthetics					
Max. Material Weight	220 g/m ² (larger on demand)					
Min. Label Width	25 mm	25 mm	25 mm	25 mm	50 mm	50 mm
Min. Label Height	15 mm	15 mm	15 mm	15 mm	15 mm	15 mm
Max. Label Height						
Standard	1900 mm	1200 mm	1200 mm	1200 mm	800 mm	800 mm
Option Ethernet	1700 mm	1100 mm	1100 mm	1100 mm	700 mm	700 mm
Label Sensor	transmission					
Transfer Ribbon						
Ink	outside/inside					
Max. Roll Diameter	Ø 90 mm					
Core Diameter	25,4 mm / 1"					
Max. Length	450 m					
Max. Width	110 mm	110 mm	110 mm	110 mm	170 mm	170 mm
Dimensions in mm (width x height x depth)						
Print Mechanics H = 300 / D = 245	300 x H x D	300 x H x D	300 x H x D	300 x H x D	360 x H x D	360 x H x D
Control Unit	285x140x360					
Weight in kg						
Print Mechanics	11	11	11	11	12	12
Control Unit	9	9	9	9	9	9
Electronics						
Processor	RISC					
RAM	4 MB					
Slot	for Compact Flash carte type I					
Battery Cache	for Real-Time clock (storage of data with shut-down)					
Warning Signal	Acoustic signal when error					
Interfaces						
Serial	RS-232C (up to 57600 Baud), RS-422 + RS-485 (option)					
Parallel	Centronics					
USB	1.1					
Ethernet	10/100 Base-T (option)					
Operating Conditions						
Nominal Voltage	Standard: 230 V / 50...60 Hz Option: 115 V / 50...60 Hz					
Max. Power	360 VA					
Fuse Values	Standard: 2x T3,15 A 250 V Option: 2x T5A 250 V					
Operating Temperature	5 ... 40 °C					
Humidity	max. 80% (not condensing)					

Operation Panel	SPE 104/8	SPE 106/12	SPE 107/12	SPE 108/12	SPE 160/12	SPE 162/12
Keys	Test print, function menu, quantity, CF Card, feed, enter, 4 x cursor					
LCD Display	2 x 16 characters					
Settings						
	Date, time, shift times 10 language settings (others on demand) Label and device parameters, interfaces, password protection, variables					
Monitoring						
Stop printing if	End of ribbon, end of labels, printhead open					
Status report	Extensive status print with information about settings e.g. print length counter, runtime counter, photocell interface and network parameters Printout of all internal fonts and all supported bar codes					
Fonts						
Font types	6 Bitmap fonts 8 Vector fonts/TrueType fonts, 6 proportional fonts Other fonts on demand					
Character sets	Windows 1250 up to 1257, DOS 437, 850, 852, 857, UTF-8 All West and East European Latin, Cyrillic, Greek and Arabic (option) characters are supported Other character sets on demand					
Bitmap fonts	Size in width and height 0,8 ... 5,6 Zoom 2 ... 9 Orientation 0°, 90°, 180°, 270°					
Vector fonts/TrueType fonts	Size in width and height 1 ... 99 mm Variable zoom Orientation 0°, 90°, 180°, 270°					
Font attributes	Depending on character font bold, italic, inverse, vertical					
Font width	Variable					
Bar Codes						
1D bar codes	CODABAR, Code 128, Code 2/5 interleaved, Code 39, Code 39 extended, Code 93, EAN 13, EAN 8, EAN ADD ON, GS1-128, Identcode, ITF 14, Leitcode, Pharmacode, PZN 7 Code, PZN 8 Code, UPC-A, UPC-E					
2D bar codes	Aztec Code, CODABLOCK F, DataMatrix, GS1 DataMatrix, MAXICODE PDF 417, QR Code					
Composite bar codes	GS1 DataBar Expanded, GS1 DataBar Limited, GS1 DataBar Omnidirectional, GS1 DataBar Stacked, GS1 DataBar Stacked Omnidirectional, GS1 DataBar Truncated					
	All bar codes are variable in height, module width and ratio. Orientation 0°, 90°, 180°, 270°. Optionally with check digit and human readable line.					
Software						
Configuration	ConfigTool					
Process control	NiceLabel					
Label software	Labelstar Office Lite Labelstar Office					
Windows driver	Windows 7 [®] 32/64 Bit Windows 8 [®] 32/64 Bit Windows 8.1 [®] 32/64 Bit Windows 10 [®] 32/64 Bit Windows Server 2008 [®] (R2) 64 Bit Windows Server 2012 [®] 64 Bit Windows Server 2012 [®] (R2) 64 Bit					

Technical modifications are subject to change.

Standard equipment

- Left or right version
- Multi-tasking operating system
- Double-spaced, multilingual display
- 2-slot PCMCIA drive
- Date / time
- IBM keyboard connection
- Inputs/outputs
- Windows printer driver

Optional equipment

- Transfer ribbon savings (only 107/12 and 160/12)
- Ultrasonic photocell
- Label dispensing unit
- Label unwinding unit
- Rewinder for supporting paper
- Compact Flash Card slot
- PCMCIA cards
- Compact Flash cards
- RS422 interface
- RS485 interface
- Ethernet interface
- Label design software Labelstar Office

3.1 Control inputs and outputs (version I)

Plug connection - back side of control unit

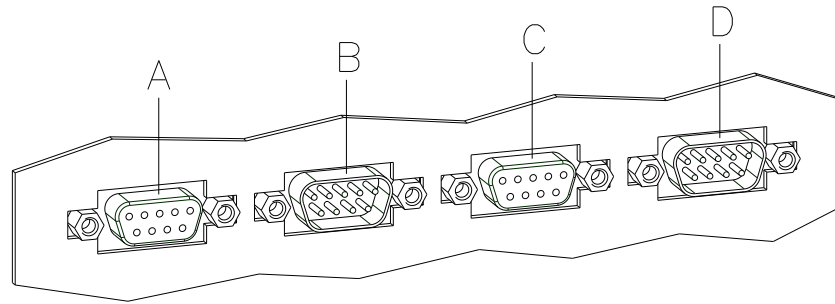

Figure 3

- A = External output 1-4 (Output I)
- B = External input 1-4 (Input I)
- C = External output 5-8 (Output II)
- D = External input 5-8 (Input II)

Control outputs

By means of the signal outputs different operating states of the print module can be queried.

The signal outputs are provided by two 9-pin SUB-D-bushings (OUTPUT I and OUTPUT II) on the back side of the control unit.

They consist of optocoupler semiconductor sections, which are connected through and/or blocked according to different operating states.

The maximum allowable current in a semiconductor section is $I_{max} = 30 \text{ mA}$.

Output I
Figure 3, A

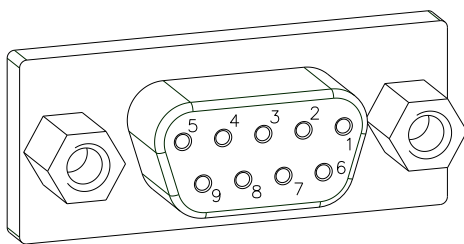

Figure 4

PIN (bushing)	Output I
	Out 1: Error message Each error status such as ribbon error is displayed.
	Out 2: Print order The print module was activated by a print order.
	Out 3: Generation The current label data is processed. In case in dispensing mode either dispensing photocell or dispensing photocell continuous is selected it is indicated if a label is under photocell and ready to pick up.
	Out 4: Layout print The content of print memory is transferred on the printable medium by means of the printhead.

Example

Connection of a lamp to a 24V relay by Out 1:

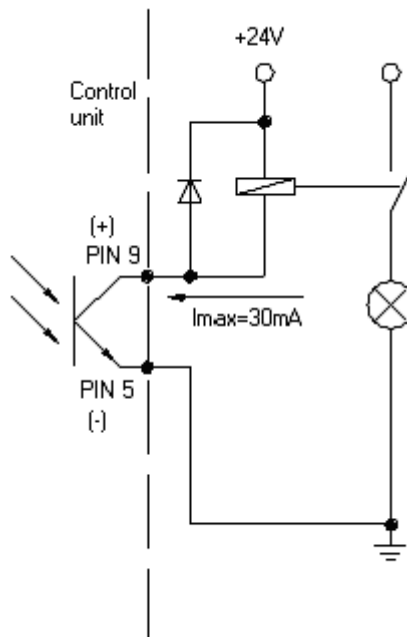

Figure 5

Output II
Figure 3, C

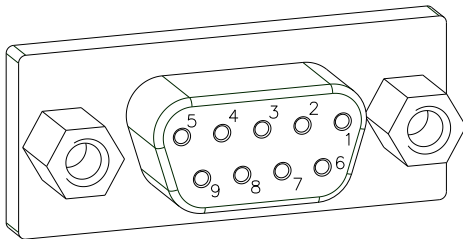

Figure 6

PIN (bushing)	Output II
<p>9 (+) 5 (-)</p>	<p>Out 5: Print-Ready signal</p> <p>It is indicated if the print module is ready to process a start impulse. In contrary to the print order signal, the generating time is taken into consideration.</p>
<p>8 (+) 7 (-)</p>	<p>Out 6: Not used</p>
<p>6 (+) 2 (-)</p>	<p>Out 7: Not used</p>
<p>4 (+) 3 (-)</p>	<p>Out 8: Prior warning of transfer ribbon end</p>

Control inputs

By means of the control inputs it is possible to control printing. The control inputs at Input I are electroplated separated and have to be provided with an external tension source. The signal level is active "HIGH".

Input I
Figure 3, B

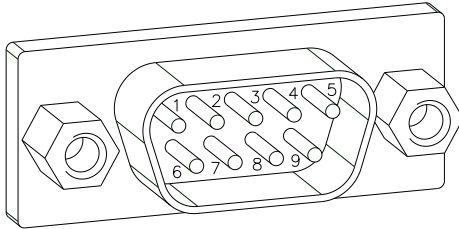

Figure 7

PIN (pin)	Input I
	In 1: Print start
	In 2: Not used
	In 3: Reset external counter
	In 4: Not used

Example

Connection of a switch with 24V voltage supply by In 1:

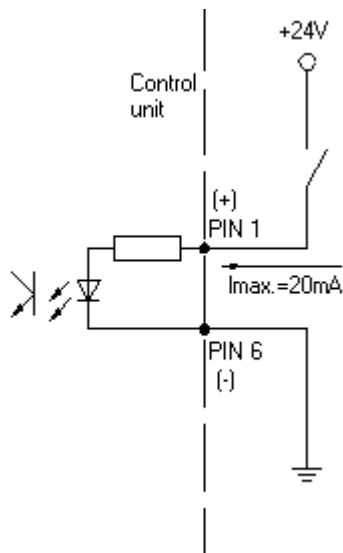

Figure 8

Input II
Figure 3, D

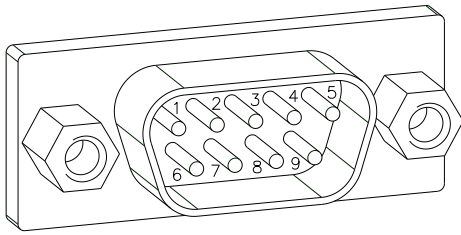

Figure 9

PIN (pin)	Input II
	In 5: Not used
	In 6: Not used
	In 7: Not used
	In 8: Not used

3.2 Control inputs and outputs (version II)

Plug connection - back side of control unit

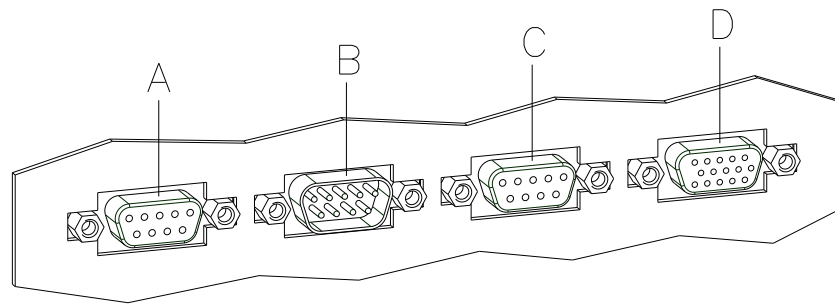

Figure 10

- A = External output 1-4 (Output I)
- B = External input 1-4 (Input I)
- C = External output 5-8 (Output II)
- D = External bushing 15pin (I/O-24)

Control outputs

By means of the signal outputs different operating states of the print module can be queried.

The signal outputs are provided by two 9-pin SUB-D-bushings (OUTPUT I and OUTPUT II) on the back side of the control unit.

They consist of optocoupler semiconductor sections, which are connected through and/or blocked according to different operating states.

The maximum allowable current in a semiconductor section is
 $I_{max} = 30 \text{ mA}$.

Output I
 Figure 10, A

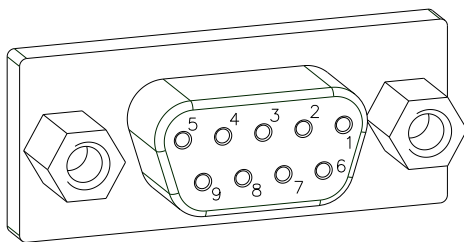

Figure 11

PIN (bushing)	Output I
	Out 1: Error message Each error status such as ribbon error is displayed.
	Out 2: Print order The print module was activated by a print order.
	Out 3: Generation The current label data is processed. In case in dispensing mode either dispensing photocell or dispensing photocell continuous is selected it is indicated if a label is under photocell and ready to pick up.
	Out 4: Layout print The content of print memory is transferred on the printable medium by means of the printhead.

Example

Connection of a lamp to a 24V relay by Out 1:

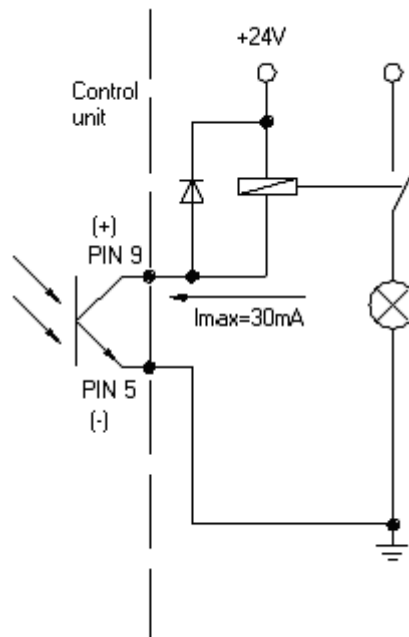

Figure 12

Output II
Figure 10, C

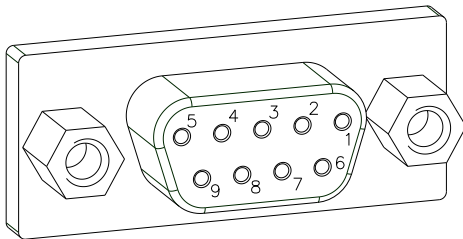

Figure 13

PIN (bushing)	Output II
	Out 5: Print-Ready signal It is indicated if the print module is ready to process a start impulse. In contrary to the print order signal, the generating time is taken into consideration.
	Out 6: Not used
	Out 7: Not used
	Out 8: Prior warning of transfer ribbon end

Control inputs

By means of the control inputs it is possible to control printing. The control inputs at Input I are galvanic separated and have to be provided with an external tension source. The signal level is active "HIGH".

Input I
Figure 10, B

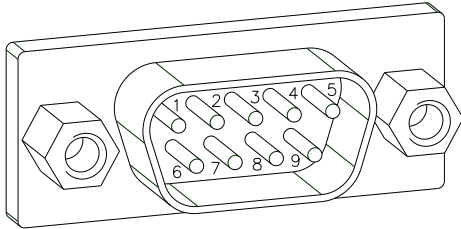

Figure 14

PIN (pin)	Input I
	In 1: Print start
	In 2: Not used
	In 3: Reset external counter
	In 4: Not used

Example

Connection of a switch with 24V voltage supply by In 1:

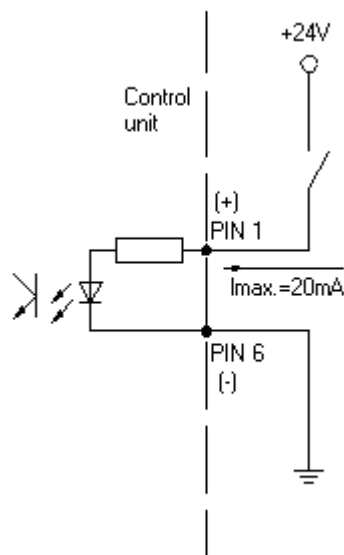

Figure 15

External bushing I/O-24
Figure 10, D

This input is executed as 15-pole and provides user-sided 24V/100mA.
In case of using this bushing, exists **no galvanic separation**.

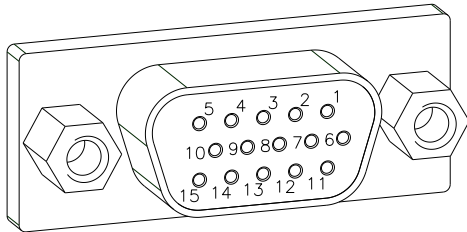
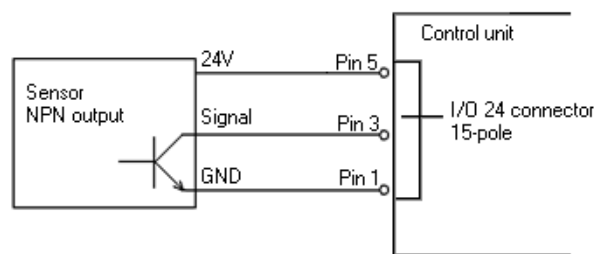

Figure 16

PIN	Function	
1, 6	Gnd	
5, 10	24 V / 100 mA	
3	Print start (NPN initiator)	
2	Print start (PNP initiator)	
4		Print start by potential-free contact
14		
7		Signal lamp 24 V / 100 mA (error)
13		

Example 1



Connection scheme for creating a start signal by a sensor with NPN output

Example 2

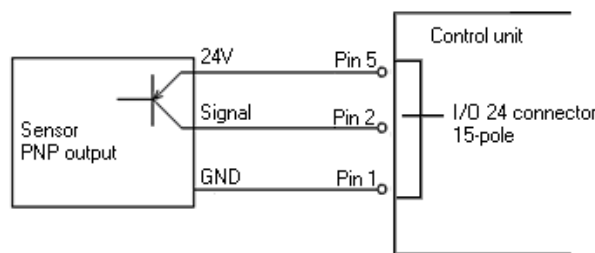

Connection scheme for creating a start signal by a sensor with PNP output

Example 3

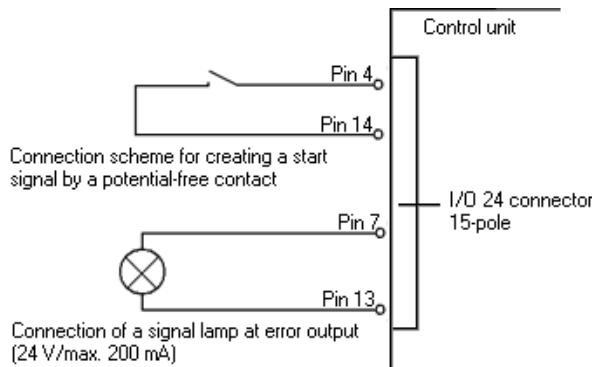

Connection scheme for creating a start signal by a potential-free contact

Connection of a signal lamp at error output (24 V/max. 200 mA)

3.3 Signal diagrams

Dispensing mode: I/O dynamic

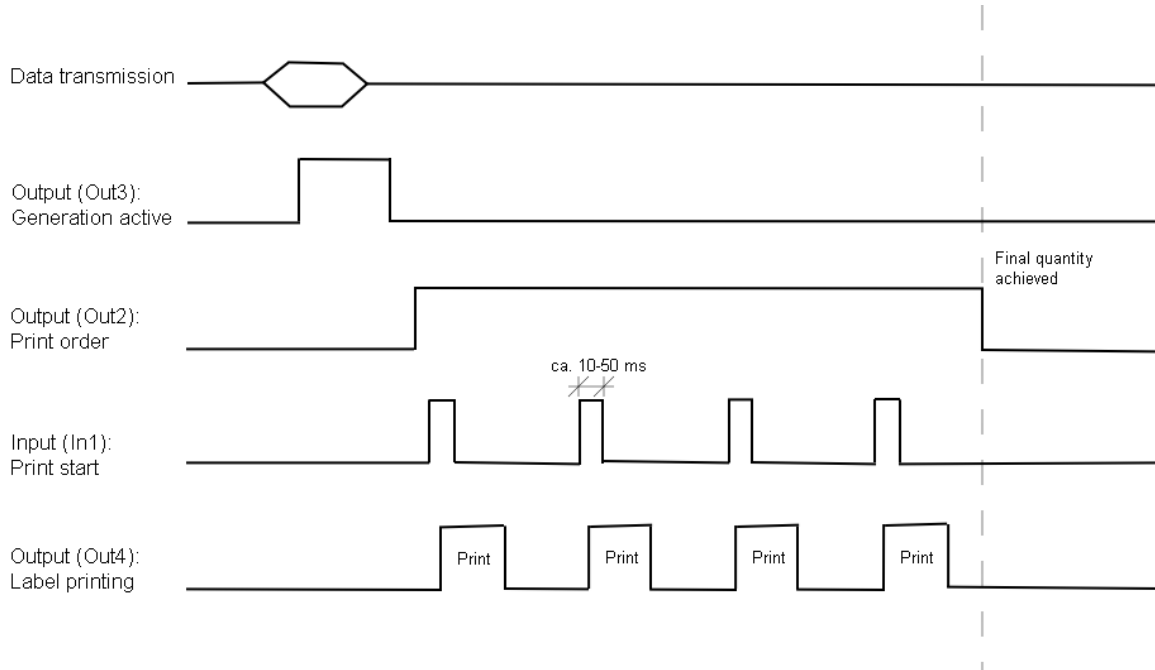

Figure 17

Dispensing mode: I/O dynamic continuous

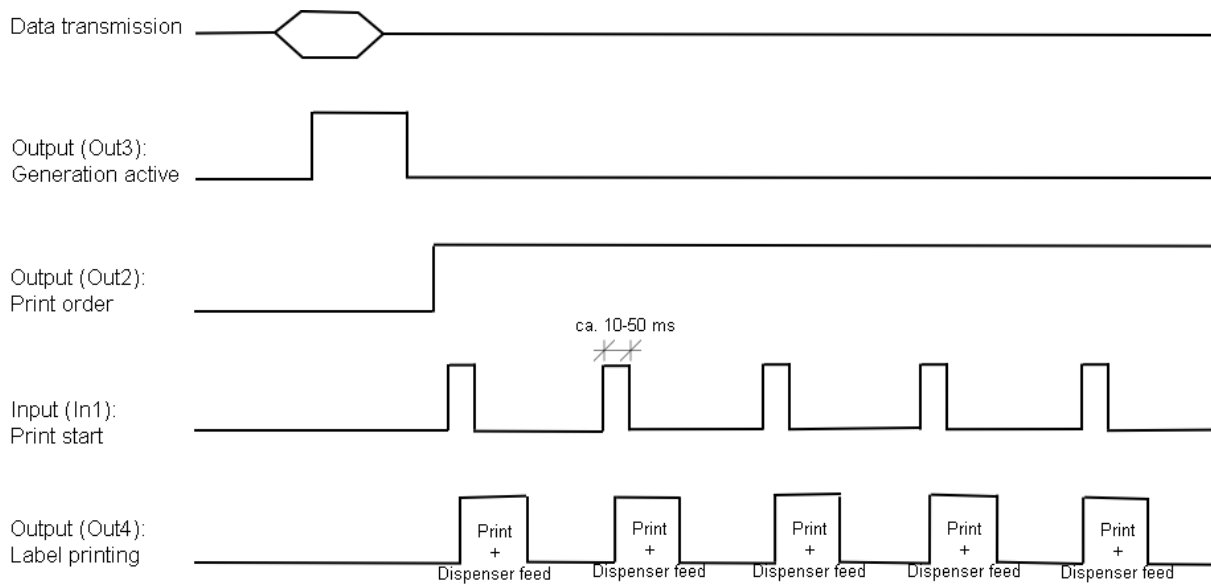

Figure 18

4 Installation

Unpack the print mechanics and control unit

- ⇒ Lift the print mechanics and control unit out of the box.
- ⇒ Check the print mechanics and control unit for transport damages.
- ⇒ Check delivery for completeness.

Scope of delivery

- Print mechanics.
- Control unit.
- Power cable.
- Connection cable (printhead/motors, sensors, power).
- I/O accessories (female connectors for I/O, I/O 24 cable).
- 1 transfer ribbon roll.
- Empty core, mounted on transfer ribbon rewinder.
- Cleaning foil for printhead.
- Documentation.
- CD with printer drivers.



NOTICE!

Retain original packaging for subsequent transport.

4.1 Setting up the print module



CAUTION!

The print module and the print media can be damaged by moisture and water.

- ⇒ Set up the print module only in a dry place protected from sprayed water.

- ⇒ Mount the print mechanics on a vibration-free and air draught-free.
- ⇒ Open cover of print module.
- ⇒ Remove foam transportation safeguards near the printhead.

4.2 Connecting the print module

Connecting to the power supply

The print module is equipped with a versatile power supply unit. The device may be operated with a mains voltage of 230 V / 50-60 Hz without any adjustments or modifications.



CAUTION!

The print module can be damaged by undefined switch-on currents.

⇒ Set the power switch to '0' before plugging in the print module.

⇒ Insert power cable into power connection socket (2).

⇒ Insert plug of power cable into a grounded electrical outlet.

Connecting to a computer or to a computer network



NOTICE!

Insufficient or missing grounding can cause faults during operation.

Ensure that all computers and connection cables connected to the print module are grounded.

⇒ Connect print module to computer or network with a suitable cable.

4.3 Switching the print module on and off

Once all connections have been made:

⇒ Switch on the control unit.
After switching on the control unit the main menu appears which shows the model type, current date and time

4.4 Initiation of the print module

Insert label material and transfer ribbon (see chapter 5. Loading media, on page 31).

Start measuring in menu 'Label layout/Measure label' (see chapter 7.2 Label layout, on page 44).

Press key  to finish measuring.

**NOTICE!**

To enable correct measuring, at least two completed labels have to be passed through (not for continuous labels).

During measuring the label and gap length small differences can occur. Therefore the values can be set manually in 'Label layout/Label and Gap' menu.

5 Loading media

5.1 Loading label roll in peel off mode

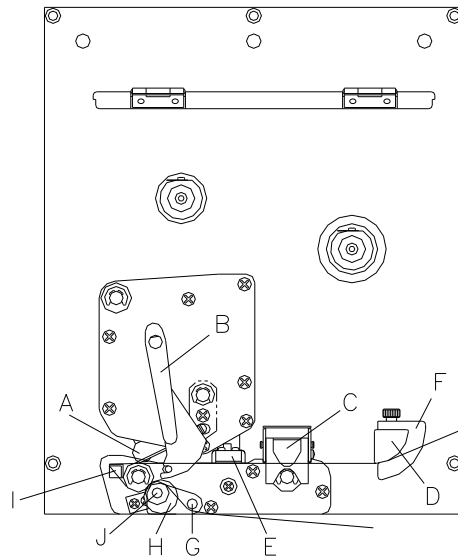

Figure 19

1. Open the print module cover.
2. Open printhead (A) by turning the red pressure lever (B) anticlockwise.
3. Open the engine support (C) by pulling the red bolt to the top.
4. Lead the label material (minimum height = 15 mm) below the label guiding (D) and printhead (A) and take care that the labels run through the photocell (E).
5. Press the engine support (C) again to the bottom until it locks.
6. In order to move the printhead (A) down, turn the red pressure lever (B) in clockwise direction until it locks.
7. Adjust the adjusting rings (F) of the label guiding to the width of material.
8. Lift the dispensing whip (G) by pulling the knurled knob (I) outwards to the bottom.
9. Strip some labels from the backing paper and lead the backing material over the dispensing whip (I) and between the plastic roll (J) and the dispensing whip-shaft (G).
10. Press again the dispensing whip (G) to the top and lock it.
11. Lead the supporting paper to the back and fix it at a rewinding unit.
12. Enter the offset value in the 'Dispenser I/O' menu.
13. Close the print module cover.

5.2 Loading label roll in passing mode

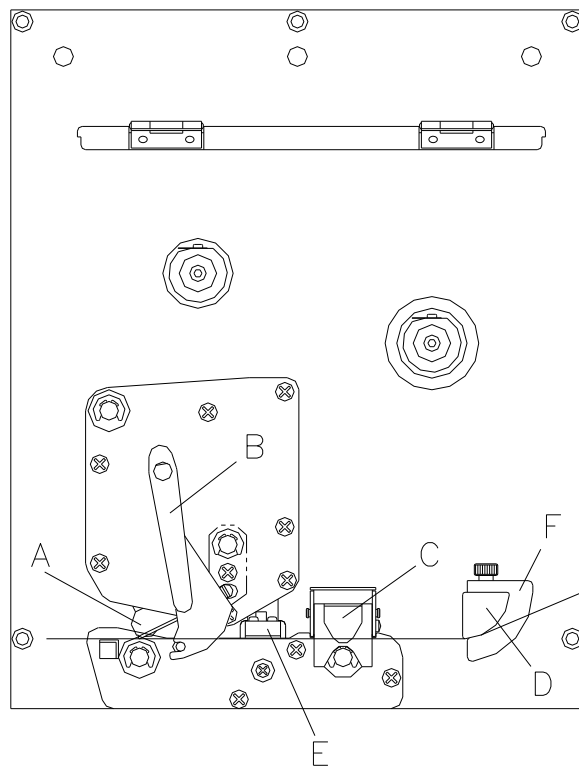

Figure 20

1. Open the print module cover.
2. Open printhead (A) by turning the red pressure lever (B) anticlockwise.
3. Open engine support (C) by pulling the red bolt to the top.
4. Lead the label material below the label guiding (D) and take care that the label runs through the photocell (E).
5. Press the engine support (C) again downwards until it locks.
6. In order to move the printhead (A) down, turn the red pressure lever (B) in clockwise direction until it locks.
7. Adjust the adjusting rings (F) of the label guiding to the width of material.
8. Close the print module cover.

5.3 Loading transfer ribbon



NOTICE!

For the thermal transfer printing method it is necessary to load a ribbon, otherwise when using the print module in direct thermal print it is not necessary to load a ribbon. The ribbons used in the print module have to be at least the same width as the print media. In case the ribbon is narrower than the print media, the printhead is partly unprotected and this could lead to early wear and tear.

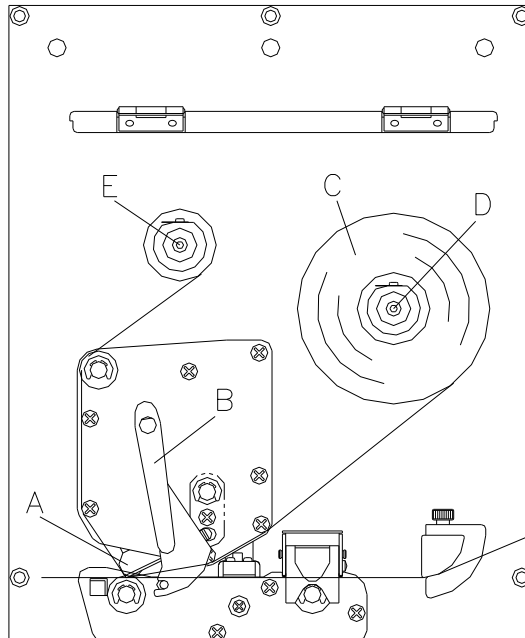

Figure 21



NOTICE!

Before a new transfer ribbon roll is loaded, the printhead must be cleaned using printhead and roller cleaner (97.20.002). For detailed information, please see page 72.

The handling instructions for the use of Isopropanol (IPA) must be observed. In the case of skin or eye contact, immediately wash off the fluid thoroughly with running water. If the irritation persists, consult a doctor. Ensure good ventilation.

1. Open the print module cover.
2. Open printhead (A) by turning the red pressure lever (B) anticlockwise.
3. Load the transfer ribbon roll (C) with outer winding onto the unwinding roll (D).
4. Place an empty ribbon roll on the winding roll (E) and lead the transfer ribbon below the printhead.
5. Fix the ribbon with an adhesive tape in operating direction at the empty roll of the rewinding roll (E).
Check the perfect run of the transfer ribbon by turning the rewinding roll (E) several times anticlockwise.

6. In order to move the printhead (A) down, turn the red pressure lever (B) in clockwise direction until it locks.
7. Close the print module cover.

















**NOTICE!**

As for the electrostatic unloading the thin coating of the thermal printhead or other electronic parts can be damaged, the transfer ribbon should be antistatic.

The use of wrong materials can lead to malfunctions and the guarantee can expire.

6 Keyboard

6.1 Keyboard assignment (standard)

Key	Meaning	Function
	Main menu	Back to main menu. Activate test print. Delete stopped print order.
	Up	Printhead upwards.
	Down	Printhead downwards.
	Function menu	Change to function menu. In function menu, one menu item back.
	Feed	In main menu, one label feed. In function menu, change to next menu item.
	Start/Stop	Confirm settings in function menu. Stop and continue current print order. Delete stopped print order with key  . No further label of the print order is printed.
	Memory	Change to Compact Flash card menu.
	Quant	Change to number of copies menu. Press keys  and  to select the number of copies that are to print.
	Forwards	In main menu, printing carriages moves to the before set service position. Change to next input field. Press keys  and  to change values.
	Backwards	In main menu, printing carriage moves back to zero point. Change to previous input field. Press keys  and  to change values.
0 - 9	Function keys	Parameter selection (e.g. speed).
F1 + F2	Function keys	No function.
C	Function key	Delete complete entry.
E	Function key	Confirm entry. After confirmation of settings, return to the main menu.

6.2 Keyboard assignment (text entry/customized/memory card)

The control unit of the print module is equipped with an alphanumeric character block which allows the user to enter parameters and customised variables without the connection of an external keyboard. Each key contains letters and similar to the use of a mobile phone (like sms) a direct and time-saving input is possible.

The mode is displayed in the first line at the right position so the user can control in which input mode is selected.

As the input is almost done with characters from one mode, the characters are divided in different groups. Following input modes are available:

```
Article no.  0
1234_
```

```
Color code  M
AB_
```

Symbol	Mode
0	Standard, starting with figures
M	Starting with capital letters
m	Starting with small letters
A	Input Alt
a	Input Alt, is switched off after one character

Mode 0

This mode is displayed as default. At first the figure which corresponds to the key is displayed, then all capital and afterwards the small letters.

Mode M

At first all capital, then the small letters and at last the corresponding figure.

Mode m











At first all small letters, then the figure and at last the capital letters.

Mode A

This mode can be used for the creation of special characters. The desired character can be displayed by the assigned number by entering the ANSI code. Please note that the ANSI code has to consist of three digits, i.e. you have possible to enter a zero first.

Mode a

Same as mode A. After input of the selected ANSI code the machine, however, changes back to the previously selected input mode.

Key	Meaning	Function
	Main menu	Back to main menu. Activate test print. Delete stopped print order.
	Up	For customized variables, change between single entries.
	Down	For customized variables, change between single entries.
	Funktion menu	No function.
	Vorschub	Entry confirmation. Change to the main menu.
	Start/Stopp	Confirmation/end of entry.
	Memory	Entry mode selection.
	Quant	Delete character at cursor position. If the cursor is behind the last character, the last one is deleted. Character is only deleted if it was before entered by the character block.
	Forwards	Cursor one position to the right.
	Backwards	Cursor one position to the left.
0 - 9	Character block	Entry of desired data.
F1 + F2	Function keys	No function.
C	Function key	Delete complete entry. The entry is only deleted if it was entered by the character block.
E	Function key	Confirm entry. After confirmation of settings, return to the main menu.

7 Function menu

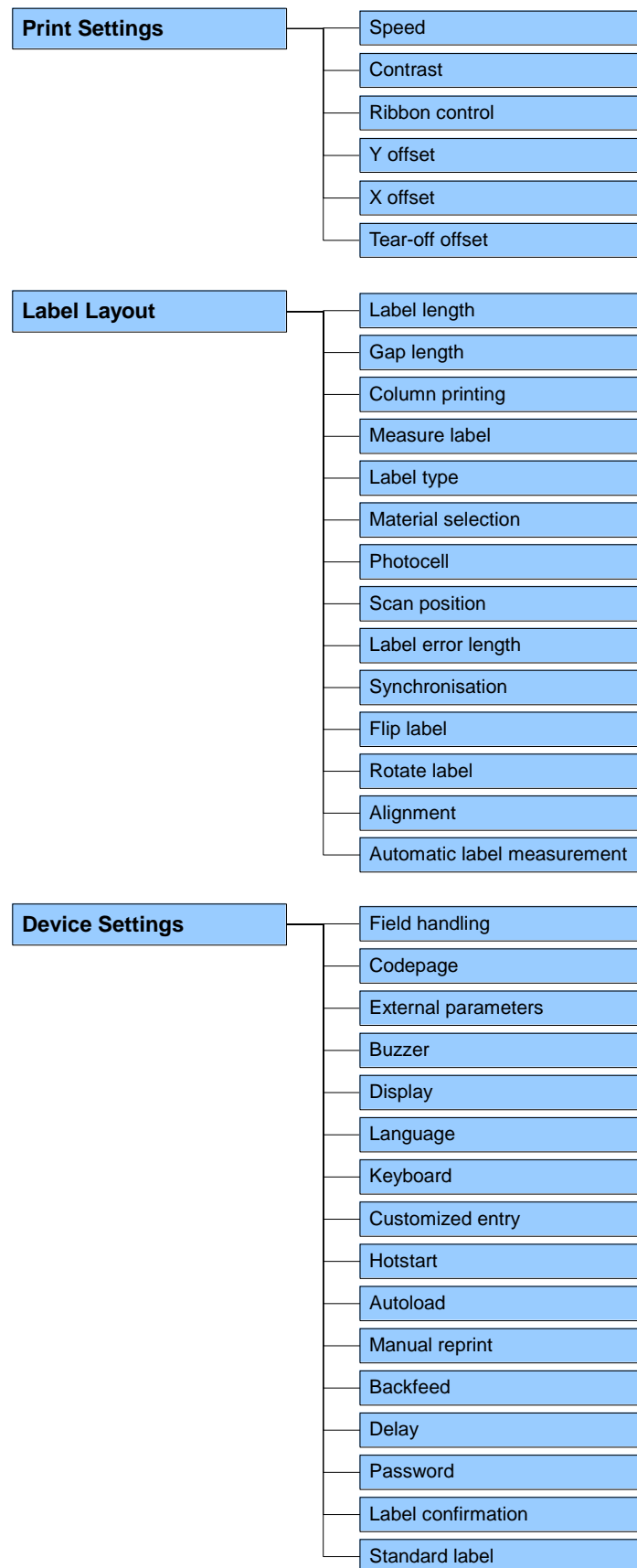

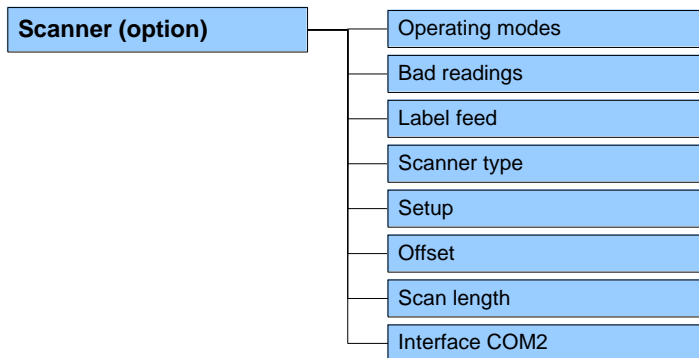
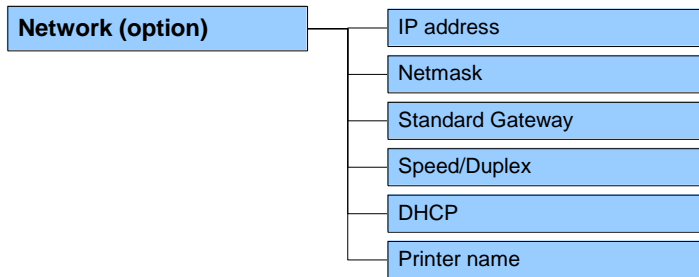
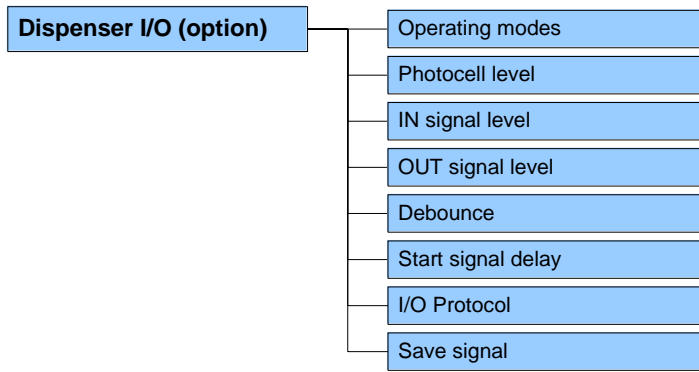

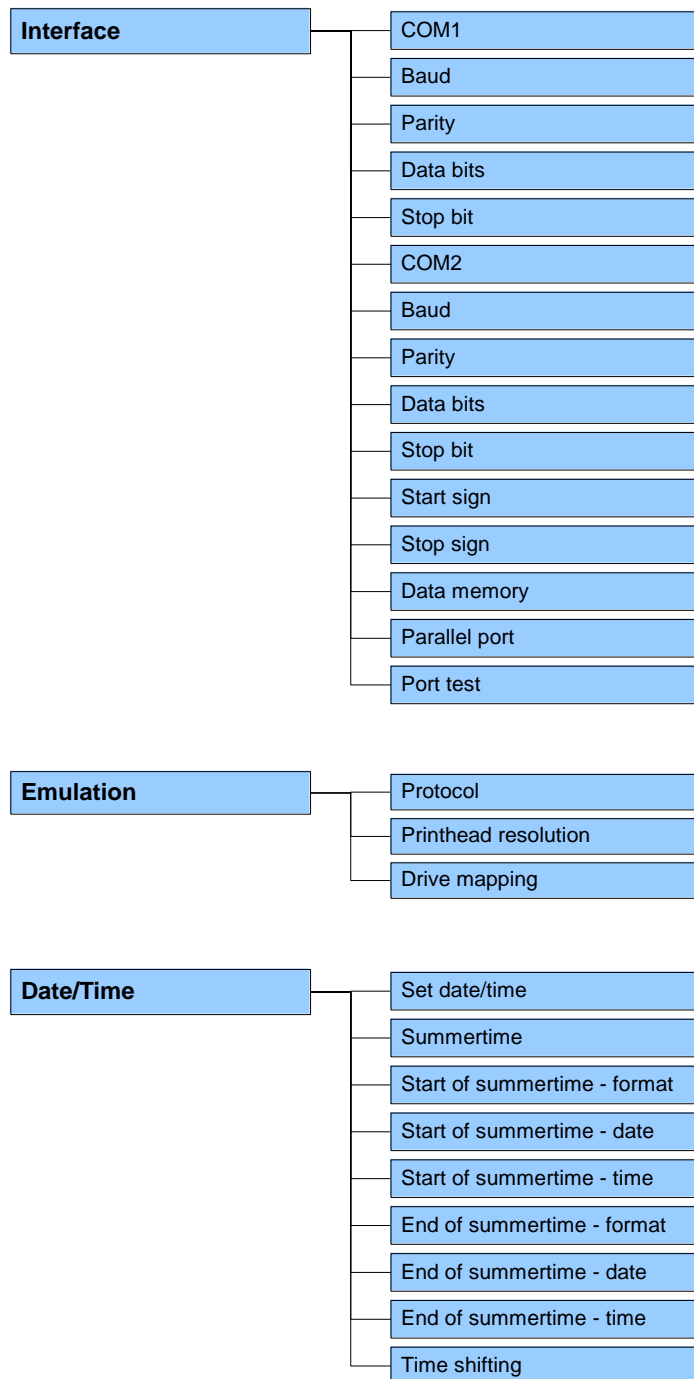

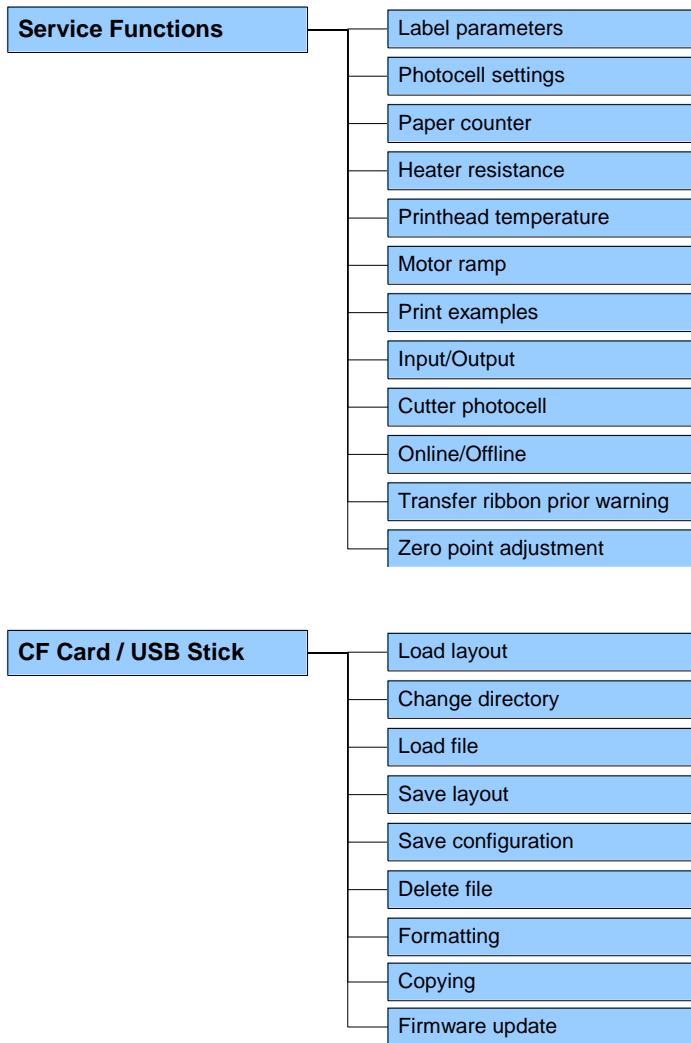

7.1 Print settings

After switching on the control unit, the display shows the following:

```
SPE 107-12 KC
16/11/07 14:35
```

Press key **F** to access the function menu.

```
Function Menu
Print Settings
```

Press key  to select the menu.

```
Speed:      100
Contrast:   100
```

Speed:

Indication of print speed in mm/s.

Contrast:

Indication of contrast in %.

Value range: 10% ... 200 %.

Step size: 10%

Press key  to arrive at the next menu item.

```
Ribbon Control
ON strong sens.
```

Transfer ribbon control:

Examination if the transfer ribbon roll is to end or if the ribbon was torn at the unwinding roll.

Off: The ribbon control is deselected, i.e. the print module continues without an error message.

On: The ribbon control is selected, i.e. the current print order is interrupted and an error message appears at the display of control unit.

strong sensibility: The print module reacts immediately to the end of the transfer ribbon.

weak sensibility: The print module reacts at approx. 1/3 more slowly to the end of the transfer ribbon.

Press key  to arrive at the next menu item.

```
Y Displacement
Offs (mm):  1.5
```

Y displacement:

Indication of initial point displacement in mm. The label is moved vertically.

Value range: -30.0 ... +90.0.

Press key  to arrive at the next menu item.

```
X Displacement
Offs (mm): -1.5
```

X displacement:

Indication of displacement in X direction. The fields on the label are moved.

Value range: -90.0 ... +90.0.

Press key  to arrive at the next menu item.

```
Tear off
Offs (mm):  7.5
```

Tear off:

Indication of value to which the last label of a print order is moved forward and is moved back to the label start at a new print start.

Labels can be torn after termination of the print order without a loss of labels by tearing.

Default: 12 mm.

Value range: 0 ... 50.0 mm.

7.2 Label layout

Press key **F** to access the function menu.

Press key  as long as you arrive at the 'Label layout' menu.

Press key  to select the menu.

```
Function Menu
Label layout
```

```
Label:      50.3
Gap:       2.0
```

Label:

Indication of label length in mm.

Gap:

Indication of distance between two labels in mm (not for continuous labels).

Minimum value: 1 mm.

Press key  to arrive at the next menu item.

```
Label Width 20.0
Columns:    4
```

Column printing:

Indication of width of one label as well as how many labels are placed side by side (see chapter 12.1 Column printing, on page 91).

Press key  to arrive at the next menu item.

```
Measure Label
Start measure
```

Measure label:

Press key  to start measuring. The print module stops automatically after termination of measuring. The determined values are displayed and saved.

Press key  to arrive at the next menu item.

```
Label type
Adhesive labels
```

Label type:

Generally adhesive labels are set. Press key  to select continuous labels. If the menu label length/gap length contains a gap value, this value is added to the label length.

Press key  to arrive at the next menu item.

```
Material
Typ 2
```

Material:

Selection of the used label and transfer ribbon material.

Press key  to arrive at the next menu item.

```
Photocell    SP
Trans.normal 10
```

Photocell:

Selection of the used photocell.

The following possibilities are available:

Transmission photocell normal, transmission photocell inverse and ultrasonic photocell (optional)

(see chapter 12.5 Transmission photocells, on page 98).

Scan position (SP):

Entry of percental label length by that the label end is searched.

Marks onto the label can be skipped.

Errorlength Sync
mm: 149 ON

Press key  to arrive at the next menu item.

Label error length:

In case an error occurs, indication after how many mm a message appears in the display.

Value range: 1 mm ... 999 mm.

Synchronisation:

On: If a label is missed on the liner an error message is displayed.

Off: Missing labels are ignored, i.e. it is printed into the gap.

Press key  to arrive at the next menu item.

Flip label
Off

Flip label:

The axis of reflection is in the middle of the label. If the label width was not transferred to the printer, automatically the default label width i.e. the width of the printhead is used. It is recommended to use labels with the same width as the printhead. Otherwise this can cause problems in positioning.

Press key  to arrive at the next menu item.

Label type
Adhesive labels

Rotate label:

According to standard the label is printed ahead with a rotation of 0°. If the function is activated, the label is rotated by 180° and printed in reading direction.

Press key  to arrive at the next menu item.

Alignment
Left

Alignment:

The adjustment of label is effected only after 'flip/rotate label', i.e. the adjustment is independent of the functions flip and rotate label.

Left: The label is aligned at the left-most position of printhead.

Centre: The label is aligned at central point of printhead.

Right: The label is aligned at right-most position of printhead.

Press key  to arrive at the next menu item.

Auto measure
On

Measure label automatically:

On: After switching on the printer, the loaded label is automatically measured.

Off: In order to start the measurement procedure you have to change to the corresponding menu.

7.3 Device settings

Press key **F** to access the function menu.

Press key  as long as you arrive at the 'Device settings' menu.

Press key  to select the menu.

Function Menu
Device Settings

Field Handling
OFF

Field handling:

Off: The complete print memory is deleted.

Keep graphic: A graphic res. a TrueType font is transferred to the print module once and stored in the printer internal memory. For the following print order only the modified data is transferred to the print module. The advantage is the saving of transmitting time for the graphic data.

The graphic data created by the print module itself (internal fonts, bar codes, ...) is generated only if they were changed. The generating time is saved.

Delete graphic: The graphics res. TrueType fonts stored in the printer-internal memory is deleted but the other fields are kept.

Press key  to arrive at the next menu item.

Codepage
GEM German

Codepage:

Indication of the font used in the print module.

The following possibilities are available:

ANSI character set / Codepage 437 / Codepage 850 / GEM German / GEM English / GEM French / GEM Swedish / GEM Danish

Press key  to arrive at the next menu item.

ext. Parameters
ON

External parameters:

Label dimension only: The parameters for label length, gap length and label width can be transferred to the printer. All other parameter settings are to be made directly at the printer.

On: Sending parameters such as print speed and contrast via our label creation software to the print module. Parameters which are set directly at the print module before are no longer considered.

Off: Only settings made directly at the print module are considered.

Press key  to arrive at the next menu item.

Buzzer Display
ON 3

Buzzer:

On: An acoustic signal is audible when pressing a key.

Value range: 1 ... 7.

Off: No signal is audible.

Display:

Setting of display contrast.

Value range: 0 ... 7.

Press key  to arrive at the next menu item.

Printer Language
English

Language:

Selection of language in which you want to display the text in the display of control unit.

At the moment the following languages are available: German, English, French, Spanish, Portuguese, Dutch, Italian, Danish, Finnish, Polish

Keyboard Layout
England

Press key  to arrive at the next menu item.

Keyboard layout:

Selection of region for the desired keyboard layout.

The following possibilities are available: Germany, England, France, Greece, Spain, Sweden and US.

Customized Entry
On

Press key  to arrive at the next menu item.

Customized entry:

On: The question referring the customized variable appears once before the print start at the display.

Auto: The question referring the customized variable appears after every printed label.

Off: No question appears at the display. In this case the stored default value is printed.

Press key  to arrive at the next menu item.

Hotstart
Off

Hotstart:

On: Continue an interrupted print order after switching on the print module anew.

(Only if print module is equipped with a memory card)

Off: After switching off the print module the complete data is lost (see chapter 12.3 Hotstart, on page 94).

Press key  to arrive at the next menu item.

Autoload
On

Autoload:

On: A label which was loaded once from the memory card can be loaded again automatically after a restart of printer.

Procedure: The used label is saved onto memory card. The label is loaded from memory card and printed. After switching the printer Off and again On, the label is loaded from memory card automatically and

can be printed again. Press key  to start a print with indication of number of labels.



NOTICE!

The last loaded label from memory card is always again loaded after a restart of printer.

Off: After a restart of printer the last used label must be again loaded manually from the memory card.





NOTICE!

A common use of the functions Autoload and Hotstart is not possible. For a correct Autoload procedure the Hotstart must be deactivated in the printer.

Press key  to arrive at the next menu item.

manual reprint
Yes

Manual reprint:

Yes: In case an error occurred and print module is in stopped mode then you can reprint the last printed labels by means of keys  and .

No: Only blank labels were advanced.

Backfd. Standard
Delay (s): 0.60

Press key  to arrive at the next menu item.

Backfeed / Delay:

Backfeed: The backfeed was optimised in the operating modes dispenser (optional), cutter (optional) and tear off. Now, when driving into the offset, the following label is 'pre-printed' if possible and therefore the backfeed of label is no necessary and time can be saved.

Delay: The adjustable deceleration time is only for mode 'backfeed automatic' of importance (see chapter 12.4 Backfeed/delay, on page 96).

Press key  to arrive at the next menu item.

Password Prot.
Active

Password:

By a password several functions can be blocked, so the user cannot work with them. There are several applications in which the use of password protection makes sense (see chapter 12.2 Password, on page 92).

Press key  to arrive at the next menu item.

Label confirm.
On

Label confirmation:

On: A new print order is only printed after confirmation at the device. An already active continuing print order is printed as long as the confirmation is effected at the device.

Off: No query appears at the display of control unit.

Press key  to arrive at the next menu item.

Standard label
Off

Standard label:

On: If a print order is started without previous definition of label, the standard label is printed.

```

  POS 108/12 R
  V1.50 (Build 0001 )

  NO LABEL DATA
  
```

Off: If a print order is started without previous definition of label, an error message appears in the display.

7.4 Dispenser I/O

In order to operate the print module in dispensing mode a print order has to be started and the print module has to be in 'waiting' mode.

Press key **F** to access the function menu.

Press key  as long as you arrive at the 'Dispenser I/O' menu.

```
Dispense IO ST
Offs (mm): 0.0
```

Press key  to select the menu.

In the first line of the display the dispenser mode can be selected. In the second line the dispenser offset which is approx. 18 mm can be set.

Press key  to arrive at the next operating mode.

Dispenser I/O operating modes

Off:

It is printed without the labels are dispensed.

I/O static:

The input signal evaluated, i.e. it is printed as long as the signal exists. The number of labels which was entered at the print start is printed.

The set dispenser offset is not taken into consideration.

I/O static continuous:

You can find the description of this operating mode in chapter I/O static.

Continuous means that it is printed as long as new data is transferred via interface

The set dispenser offset is not taken into consideration.

I/O dynamic:

The external signal is evaluated dynamically, i.e. is the print module in 'waiting' mode a single label is printed at each signal changing. After the print the set dispenser offset is executed, i.e. a backfeed is effected.

I/O dynamic continuous:

You can find the description of this operating mode in chapter I/O dynamic.

Continuous means that it is printed as long as new data is transferred via interface.



Photocell:

The print module is controlled via photocell. The print module prints automatically a label if the user takes away the label at the dispensing ledge. The print order is finished when the target number of labels is reached.

Photocell continuous:

You can find the description of this operating mode in chapter photocell.

Continuous means that it is printed as long as new data is transferred via interface.

Press key  to select additional parameters or press keys **F** and/or  to return to the main menu.

Additional parameters for dispenser I/O

After selection of desired dispenser I/O operating mode, press key  to select additional parameters.

PC-switch-level
0.1 0 1.2

Photocell switch level:

First value = Indication of current photocell level.
Second value = Indication if a label (value = 1) or if no label (value = 0) was found.
Third value = Indication of switch level. The modification of this value is only taken into consideration for the operating modes Photocell and Photocell continuous.

Press key  to arrive at the next parameter.

IN signal level
1s2x3+4x5x6x7x8x

IN signal level:

Indication of signal at which a print order is started.

- + = active signal level is 'high' (1)
- = active signal level is 'low' (0)
- x = not activated signal level
- s = status can be affected by interface*

The modification of the signal level is only taken into consideration for the operating modes I/O static, I/O dynamic, I/O static continuous and I/O dynamic continuous.

Press key  to arrive at the next parameter.

OUT signal level
1+2+3+4+5+6+7+8+

OUT signal level:

Indication of signal level for output signal.

- + = active signal level is 'high' (1)
- = active signal level is 'low' (0)
- s = status can be affected by interface*

Press key  to arrive at the next parameter.

Debounce (ms)
50

Debounce:

Indication of debounce time of the dispenser input. The setting range of the debounce time is between 0 and 100 ms.
In case the start signal is not clear then you can debounce the input by means of this menu item.

Press key  to arrive at the next parameter.

Start delay (s)
1.00

Start signal delay:

Indication in time per second of the delay for the start signal.
Value range: 0.00 ... 9.99.

Press key  to arrive at the next parameter.

IO protocol
Port: Off

IO protocol:

Indication of interface at which the modifications of input signals and output signals (I/O) are sent.

* in combination with Netstar PLUS

```
Save signal
On
```

Press key  to arrive at the next parameter.

Save signal:

On: The start signal for the next label can already be released during printing the current label. The signal is registered from the print module. The print module starts printing the next label immediately after finishing the current one. Therefore time can be saved and performance be increased.

Off: The start signal for the next label can only be released if the current label is printed to the end and the print module is again in 'waiting' state (output 'ready' set). If the start signal was released already before, so this is ignored.

7.5 Interface

Press key  to access the function menu.

Press key  as long as you arrive at the 'Interface' menu.

```
Function Menu
Interface
```

Press key  to select the menu.

```
COM1 BAUD P D S
0 9600 N 8 2
```

COM1:

0 - serial interface Off.

1 - serial interface On.

2 - serial Interface On, no error message occurs in case of a transmission error.

Baud rate:

Indication of bits which are transferred per second.

Following values are possible: 1200, 2400, 4800, 9600, 19200, 38400 and 57600.

P = Parity:

N - No parity; E - Even; O - Odd

Please observe that the settings correspond to those of the print module.

D = Data bits:

Setting of data bits. Value range: 7 or 8 Bits.

S = Stop bits:

Indication of stop bits between bytes. Value range: 1 or 2 stop bits.

Press key  to arrive at the next menu item.

```
COM2 Baud P D S
0 9600 N 8 2
```

COM2:

0 - serial interface Off.

1 - serial interface On.

2 - serial Interface On, no error message occurs in case of a transmission error.

Baud rate:

Indication of bits which are transferred per second.

Following values are possible: 1200, 2400, 4800, 9600, 19200, 38400 and 57600.

P = Parity:

N - No parity
E - Even
O - Odd

Please observe that the settings correspond to those of the print module.

D = Data bits:

Setting of data bits. Value range: 7 or 8 Bits.

S = Stop bits:

Indication of stop bits between bytes. Value range: 1 or 2 stop bits.

Press key  to arrive at the next menu item.

```
Start (SOH): 01
End   (ETB): 17
```

SOH: Start of data transfer block → Hex format 01

ETB: End of data transfer block → Hex format 17

Two different start / end signs can be set. The settings are normally SOH = 01 HEX and ETB = 17 HEX. Several host computers cannot process these signs and therefore SOH = 5E HEX and ETB = 5F cannot be set.

Press key  to arrive at the next menu item.

```
Data Memory
Advanced
```

Data memory:

Standard: After starting a print order the printer buffer receives data as long as it is filled.

Advanced: During a current print order data is received and processed.

Off: After starting a print order no more data is received.

Press key  to arrive at the next menu item.

```
Parallel Port
SPP
```

Parallel port:

SPP - Standard Parallel Port

ECP - Extended Capabilities Port (grants a fast data transmission but it is only to set at PCs of newer version).



Please observe that the settings correspond to those of the PC.

Press key  to arrive at the next menu item.

```
Port test    Off
```

Port test:

Check whether the data are transferred via the interface.

Press the  and  keys to select standard (on). Press the  key and the data sent via any port (COM1, LPT, USB, TCP/IP) is printed.

7.6 Emulation

Press key **F** to access the function menu.

Press key  as long as you arrive at the 'Emulation' menu.

Press key  to select the menu.

Function menu
Emulation

Protocol
ZPL

Protocol:

CVPL: Carl Valentin Programming Language

ZPL: Zebra® Programming Language

Change between CVPL protocol and ZPL II® protocol.

Press key  to confirm the selection.

The printer performs a restart and ZPL II® commands are transformed into CVPL commands internally by the printer and then executed by the printer.

Press key  in menu protocol to arrive at the next menu item.

Head Resolution
11.8 (Dot/mm)

Printhead resolution:

At activated ZPL II® emulation the printhead resolution of the emulated printer must be set, e.g. 11.8 Dot/mm (= 300 dpi).



NOTICE!

If the printhead resolution of the Zebra® printer differs from that of the Valentin printer, then the size of objects (e.g. texts, graphics) complies not exactly.

Press key  to arrive at the next menu item.

Drive mapping
B:->A: R:->R:

Drive mapping:

The access to Zebra® drives

B: Memory Card

R: RAM Disk (standard drive, if not indicated)

is rerouted to the corresponding Valentin drives

A: Memory Card (slot 1) and/or Compact Flash

B: Memory Card (slot 2)

R: RAM Disk

This can be necessary if the available space on the RAM disk (at present. 512 KByte) is not sufficient or if bitmap fonts are downloaded to the printer and be stored permanently.





NOTICE!

As the printer build-in fonts in Zebra® printers are not available in Valentin printers, this can cause small differences in the text image.

7.7 Date & time

Press key **F** to access the function menu.

Press key  as long as you arrive at the 'Date/Time' menu.

Press key  to select the menu.

```
Function menu
Date/Time
```

```
Date 17.11.04
Time 13:28:06
```

```
Summertime
On
```

```
ST start format
WW/WD/MM
```

```
WW WD MM
last sunday 03
```

```
ST start time
02:00
```

```
ST end format
WW/WD/MM
```



```
WW WD MM
last sunday 10
```



```
ST end time
03:00
```

```
Time shifting
01:00
```

Set date and time:

The upper line of display shows the current date, the second line the current time.

With keys  and  you can change to the next or previous field.

With keys  and  you can increase and/or decrease the displayed values.

Press key  to arrive at the next menu item.

Summertime:

On: Print module automatically adjust clock for daylight saving changes.

Off: Summertime is not automatically recognized and adjusted.

Press key  to arrive at the next menu item.

Start of summertime (format):

Select the format in which you want to define beginning summertime.

The above example indicates the default setting (European format).

DD = day; WW = week; WD = weekday; MM = month; YY = year;

next day = only next day is taken into consideration

Press key  to arrive at the next menu item.

Start of summertime (date):

By means of this function you can enter the date at which summertime has to start. This entry refers to the previously selected format.

Example: summertime is automatically adjusted at last Sunday in March (03).

Press key  to arrive at the next menu item.

Start of summertime (time):

By means of this function you can define the time when you want to start summertime.

Press key  to arrive at the next menu item.

End of summertime (format):

Select the format in which you want to define end of summertime.

The above example indicates the default setting (European format).

DD = day; WW = week; WD = weekday; MM = month; YY = year;

next day = only next day is taken into consideration

Press key  to arrive at the next menu item.

End of summertime (date):

By means of this function you can define the date when you want to stop summertime. The entry refers to the previously selected format.

Example: summertime is automatically adjusted at last Sunday in October (10).

Press key  to arrive at the next menu item.

End of summertime (time):

By means of this function you can define the time when you want to stop summertime.

Press key  to arrive at the next menu item.

Time shifting:

By means of this function you can enter time shifting in hours and minutes (for automatically adjustment from summer and wintertime). This entry refers to the currently set print module time.

7.8 Service functions



NOTICE!

So that the distributor res. the print module manufacturer at the case of service can offer fast support, the print module is equipped with the Service functions menu.

Necessary information such as set parameter can read directly at the print module (see chapter 7.9, on page 58).

Press key **F** to access the function menu.

Press key  as long as you arrive at the 'Service functions' menu.

```
Function Menu
Service Function
```

Press key  to select the menu.

```
Label-Para.  3.0
A:0.3 B:3.0 C1.6
```

Label parameters: Indication of label parameters in Volt.

A: Indication of minimum value.

B: Indication of difference between minimum and maximum value.

C: Indication of trigger level. The value is ascertained while measuring and can be changed.

Press key  to arrive at the next menu item.

```
DLS RLS SLS TR H
3.5 1.5 0.0 0 0
```

Photocell parameters:

DLS: Indication of transmission photocell level in Volt.

RLS: Indication of reflexion photocell level in Volt.

SLS: Indication of peel off photocell level in Volt.

TR: Indication of transfer ribbon photocell status (either 0 or 1).

H: Indication of printhead position.

0 = printhead down

1 = printhead up

Press key  to arrive at the next menu item.

```
Paper Counter
D000007 G000017
```

Paper counter:

D: Indication of printhead attainment in meters.

G: Indication of print module attainment in meters.

Press key  to arrive at the next menu item.

```
Heater Resist.
1250
```

Heater resistance:

To achieve a high print quality, the indicated Ohm value must be set after an exchange of printhead.

Press key  to arrive at the next menu item.

```
Printhead Temp.
23
```

Printhead temperature:

Indication of printhead temperature. The printhead temperature corresponds normally to the room temperature. In case the maximum printhead temperature is exceeded, the current print order is interrupted and an error message appears at the display of control unit.

```
Motor      Ramp
++  2     --  2
```

Press key  to arrive at the next menu item.

Motor Ramp:

This function is often used for high printing speed as the tearing of transfer ribbon can be prevented.

The higher the '++' value is set, the slower the feeding motor is accelerated.

The smaller the '--' value is set, the faster the feeding motor is decelerated.

Press key  to arrive at the next menu item.

```
Print Examples
Settings
```

Print examples:

Settings: Printout of all device settings such as speed, label and transfer ribbon material.

Bar codes: Printout of all available bar code types.

Fonts: Printout of all available font types.

Press key  to arrive at the next menu item.

```
Input:  11111111
Output: 00000000
```

Input/Output:

Indication of signal level which indicates the signal a print order is started.

0 - Low

1 - High

Press key  to arrive at the next menu item.

```
Cutter-LS  CH
      1      1
```

Cutter photocell:

1 - Print module is equipped with a cutter

0 - Print module is not equipped with a cutter

CH:

1 - The cutter is in the initial position and ready for the cutting procedure.

0 - The cutter is not in the initial position. Before you are going to release a cutting procedure you first have to place the cutter in its initial position.

Press key  to arrive at the next menu item.

```
On/Offline
Off
```

Online/Offline:

This function is activated e.g. if the transfer ribbon is to be changed. It is avoided that a print order is processed although the module is not ready. If the function is activated then press the key  to change between Online and Offline mode. The respective state is indicated in the display.

Standard: Off

Online: Data can be received by interface. The keys of the foil keyboard are only active, if you changed in the Offline mode with key .

Offline: The keys of the foil keyboard are still active but received data are not processed. If the module is again in Online mode then new print orders can be again received.

TR advance warn.
On ø: 40 v: 100

Press key  to arrive at the next menu item.

TRB = Transfer ribbon advance warning:

Before the end of transfer ribbon, a signal is send by the control output.

Warning diameter:

Setting of transfer ribbon advance warning diameter.

In case you enter a value in mm then a signal appears via control output when reaching this diameter (measured at transfer ribbon roll).

Ribbon advance warning mode:

Warning: When reaching the transfer ribbon advance warning diameter, the corresponding I/O output is set.

Reduced print speed: Speed on which the printing speed is to be reduced.

Error: The printing system stops when reaching the transfer ribbon advance warning diameter with the message 'too less ribbon'.

Reduced print speed:

Setting of the reduced print speed in mm/s. This can be set in the limits of the normal print speed.

Press key  to arrive at the next menu item.

ZP adjustment
0.80

Zero point adjustment:

Indication of value in 1/100 mm.

After replacing the printhead - the print cannot be continued at the same position on the label, the difference can be corrected.



NOTICE!

The value for zero point adjustment is set ex works. After replacing the printhead, only service personnel are allowed to set this value anew.

7.9 Main menu

After switching on the control unit, the display shows the following:

```
SPE 107-12 KC
16/11/07 14:35
```

The first line of main menu indicates used model type.
The second line indicates current date and time.

Press key for display the following:

```
SPE 107-12 KC
V1.49b
```

The second line of display indicates version number of firmware.
After a short time the indication of display returns automatically to main menu.

Press key once more for display the following:

```
SPE 107-12 KC
Build 0003
```

Indication of software Build version.

Press key once more for display the following:

```
SPE 107-12 KC
Sep 29 2007
```

Indication of firmware creation date.

Press key once more for display the following:

```
SPE 107-12 KC
13:51:13
```

Indication of firmware creation time.

Press key once more for display the following:

```
SPE 107-12 KC
B-Font V5.01
```

Indication of font version of bitmap fonts.

Press key once more for display the following:

```
SPE 107-12 KC
V-Font V6.01
```

Indication of font version of vector fonts.

Press key once more for display the following:

```
SPE 107-12 KC
FPGA P:02 I:01
```

Indication of version numbers of both FPGA
(P = printhead; I = I/O)

Press key once more for display the following:

```
SPE 107-12 KC
BOOT-SW V1.4d
```

Indication of boot software version number.

Press key once more for display the following:

```
SPE 107-12 KC
4 MB FLASH
```

Indication of memory space of FLASH in MB.

8 Options

8.1 Ribbon save

The menu item ribbon save is only displayed if the print module recognizes the option by the ribbon save photocell when switching on the print module.

Ribbon save = maximum utilisation of transfer ribbon



The above example shows that the consumption of transfer ribbon is much lower when using the ribbon save option.

Press key **F** to access the function menu.

Press key  as long as you arrive at the 'Ribbon save' menu.

Press key  to select the menu.

Press key  so switch the ribbon savings function On or Off.

Function Menu
Ribbon save

8.2 Network

Press key **F** to access the function menu.

Press key  as long as you arrive at the 'Network' menu.

Function Menu
Network

This menu item can only be selected if a network card is recognised at switching on the print module, otherwise a message appears that the option is not available.

For more information, please see the separate manual.

8.3 Scanner

Press key **F** to access the function menu.

Press key  as long as you arrive at the 'Scanner' menu.

Press key  to select the menu.

```
Function Menu
Scanner
```

```
Mode NoRd FLti
  1   1   1
```

Mode:

- 0 Off
- 1 Mode 1 (data comparison)
i.e. bar code data which was read by the scanner is compared with the printed data.
- 2 Mode 2 (check readability)
i.e. it is only checked if the scanner can read the printed bar codes.

NoRd = Non readables:

Indication of number of successive non readables, i.e. when the print module indicates an error message.

Value range: 1 - 9

1 = the print module stops at the first label which cannot be read from the scanner and shows an error message.

VEtik = Label feeding:

In many cases it is impossible to position the scanner directly at the printhead, and therefore with this setting a feeding can be set

Value range: 1 - 5

The illustration below clarifies the meaning of this parameter.

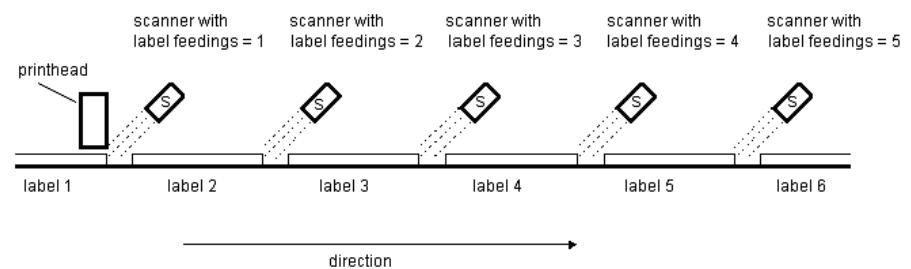

Press key  to arrive at the next menu item.

```
Scanner Type
```

Scanner type:

Selection of the connected scanner type.

For more information about the different scanner models, please contact our sales department.

Press key  to arrive at the next menu item.

```
Scanner-Setup
Start
```

Scanner setup:

Positioning of scanner. First of all, the scanner must be connected, the appropriate scanner must be selected in the scanner type menu, the interface must be activated in the interface parameter menu and the interface parameters must be set correctly.

Scan Offset (mm)
0.2

Press key  to arrive at the next menu item.

Scanner offset:

Indication of value at which the label is moved so the scanner can read data onto the label.

Press key  to arrive at the next menu item.

Scan Length (mm)
0.0 Auto

Scanner length:

If this parameter is set to 0 (AUTO), the switch on and off position of scanner is calculated by means of position and height of bar code onto the label.

If the parameter Scan Length is not 0, so this defines the length of scan sector. The start of scan sector is then set by the parameter Scan Offset. The following drawing shows the meaning of parameter.

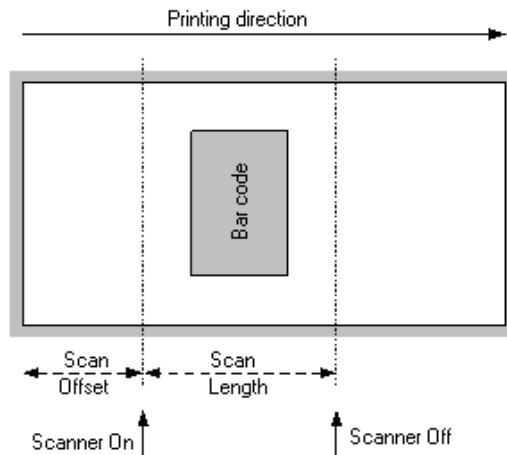

Figure 22

Press key  to arrive at the next menu item.

COM2 Baud P D S
0 9600 N 8 2

Interface:

In order to use a scanner, the COM interface must be set to 1.

For more information, please see the separate manual.

9 Memory Card

This front side of control unit is equipped with two memory card slots. By means of this memory card you can permanently save via interface graphics, text, label data or information from database.

Insertion and removal of memory card

Insert memory card with contact side forwards to the slot that was planned for it. Take care that the memory card engaged and the marking is on the left side (see illustration).

To take the memory card out of device A you have to press the upper ejector knob, to take out the card of device B press the lower one.

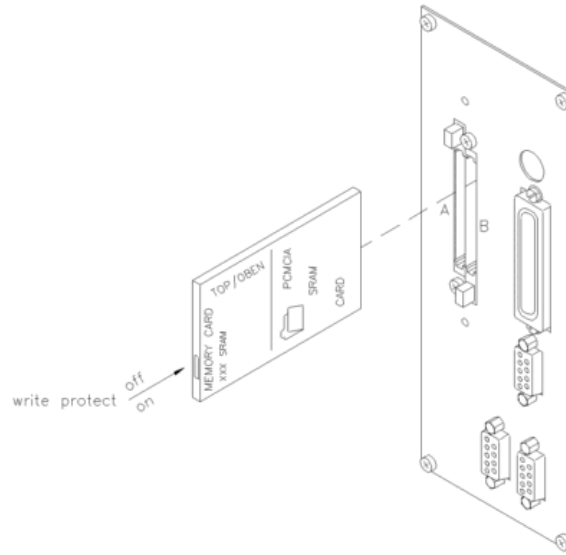

Figure 23

File and/or directory name

```
□→ SCREWS <
A:\
```

```
□→ screw04.prn
A:\SCREWS
```

The print module handles your memory card as a DOS compatible file system.

After formatting the memory card the STANDARD directory is automatically available. After switching on the print module or inserting the memory card, this directory is the current one. The directories are displayed with capital letters and the '<' sign. The indication of single files is effected in small letters.

The first line of the display shows the directory in capital letters res. the selected file, the second line shows the currently selected device with the corresponding path indication.

Key assignment

Press key  to indicate the saved labels onto the memory card.



Press key  to enter the memory card menu.

Press key  to arrive at the next menu item.

Press key  to return to the previous menu item.

Press key  to select a menu and/or to confirm a query.

Press key  to change between drive A and B inside a selected function.



Press key  and  to browse the contents of the current directory.

Press key  and  to change to the indicated directory.

Selecting label

Keys: 

```
→label01      0
A: \STANDARD\
```

Press key  and  to select the desired label in STANDARD directory.

Press key  to select the label.

Select the number of labels which you want to print

```
Start print
No.label: 12345
```

Press key  to start the print order.

After finishing the print order the display shows again the main menu.

**NOTICE!**

It is NOT possible to change the directory. Enter the menu 'Change dir' to change the directory.

Loading file from memory cardKeys: , 

```
MC-Functions
Load file
```

Press key  to select the 'Load file' menu item.



```
→<STANDARD> 0
A:\
```

Select the file you want to load and confirm the selection with key .

The loaded label is now in the printer internal storage and after the loading procedure the display shows the main menu.

Saving label onto memory cardKeys: , , 

```
MC-Functions
Save label
```

Press key  to select the 'Save label' menu item.Select the directory and/or label you want to save and confirm the selection with key .

```
File exists
Overwrite?
```

Confirm the query with  and the label will be saved.

After the saving procedure the display shows again the main menu.

Saving configurationKeys: , , , 

```
MC-Functions
Save config.
```

Press key  to select the 'Save configuration' menu item.

As standard, the proposed file name is config.cfg. This name can be changed by the user. In this file the printer parameters are saved which are not saved permanent in the internal Flash.

Press key  to start the saving procedure.

After the saving procedure, the display shows again the main menu.

Changing directory/drive



Keys: , , , , 



```
MC-Functions
Change directory
```

Press key  to select the 'Change directory' menu item.

```
←<.> M
A:\STANDARD\
```

The lower line of display shows the directory which is selected at the moment.

Press key  and  to change the directory in the upper line.

Press key  and  to show all available directories.

Press key  to confirm the selected directory.

After changing the directory the display shows again the main menu.

Deleting file from memory card

Keys: , , , , , 

```
MC-Functions
Delete file
```

Press key  to select the 'Delete file' menu item.

```
x<.> M
A:\STANDARD
```

Select directory and/or label you want to delete and confirm the selection with key .

The selected label is deleted from the memory card.

After the deleting procedure the display shows again the first menu item 'Load file'.

Formatting memory card

Keys: , , , , , 

```
MC-Functions
Format MC
```

Press key  to select the 'Format' menu item.

```
Format A:
```

Press key  to confirm the selection and the procedure is started.

When formatting the memory card the STANDARD directory is automatically created.

After the formatting procedure the display shows again the 'Load file' menu item.

Copying memory card

Keys: , , , , , , , 

```
MC-Functions
Copy MC
```

Press key  to select the 'Copy' menu item.

Press key  to select the copy function.
Drive A to A, A to B, B to A or B to B.

```
Copy MC   A:->B:
Ins. Src.+Dest.
```

Insert source and destination card and press key  to confirm the selection. The content of the source card is transferred to the destination card.



NOTICE!

When copying from A to A and B to B, please observe that the memory cards have the same storage capacity.

When copying from A to A res. B to B first of all the query regarding the destination card appears on the display.

Insert card and confirm the query. If the content of the card is loaded into the printer-internal memory, a prompt appears to insert the destination card.



NOTICE!

Depending on the storage capacity of memory card, this procedure is to be repeated.

After the copying procedure the display shows again the 'Load file' menu item.

Indication of free memory space

Keys: , , , , , , , 

```
MC-Functions
Free memory
```

Press key  to select the 'Free memory' menu item.

```
Free memory
A: 253920 KB
```

The still available memory space onto memory card is indicated.

Press key  to display again the 'Load file' menu item.

10 Maintenance and cleaning



DANGER!

Risk of death by electric shock!

⇒ Disconnect the print module from power supply before performing any maintenance work.



NOTICE!

When cleaning the label printer, personal protective equipment such as safety goggles and gloves are recommended.

Maintenance schedule

Maintenance task	Frequency
General cleaning (see section 10.1, on page 70).	As necessary.
Cleaning transfer ribbon drawing roller (see section 10.2, page 71).	Each time the transfer ribbon is changed or when the printout is adversely affected.
Cleaning print roller (see section 10.3, on page 71).	Each time the label roll is changed or when the printout and label transport are adversely affected.
Cleaning printhead (see section 10.4, on page 72).	<p>Direct thermal printing: Each time the label roll is changed.</p> <p>Thermal transfer printing: Each time the transfer ribbon is changed or when the printout is adversely affected.</p>
Cleaning label photocell (see section 10.5, on page 73).	When exchanging the label roll.
Replacing printhead (see section 10.6, on page 74).	When errors in the printout occur.



NOTICE!

The handling instructions for the use of Isopropanol (IPA) must be observed. In the case of skin or eye contact, immediately wash off the fluid thoroughly with running water. If the irritation persists, consult a doctor. Ensure good ventilation.

**WARNING!**

Risk of fire by easily inflammable label soluble!

- ⇒ When using label soluble, dust must be completely removed from the print module and cleaned.

10.1 General cleaning

**CAUTION!**

Abrasive cleaning agents can damage the print module!

- ⇒ Do not use abrasives or solvents to clean the outer surface of the print module.
- ⇒ Remove dust and paper fuzz in the printing area with a soft brush or vacuum cleaner.
- ⇒ Clean outer surfaces with an all-purpose cleaner.

10.2 Cleaning the Transfer Ribbon Drawing Roller

A soiled print roll can lead to reduced print quality and can affect transport of material.

1. Open cover of printing system.
2. Remove labels and transfer ribbon from the printing system.
3. Remove deposits with roller cleaner and a soft cloth.
4. If the roller appears damaged, replace it.

10.3 Cleaning the print roller

A soiled print roll can lead to reduced print quality and can affect transport of material.

**CAUTION!**

Print roller can be damaged!

⇒ Do not use sharp or hard objects to clean the print roller.

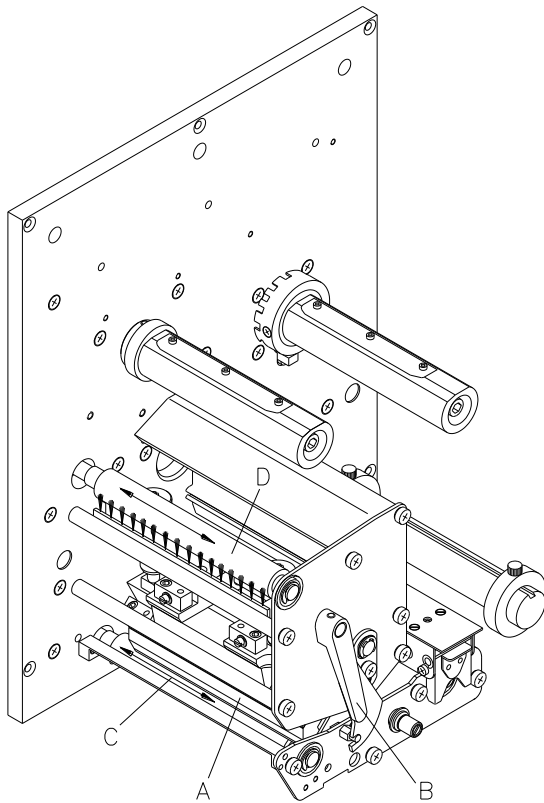

1. Open cover of print module.
2. Turn red lever (B) counter clockwise to lift up the printhead (A).
3. Remove labels and transfer ribbon from the print module.
4. Remove deposits with roller cleaner and a soft cloth.
5. Turn the roller (C) manually step by step to clean the complete roller (only possible when print module is switched off, as otherwise the step motor is full of power and the roller is kept in its position).

Figure 24

10.4 Cleaning the printhead

Printing can cause accumulation of dirt at printhead e.g. by colour particles of transfer ribbon, and therefore it is necessary to clean the printhead in regular periods depending on operating hours, environmental effects such as dust etc.



CAUTION!

Printhead can be damaged!

- ⇒ Do not use sharp or hard objects to clean the printhead.
- ⇒ Do not touch protective glass layer of the printhead.

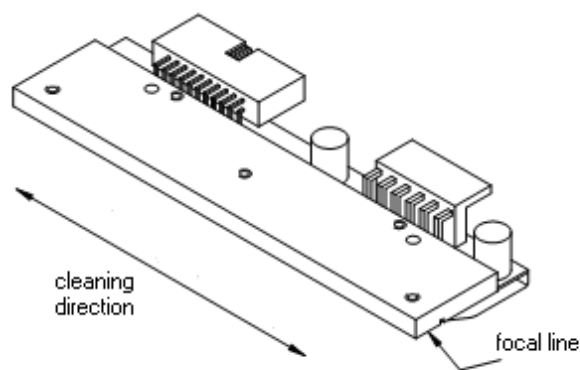

Figure 25

1. Open cover of print module.
2. Turn red lever (B, in Figure 24) counter clockwise to lift up the printhead.
3. Remove labels and transfer ribbon from the print module.
4. Clean printhead surface with special cleaning pen or a cotton swab dipped in pure alcohol.
5. Allow printhead to dry for 2-3 minutes before commissioning the print module.

10.5 Cleaning the label photocell



CAUTION!

Label photocell can be damaged!

⇒ Do not use sharp or hard objects or solvents to clean the label photocell.

The label photocell can become dirtied with paper dust and this can adversely affect label detection.

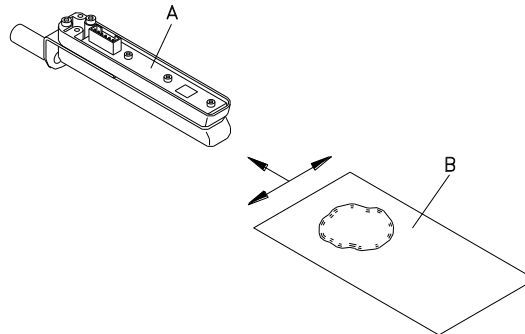

Figure 26

1. Open cover of print module.
2. Turn red lever (B, in Figure 24) counter clockwise to lift up the printhead.
3. Remove labels and transfer ribbon from the print module.
4. Blow out the photocell (A) with pressure gas spray. Observe strictly the instructions on the spray can!
5. Clean the label photocell (A) additionally with a cleaning card (B) before soaked in pure alcohol. Move the cleaning card from one side to the other (see illustration).
6. Reload labels and transfer ribbon (see chapter 5 Loading media, on page 31).

10.6 Replacing the printhead (general)

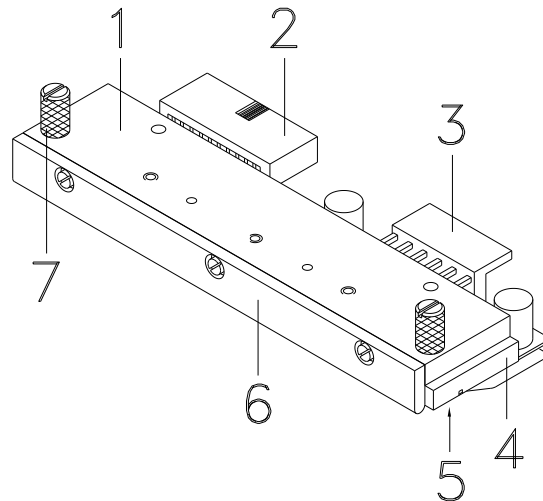

Figure 27

- 1 Head plate
- 2 Plug connection signal
- 3 Plug connection tension
- 4 Printhead
- 5 Focal line
- 6 Guiding
- 7 Knurled screw



CAUTION!

The printhead can be damaged by static electricity discharges and impacts!

- ⇒ Set up print module on a grounded, conductive surface.
- ⇒ Ground your body, e.g. by wearing a grounded wristband.
- ⇒ Do not touch contacts on the plug connections (2, 3).
- ⇒ Do not touch printing line (5) with hard objects or your hands.

10.7 Replacing FlatType printhead

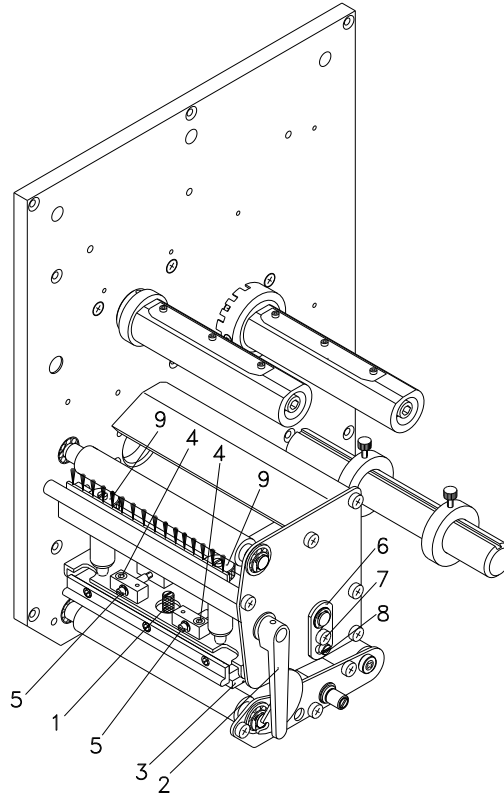

Figure 28

Removing the printhead

1. Remove labels and transfer ribbon from the print module.
2. When printhead is closed, loosen the knurled screws (1).
3. Turn red lever (2) counter clockwise to lift up the printhead.
4. If the printhead (3) is not disengaged on the pressure roller, continue loosen the knurled screws (1).
5. Remove the printhead carefully to the front until you can reach the plug connections.
6. Remove plug connections and then remove printhead (3).

Installing the printhead

1. Attach plug connections.
2. Position printhead in printhead mounting bracket in such a way that the pins are secured in the corresponding holes in the head plate.
3. Lightly keep printhead mounting bracket on the printer roller with one finger and check for correct positioning of the printhead.
4. Screw in screw (4) and tighten it.
5. Reload labels and transfer ribbon (see chapter 5 Loading media, on page 31).
6. Check resistance value on the type plate of printhead and if necessary change the value in the menu 'Service functions/heater resistance'.

10.8 Adjusting FlatType printhead

Parallelism

An important characteristic for a high quality print is the parallelism of the focal line of the thermal printhead to the pressure roll. Because of the fact that the position of focal line of the printhead depends on fluctuations caused by production, it is necessary to adjust the parallelism.

1. Loosen the screws (4, Figure 28) with a hexagon key by approx. $\frac{1}{4}$ rotations.
2. Adjust the parallelism with the adjusting screws (5, Figure 28).
Clockwise = printhead moves backwards
Counter clockwise = printhead moves forwards
3. Adjust the parallelism as long as the printing result comes up to your full expectation.
4. Tighten again screws (4, Figure 28).
5. Start a print order with approx. 10 labels and control the correct passage of transfer ribbon.

Pressure balance right/left

After adjusting parallelism and no even strong pressure exists over the complete print width, by means of a plate (6) you can set the balance as follows:

1. Loosen screw (7, Figure 28) with a screwdriver by approx. $\frac{1}{4}$ rotations.
2. In order to achieve a pressure balance, turn the excentric bolt (8, Figure 28) as long as the printing result comes up to your full expectation.
3. Tighten again screw (7, Figure 28).
4. Start a print order with approx. 10 labels and control the correct passage of transfer ribbon.

Pressure

Increasing the head contact pressure leads to an improvement of the print image density on the corresponding side and to a shifting of the ribbon feed path in the corresponding direction.

**CAUTION!**

Damage of printhead by unequal use!

⇒ Change factory settings only in exceptional cases.

The selection of the smallest value can optimise the life cycle of printhead.

1. Turn pressure screws (9, Figure 28) to change the pressure of printhead.
2. Turning the pressure screws (9, Figure 28) as far as they will go in clockwise direction results in a pressure increase of 10N in contrast to the factory setting.
3. Turning the pressure screws (9, Figure 28) exactly one rotation from the right stop position counter clockwise results in the factory settings.

**NOTICE!**

It is importantly that the knurled button which is coated with protective lacquer is not removed from the pressure screw as otherwise the above mentioned settings are faulty.

10.9 Replacing CornerType printhead

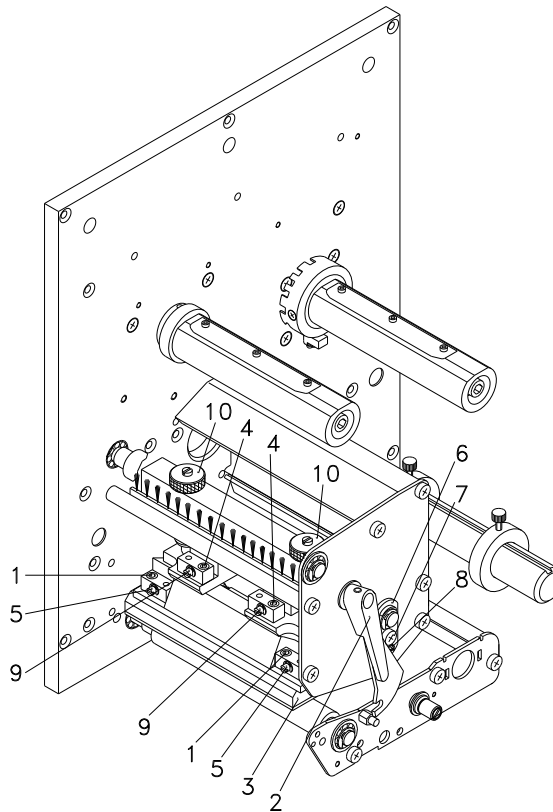

Figure 29

Removing the printhead

1. Remove labels and transfer ribbon from the print module.
2. When printhead is closed, loosen the knurled screws (1).
3. Turn red lever (2) counter clockwise to lift up the printhead.
4. If the printhead (3) is not disengaged on the pressure roller, continue loosen the knurled screws (1).
5. Remove the printhead carefully to the front until you can reach the plug connections.
6. Remove plug connections and then remove printhead (3).

Installing the printhead

1. Attach plug connections.
2. Position printhead in printhead mounting bracket in such a way that the pins are secured in the corresponding holes in the head plate.
3. Lightly keep printhead mounting bracket on the printer roller with one finger and check for correct positioning of the printhead.
4. Screw in screw (1) and tighten it.
5. Reload labels and transfer ribbon (see chapter 5 Loading media, on page 31).
6. Check resistance value on the type plate of printhead and if necessary change the value in the menu 'Service functions/heater resistance'.

10.10 Adjusting CornerType printhead

Parallelism

An important characteristic for a high quality print is the parallelism of the focal line of the thermal printhead to the pressure roll. Because of the fact that the position of focal line of the printhead depends on fluctuations caused by production, it is necessary to adjust the parallelism.

The form of the CornerType printhead needs the setting of parallelism in direction of the adjusting angle and in horizontal position. It needs a little bit of experience to know in which direction you have to adjust the printhead to receive a high quality printing.

1. Loosen the screws (1 or 4, Figure 29) with a hexagon key by approx. $\frac{1}{4}$ rotations.
2. Adjust the parallelism with the adjusting screws (5 or 9, Figure 29).
Clockwise = printhead moves backwards
Counter clockwise = printhead moves forwards
3. Adjust the parallelism as long as the printing result comes up to your full expectation.
4. Tighten again screws (1 or 4, Figure 29).
5. Start a print order with approx. 10 labels and control the correct passage of transfer ribbon.

Pressure balance right/left

After adjusting parallelism and no even strong pressure exists over the complete print width, by means of a plate (6) you can set the balance as follows:

1. Loosen screw (7, Figure 29) with a screwdriver by approx. $\frac{1}{4}$ rotations.
2. In order to achieve a pressure balance, turn the excentric bolt (8, Figure 29) as long as the printing result comes up to your full expectation.
3. Tighten again screw (7, Figure 29).
4. Start a print order with approx. 10 labels and control the correct passage of transfer ribbon.

Pressure

Increasing the head contact pressure leads to an improvement of the print image density on the corresponding side and to a shifting of the ribbon feed path in the corresponding direction.



CAUTION!

Damage of printhead by unequal use!

⇒ Change factory settings only in exceptional cases.

The selection of the smallest value can optimise the life cycle of printhead.

1. Turn pressure screws (10, Figure 29) to change the pressure of printhead.
2. Turning the pressure screws (10, Figure 29) as far as they will go in clockwise direction results in a pressure increase of 10N in contrast to the factory setting.
3. Turning the pressure screws (10, Figure 29) exactly one rotation from the right stop position counter clockwise results in the factory settings.



NOTICE!

It is importantly that the knurled button which is coated with protective lacquer is not removed from the pressure screw as otherwise the above mentioned settings are faulty.

11 Error correction

Error message	Cause	Remedy
1 Line too high	Line rises up completely or partly over the upper edge of label.	Move line down (increase Y value). Check rotation and font.
2 Line too low	Line rises up completely or partly over the bottom edge of label.	Move line up (reduce Y value). Check rotation and font.
3 Character set	One res. several characters of the text is res. are not available in the selected font.	Change text. Change font.
4 Unknown code type	Selected code is not available.	Check code type.
5 Invalid position	Selected position is not available.	Check position.
6 CV font	Selected font is not available.	Check font.
7 Vector font	Selected font is not available.	Check font.
8 Measuring label	While measuring no label was found. Set label length is too large.	Check label length and if labels are inserted correctly. Restart measuring anew.
9 No label found	No label available. Soiled label photocell. Labels not inserted correctly.	Insert new label roll. Check if labels are inserted correctly. Clean the label photocell.
10 No ribbon	During the print order the ribbon roll becomes empty. Defect at the transfer ribbon photocell.	Change transfer ribbon. Check transfer ribbon photocell (service functions).
11 COM FRAMING	Stop bit error.	Check stop bits. Check baud rate. Check cable (printer and PC).
12 COM PARITY	Parity error.	Check parity. Check baud rate. Check cable (printer and PC).
13 COM OVERRUN	Loss of data at serial interface (RS-232).	Check baud rate. Check cable (printer and PC).

Error message	Cause	Remedy
14 Field numer	Received line number is invalid at RS-232 and parallel interface.	Check sent data. Check connection PC - printer.
15 Length mask	Invalid length of received mask statement.	Check sent data. Check connection PC - printer.
16 Unknown mask	Transferred mask statement is invalid.	Check sent data. Check connection PC - printer.
17 Missing ETB	No end of data found.	Check sent data. Check connection PC - printer.
18 Invalid character	One res. several characters of the text is res. are not available in the selected font.	Change text. Change font.
19 Invalid statement	Unknown transferred data record.	Check sent data. Check connection PC - printer.
20 Invalid check digit	For check digit control the entered res. received check digit is wrong.	Calculate check digit anew. Check code data.
21 Invalid SC number	Selected SC factor is invalid for EAN res. UPC.	Check SC factor.
22 Invalid number of digits	Entered digits for EAN res. UPC are invalid < 12; > 13.	Check number of digits.
23 Check digit calculation	Selected check digit calculation is not available in the bar code.	Check calculation of check digit. Check bar code type.
24 Invalid extension	Selected zoom factor is not available.	Check zoom factor.
25 Offset sign	Entered sign is not available.	Check offset value.
26 Offset value	Entered offset value is invalid.	Check offset value.
27 Printhead temperature	Printhead temperature is too high. Defective printhead sensing device.	Reduce contrast. Change printhead.
28 Cutter error	With cut an error occurred. Paper jam.	Check label run. Check cutter run.
29 Invalid parameter	Entered data do not correspond to the characters allowed from the application identifier.	Check code data.

Error message	Cause	Remedy
30 Application Identifier	Selected application identifier is not available in GS1-128.	Check code data.
31 HIBC definition	F Missing HIBC system sign. Missing primary code.	Check definition of HIBC code.
32 System clock	Real Time Clock function is selected but the battery is empty. Defective RTC.	Change battery. Change RTC component.
33 No CF interface	Interrupted connection CPU - CF card. Defective CF card interface.	Check connection CPU - CF card interface. Check CF card interface.
34 No print memory	No print CF found.	Check CF assembly on CPU.
35 Printhead open	At start of a print order the printhead is open.	Close the printhead and start print order anew.
36 BCD invalid format	BCD error Invalid format for the calculation of Euro variable.	Check entered format.
37 BCD overflow	BCD error Invalid format for the calculation of Euro variable.	Check entered format.
38 BCD division	BCD error Invalid format for the calculation of Euro variable.	Check entered format.
39 FLASH ERROR	Flash component error.	Run a software update. Change CPU.
40 Length command	Invalid length of the received command statement.	Check data sent. Check connection PC - printer.
41 No drive	CF card not found / not correctly inserted.	Insert CF card correctly.
42 Drive error	Impossible to read CF card (faulty).	Check CF card, if necessary change it.
43 Not formatted	CF Card not formatted.	Format CF card.
44 Delete current directory	Attempt to delete the actual directory.	Change directory.
45 Path too long	Too long indication of path.	Indicate a shorter path.

Error message	Cause	Remedy
46 Drive write-protected	Memory card is write-protected.	Deactivate write protection.
47 Directory not file	Attempt to indicate a directory as file name.	Correct your entry.
48 File already open	Attempt to change a file during an access is active.	Select another file.
49 No file/directory	File does not exist on CF card.	Check file name.
50 Invalid file name	File name contains invalid characters.	Correct entry of name, remove special characters.
51 Internal file error	Internal file system error.	Please contact your distributor.
52 Root full	The max. number (64) of main directory entries is reached.	Delete at least one main directory entry and create subdirectories.
53 Drive full	Maximum CF capacity is reached.	Use new CF Card, delete no longer required files.
54 File/directory exists	The selected file/directory already exists.	Check name, select a different name.
55 File too large	During copying procedure not enough memory space onto target drive available.	Use a larger target card.
56 No update file	Errors in update file of firmware.	Start update file anew.
57 Invalid graphic file	The selected file does not contain graphic data.	Check file name.
58 Directory not empty	Attempt to delete a not empty directory.	Delete all files and sub-directories in the desired directory.
59 No interface	No CF card drive found.	Check connection of CF card drive. Contact your distributor
60 No CF card	No CF card is inserted.	Insert CF card in the slot.
61 Webserver error	Error at start of web server.	Please contact your distributor.
62 Wrong FPGA	The direct printing system is equipped with the wrong FPGA.	Please contact your distributor.
63 End position	The label length is too long. The number of labels per cycle is too much.	Check label length res. the number of labels per cycle.

Error message	Cause	Remedy
64 Zero point	Defective photocell.	Change photocell.
65 Compressed air	Pressure air is not connected.	Check pressure air.
66 External releaser	External print release signal is missing.	Check input signal.
67 Row too long	Wrong definition of column width res. number of columns.	Reduce the column width res. correct the number of columns.
68 Scanner	The connected bar code scanner signals a device error.	Check the connection scanner/printer. Check scanner (dirty).
69 Scanner NoRead	Bad print quality. Printhead completely soiled or defective. Print speed too high.	Increase contrast. Clean printhead or exchange (if necessary). Reduce print speed.
70 Scanner data	Scanned data does not correspond to the data which is to print.	Exchange printhead.
71 Invalid page	As page number either 0 or a number > 9 is selected.	Select a number between 1 and 9.
72 Page selection	A page which is not available is selected.	Check the defined pages.
73 Page not defined	The page is not defined.	Check the print definition.
74 Format user guiding	Wrong format for customised entry.	Check the format string.
75 Format date/time	Wrong format for date/time.	Check the format string.
76 Hotstart CF	No CF card found.	If option hotstart was activated, a CF card must be inserted. Switch off the printer before inserting the memory card.
77 Flip/Rotate	Selection of print of several columns and also mirror/rotate.	It is only possible to select one of both functions.
78 System file	Loading of temporary hotstart files.	Not possible.
79 Shift variable	Faulty definition of shift times (overlapping times).	Check definition of shift times.
80 GS1 Databar	General GS1 Databar error.	Check definition and parameter of GS1 Databar code.
81 IGP error	Protocol error IGP.	Check sent data.

Error message	Cause	Remedy
82 Time generation	Printing creation was still active at print start.	Reduce print speed. Use printers' output signal for synchronisation. Use bitmap fonts to reduce generating time.
83 Transport protection	Both DPM position sensors (start/end) are active.	Displace zero point sensor Check sensors in service functions menu
84 No font data	Font and web data is missing.	Run a software update.
85 No layout ID	Label ID definition is missing.	Define label ID onto the label.
86 Layout ID	Scanned data does not correspond to defined ID.	Wrong label loaded from CF card.
87 RFID no label	RFID unit cannot recognise a label.	Displace RFID unit or use an offset.
88 RFID verify	Error while checking programmed data.	Faulty RFID label. Check RFID definitions
89 RFID timeout	Error at programming the RFID label.	Label positioning. Faulty label.
90 RFID data	Faulty or incomplete definition of RFID data.	Check RFID data definitions.
91 RFID tag type	Definition of label data does not correspond with the used label.	Check storage partitioning of used label type
92 RFID lock	Error at programming the RFID label (locked fields).	Check RFID data definitions. Label was already programmed.
93 RFID programming	Error at programming the RFID label.	Check RFID definitions.
94 Scanner timeout	The scanner could not read the bar code within the set timeout time.	
	Defective printhead. Wrinkles in transfer ribbon. Scanner wrong positioned. Timeout time too short.	Check printhead. Check transfer ribbon. Position scanner correctly, corresponding to the set feeding. Select longer timeout time.

Error message	Cause	Remedy
95 Scanner layout difference	Scanner data does not correspond to bar code data.	Check adjustment of scanner. Check scanner settings / connection.
96 COM break	Serial interface error.	Check settings for serial data transmission as well as cable (printer-PC).
97 COM general	Serial interface error.	Check settings for serial data transmission as well as cable (printer-PC).
98 No software printhead FPGA	No printhead-FPGA data available.	Please contact your responsible distributor.
99 Load software printhead FPGA	Error when programming printhead-FPGA.	Please contact your responsible distributor.
100 Upper position	Sensor signal up is missing (option APL 100).	Check input signals / compressed-air supply.
101 Lower position	Sensor signal down is missing (option APL 100).	Check input signals / compressed-air supply.
102 Vacuum plate empty	Sensor does not recognise a label at vacuum plate (option APL 100).	Check input signals / compressed-air supply.
103 Start signal	Print order is active but device not ready to process it.	Check start signal.
104 No print data	Print data outside the defined label. Selection of wrong module type (design software).	Check selected module type. Check selection of left/right version.
105 Printhead	No original printhead is used.	Check the used printhead. Contact your distributor.
106 Invalid Tag type	Wrong Tag type. Tag data do not match the Tag type in the printer.	Adapt data or use the correct Tag type.
107 RFID invalid	RFID module is not activated. No RFID data can be processed.	Activate RFID module or remove RFID data from label data.
108 GS1-128 invalid	Transferred GS1-128 bar code is invalid.	Verify bar code data (see GS1-128 bar code specification).
109 EPC parameter	Error at EPC calculation.	Verify data (see EPC specification).

Error message	Cause	Remedy
110 Housing open	When starting the print order the housing cover is not closed.	Close the housing cover and start the print order anew.
111 EAN.UCC code	Transferred EAN.UCC code is invalid.	Verify bar code data (see corresponding specification).
112 Print carriage	Printing carriage does not move.	Check gear belt (possibly broken).
113 Applicator error	Error while using applicator.	Check applicator.
114 Left position	Left final position switch is not in correct position.	Check LEFT final position switch for correct function and position. Check function of pneumatics for cross traverse.
115 Right position	Right final position switch is not in correct position.	Check RIGHT final position switch for correct function and position. Check function of pneumatics for cross traverse.
116 Print position	The print position is not correct.	Check TOP and RIGHT final position switch for correct function and position. Check pneumatics for function
117 XML parameter	The parameters in the XML file are not correct.	Please contact your responsible distributor.
118 Invalid variable	Transferred variable is invalid with customized entry.	Select correct variable without customized entry and transfer it.
119 No ribbon	During the print order the ribbon roll becomes empty. Defect at the transfer ribbon photocell.	Change transfer ribbon. Check transfer ribbon photocell (service functions).
120 Wrong directory	Invalid target directory when copying.	Target directory must not be within the source directory. Check target directory.
121 No label found	No label found at the rear printhead (DuoPrint). Soiled label photocell. Labels not inserted correctly.	Insert new label roll. Clean the label photocell. Check if labels are inserted correctly.
122 IP occupied	The IP address was already assigned.	Assign a new IP address.

Error message	Cause	Remedy
123 Print asynchronous	<p>The label photocell do not work in the order as it is expected according to print data.</p> <p>The settings of the photocell are not correct.</p> <p>Settings of label size and gap size are not correct.</p> <p>No label found at the rear printhead.</p> <p>Soiled label photocell.</p> <p>Labels not inserted correctly.</p>	<p>Check label size and gap size.</p> <p>Check label photocell settings.</p> <p>Check correct loading of label material.</p> <p>Insert new label roll.</p> <p>Clean the label photocell.</p> <p>Check if labels are inserted correctly.</p>
124 Print too slow	The print speed is too slow.	Increase the speed of the customers' machine.
125 DMA send buffer	Communication problem HMI.	Restart the printer.
126 UID conflict	Configuration RFID programming faulty.	Run RFID initialising.
127 Module not found	RFID module not available.	<p>Check the RFID module connection.</p> <p>Please contact your responsible distributor.</p>
128 No release signal	No print release by higher-level control (customer machine).	Activate release signal at the higher-level control.
129 Wrong firmware	Firmware does not match the used printer type.	<p>Use firmware that fits to the printer type.</p> <p>Please contact your responsible distributor.</p>
130 Language missing	Language file for the set printer language is not available.	Please contact your responsible distributor.
131 Wrong material	Label material does not fit to printing data.	User label material with suitable label and/or gap length.
132 Invalid mark-up tag	Invalid mark-up formatting characters in text.	Correct the formatting characters in the text.
133 Script not found	LUA script file not found.	Check the file name.

Error message	Cause	Remedy
134 Script failure	LUA script is incorrect.	Check the script.
135 Script user error	Error in LUA script user input.	Correct the input value.
136 No reprint available	No label data for reprinting available.	Send new label data to the printer.
137 Printhead short circuit	Electrical short at the printhead.	Check the used printhead. Please contact your distributor.
138 Too little ribbon	Transfer ribbon ends.	Change transfer ribbon.

12 Additional information

12.1 Column printing

With this print module several columns can be printed, i.e. the information of one column can be printed several times (depending on its width) on a label. Caused by this the use of the complete print width is possible and the generating time is enormously reduced.

For example 4 columns with a width of 25 mm or 2 columns with a width of 50 mm can be printed onto a label with a width of 100 mm. Please note that the first label is always the one with the largest x coordinate, i.e. it has the largest distance to the printhead.

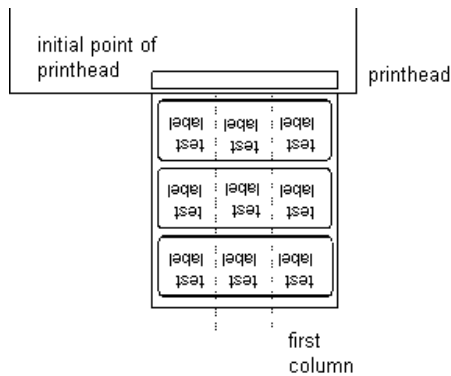



Setting the print of several columns

Press key **F** to change to the function menu.



Press key  as long as to the 'Label layout' menu.

Press key  to confirm the selection.

Press key  as long as the menu item (see illustration) appears.

Press key  and  to set the label width. As column width the width of one label is entered, e.g. 20.0 mm.

Press key  and  to enter the number of columns.

Press keys  and  to change the number of columns, e.g. 4 columns at a label width of 20.0 mm.

Press key  to start a print with indication of number of labels and number of lines. The number of labels corresponds to the number of labels that are to print.

e.g. columns: 3, items: 4



The first four labels were printed but not label 5 and 6.

12.2 Password

Example 1: The supervisor programs a Memory Card directly with the module. He stores 10 different labels. As well he adjusts the print parameters, like contrast, speed, etc. to the corresponding values. The user is only supposed to read the labels from memory card and to print them. Therefore the supervisor blocks the function menu and the entry function by a password.

Example 2: The print module is connected to a PC. The user is only supposed to take the labels dispensed by the print module and stick them on. To prevent, that the labels or the print module set-up will not be changed, the supervisor blocks all print module functions (e.g. function menu, entry menu, etc.) by a password.

Example 3: The user has to change several texts before printing. It is not allowed to change any masks (fonts, position, etc.). Therefore the supervisor blocks the entry of mask and the function menu. By this means the user indeed can print labels, but the print module set-up and the masks of the labels can't be changed.

To receive a most flexible password protection, the print module functions will be divided into several function groups:

1. Function menu: In the function menu the print parameters can be changed (contrast, speed, mode, ...). The password protection prevents modifications at the print settings.

2. Memory Card: With the functions of your Memory Card labels can be stored, loaded,
Here the password protection has to separate, if none or only reading functions are allowed.

3. Print functions: With key **quant** a print can be produced. In case the print module is connected to a PC, it can be useful, that the user is not able to produce a print manually. So the password protection prevents that prints can be produced manually.

Because of these different function groups the password protection is very flexible. The print module can be adjusted best to its actual order, as only certain functions are blocked.

Define password

In case no password is defined res. the password protection is not activated, all functions can be used. In the function menu you will find the menu item "Password", where the password can be entered and the password protection activated.

Press key  as long as to the 'Password' menu.

Press key  to confirm the selection.

```

Password 0000 J
F:0 MC:0 D:0

```



Meaning of abbreviations:

F Function menu
 MC Memory Card
 D Print functions

In case the password protection is active, but the function menu is not protected, the password



(4-digit number between 0000 and 9999) has to be entered first, so the above shown display appears. Now changes can be done. In the first line the user can define the password (4-digit number).

Press key  to switch to the next.

Press key  and  to activate/deactivate the password protection (yes/no).

Press key  to change to the second line.

Press key  and  to block/release individual function groups.

(Press key  and  to change from one group to the next one.)

F:	Function menu	0...open 1...locked
MC:	Memory Card	0...open 1...only reading access 2...access blocked
D:	Printer guiding	0...open 1...open 2...no manual print release

Activate blocked function:

```

Password Prot.
0000

```

In case the user wants to perform a blocked function, he has to enter the valid password first.

The entered password has to be confirmed with **E**. In case the correct password has been entered the desired function can be performed. If the entered password was invalid no error message appears but the main menu will be displayed.

12.3 Hotstart



NOTICE!

The data is saved onto CF card. Therefore the CF card is a condition for the *Hotstart* menu item.

The function hotstart contains e.g. that in case of a power failure the currently loaded label can be further processed without any loss of data.

Moreover a print order can be interrupted and to be continued after switching on the printer anew.



NOTICE!

At an active hotstart all necessary data is stored on the memory card therefore do not remove the card during operation. When removing during operation, this causes the loss of all data on the memory card.

Saving the current label

In case the hotstart function is set to on, at the start of a print order the data of the current label is saved to the corresponding directory of the memory card.

However the following conditions have to be fulfilled:

- Memory card inserted in drive A
- Memory card not write protected
- Enough free storage space onto memory card
- An error message appears in case these conditions are not fulfilled.

Saving the printer order state

At switching off the printer the state of the current print order is saved to the corresponding directory of the memory card.

However the following conditions have to be fulfilled:

- Memory card inserted in drive A
- Memory card not write protected
- Enough free storage space onto memory card

Loading a label and print order state

In case the hotstart function is set to On, at a new start of printer the saved label data and the print order state is loaded from the corresponding file on the memory card. Because of this reason a memory card has to be inserted at switching on the printer. In case it is impossible to load the data an error message appears.

Starting the print order

In case at switching off the print module a print order was active, then a print start is released automatically and the required res. actual number of printed labels is refreshed.

In case the print order was stopped at switching off the print module, it is again set to the stopped mode after switching on the print module anew.

In case a customized entry was active during switching off the print module, the window for the first customized variable is displayed.

Refreshing the variable counter

As in the intended file only the start values of the counter are saved, they are refreshed at a new start of the print order by means of the number of printed labels. Each counter is counted corresponding from its start value. Afterwards the position of the current and the next counter update are correctly set by means of the update intervals.

**NOTICE!**

Make sure that in case graphics are onto the label they have to be saved onto memory card.

12.4 Backfeed/delay

Backfeed operating modes

In continuous dispensing mode (IO dynamic continuous, IO static continuous, IO photocell continuous) no optimised backfeed is possible. Because of the fact when changing the print order, then the current label in the offset sector is already printed from the old print order.

With activated double cut no optimised backfeed is possible.

In the sector that is printed when preprint the following label, no date/time variable should be existing, because this could be refreshed before the next start impulse.

Standard

Peel off: After printing the label, it is driven into the dispensing offset and waited there, until the label was removed (photocell) or a new start signal is given (IO dynamic). Afterwards it is again backtracked to the beginning of label and then the next label is printed.

Cutter: After printing the label, it is driven into the cutter offset; the label is cut and then backtracked immediately to the beginning of label (if an operating mode with backfeed is selected). Afterwards the next label is printed, if necessary.

Tear off edge: After printing the last label of a print order it is driven into the tear-off offset and the label res. labels can be taken away. When starting a new print order, first it is backtracked again to the beginning of label and then the next label is printed.
If a following print order is available before driving into the tear-off offset, then it is not driven into tear-off offset but the following label is directly printed.

Automatic

Peel off: After printing the label it is driven into the dispensing offset and then backtracked to the beginning of label either immediately or after the set delay time. When releasing a new start signal (IO dynamic) the next label is immediately printed.

Cutter: This is the same function as for 'backfeed standard' as it is always backtracked immediately to the beginning of label.

Tear off edge: After printing the last label of a print order it is driven into the tear-off offset and then backtracked to the beginning of label either immediately or after the set delay time. When starting a new print order then the next label is immediately printed.
If a following print order is available before driving into the tear-off offset, then it is not driven into tear-off offset but the following label is directly printed.

No backfeed	Peel off:	After printing the label it is driven into the dispensing offset and there waited. When releasing a new start signal (IO dynamic) then the next label is immediately printed. Because of the fact that the label is already in the offset, the label is only printed from beginning of offset position, i.e. at the definition of label an accordingly large range must be left free at the top margin of label, because these data are otherwise not printed.
	Cutter:	This is the same function as for 'backfeed standard' as it is always backtracked after cutting immediately to the beginning of label.
	Tear off edge:	After printing the last label of a print order it is driven into the tear-off offset. When starting a new print order, the next label is immediately printed. Because of the fact that the label is already in the offset, the label is only printed from beginning of offset position, i.e. at the definition of label an accordingly large range must be left free at the top margin of label, because these data are otherwise not printed. If a following print order is available before driving into the tear-off offset, then it is not driven into tear-off offset but the following label is directly printed.
Optimised backfeed	Peel off:	After printing the label, during driving into dispensing offset the following label is 'pre-printed', if this is already available (generated). When releasing a new start signal (IO dynamic) the already 'pre-printed' label is printed to the end and when driving into the dispenser offset the following label is again 'pre-printed'. In case the following label is not yet available or at the last label of a print order, the dispenser offset is driven as until now, and then for the next label before printing the backfeed to the beginning of label is executed.
	Cutter:	After printing the label, during driving into the cutter offset the following label is 'pre-printed', if this is already available (generated). After the cut it is not backtracked but the already 'pre-printed' label is printed to the end and when driving into the cutter offset the following label is again 'pre-printed'. If the following label is not yet available or at the last label of a print order, the cutter offset is driven as until now, then cut and afterwards the backfeed to the beginning of label is executed.
	Tear off edge:	This is the same function as for 'backfeed standard' as it is only driven into the tear-off offset at the last label of a print order, if no following print order is available.

12.5 Transmission photocells

Transmission photocell normal

For this photocell type the transmitter is at the top res. the receiver at the bottom, i.e. the infra-red light is sent from the top. In this way the label detection is also from the top. This photocell type is used for standard adhesive labels with gap.

Transmission photocell inverse

For this photocell type the transmitter is at the top res. the receiver at the bottom, i.e. the infra-red light is sent from the top. The label detection is, same as for the transmission photocell normal, from the top. However, it is printed differently as for normal photocells, in the translucent place; the print module recognizes the opaque place as gap. This photocell type is used frequently when printing foils.



NOTICE!

When using transmission photocells inverse, the print module must measure a difference of 2.5 V and for reflection photocells inverse 1 V between translucent and opaque material. Otherwise the print module does not recognize a difference between label and gap (bar).

12.6 Ultrasonic photocell (option)



NOTICE!

The printer may not be equipped with the option ribbon save.

This photocell type is particularly suitable for the use of transparent labels on transparent backing paper.



NOTICE!

The ultrasonic photocell must be adjusted on the currently used label material.

Adjustment of photocell

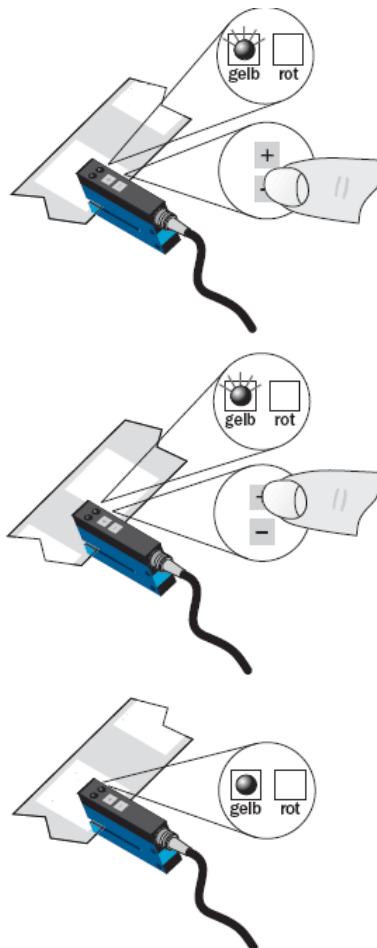

Adjustment of switching point in 'light-switching' mode:

The switching output Q is active if the backing paper is detected between the labels (gap detection).

Position the label between the active surface of the fork sensor (see arrow on sensor). With key **-** and/or **+** adjust until the switching output indicator is off.

Position the backing paper in the active area of the fork sensor. The switching output indicator (yellow) must light up again. Otherwise increase the sensitivity with **+** until the switching threshold is correctly adjusted.

If necessary, adjust the switching point slightly in the other direction.

Sensitivity setting

Slow setting:
Press key **+** and/or **-** once.
The red LED lights with each key press.

Fast setting:
Press key **+** and/or **-** permanently.
The red LED flashes after 2 seconds.

Light (L) / dark (D) switching

Press key **+** and **-** simultaneously for 6 seconds.
The yellow LED changes status and the red LED flashes slowly.
Release keys **+** and **-**.

Locking the keys

Press keys **+** and **-** simultaneously for 3 seconds to enable/disable the key lock.

Locking the keys:
The red LED goes off after 3 seconds.
Release keys **+** and **-** and the red LED lights permanently.

Unlocking the keys:
The red LED lights after 3 seconds.
Release keys **+** and **-** and the red LED goes off.

13 Environmentally-Friendly Disposal

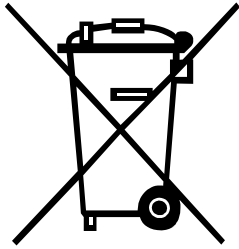

Manufacturers of B2B equipment are obliged to take back and dispose of old equipment that was manufactured after 13 August 2005. As a principle, this old equipment may not be delivered to communal collecting points. It may only be organised, used and disposed of by the manufacturer. Valentin products accordingly labelled can therefore be returned to Carl Valentin GmbH.

This way, you can be sure your old equipment will be disposed of correctly.

Carl Valentin GmbH thereby fulfils all obligations regarding timely disposal of old equipment and facilitates the smooth reselling of these products. Please understand that we can only take back equipment that is sent free of carriage charges.

Further information on the WEEE directive is available on our website www.carl-valentin.de.

14 Index

B	
Backfeed/delay	96, 97
C	
Column printing	91
Connecting print module	28
Connector pin assignment	
Control unit	7
Rear panel of mechanics	8
E	
Environmentally-friendly disposal	101
Error messages/Error corrections 81, 82, 83, 84, 85, 86, 87, 88, 89, 90	
F	
Function menu	
Device settings	46, 48
Dispenser I/O	49, 50, 51
Emulation	53
Interface	51, 52
Label layout	44, 45
Menu structure	39, 40, 41, 42
Print settings	43
Service functions	55, 56, 57
H	
Hotstart	94, 95
I	
Important notes	6
Initial operation	29
Inputs/outputs	18, 19, 20, 21, 22, 23, 24, 25
Installation	27
Instructions	5
Intended use	5, 6
K	
Keyboard	
Standard	35
Text entry/customized entry	36, 37
L	
Loading labels	
Passing mode	32
Peel off mode	31
Loading transfer ribbon	33
M	
Main menu	58
Maintenance/cleaning	
General cleaning	70
Label photocell cleaning	73

Maintenance schedule	69
Print roller cleaning	71
Printhead adjusting	76, 79, 80
Printhead cleaning	72
Printhead replacing	74, 75, 78
Ribbon drawing roller, cleaning	70
O	
Operating conditions	11, 12, 13, 14
Options	
Memory card	64, 65, 66, 67
Network	59
Ribbon save	59
P	
Password protection	92, 93
Photocells	98, 99, 100
Printhead adjusting, CornerType	
Parallelism	79
Pressure	80
Pressure balance	79
Printhead adjusting, FlatType	
Parallelism	76
Pressure	77
Pressure balance	76
Printhead, replacing	
CornerType	78
FlatType	75
S	
Safety Instructions	10
Safety notes	10
Setting up	27
Signal diagrams	26
Switching on/off print module	28
U	
Ultrasonic photocell	99, 100
W	
Warnings	10



Carl Valentin GmbH
Neckarstraße 78 – 86 u. 94 . 78056 Villingen-Schwenningen
Phone +49 7720 9712-0 . Fax +49 7720 9712-9901
info@carl-valentin.de . www.carl-valentin.de