

---

# Scantech ID Shuttle<sup>c</sup> SG-15<sup>COLOUR</sup> Price Checker



BASIC EDITION





## **User's, Installation and Configuration Manual**

---

**Scantech-ID Shuttle<sup>C</sup> SG-15<sup>Colour</sup>**



## **Copyright © 2016, Scantech-ID BV.**

This manual is copyrighted, with all rights reserved. Under the copyright laws, this manual may not, in whole or in part, be copied, photocopied, reproduced, translated or converted to any electronic medium or machine readable form without prior written consent of Scantech-ID BV.

### **Limited Warranty**

Under all circumstances this manual should be read attentively, before installing and/or using the product. In no event shall Scantech-ID BV be liable for any direct, indirect, special, consequential or incidental damages arising out of the use or inability to use this documentation or product, even if advised of the possibility of such damages. In particular, Scantech-ID BV shall not be liable for any hardware, software, or data that is stored or used with the product, including the cost of repairing, replacing or recovering the above. Scantech-ID BV reserves the right to change parts of the device at any time without preceding or direct announcement to the client.

Scantech-ID BV reserves the right to revise this manual, and to make changes in the contents without obligation to notify any person or entity of the revision or change. A serial number appears on the product. Make sure that this official registration number has not been removed. It should be used whenever servicing by Scantech-ID BV or an authorised Scantech dealer is necessary.

### **Important**

This equipment has been tested and found to comply with the limits for a Class B digital device, pursuant to EN55022, and with the limits for a class A digital device, pursuant to part 15 of the FCC rules. These limits are designed to provide reasonable protection against harmful interference when the equipment is operated in a commercial environment. This equipment generates, uses, and can radiate radio frequency energy and, if not installed and used in accordance with the user's manual, may cause harmful interference to radio communications. Operation of the equipment in a residential area is likely to cause harmful interference in which case the user will be required to correct the interference at his own expense. Any unauthorised changes or modifications to this equipment could void the user's authority to operate this equipment.

The Shuttle<sup>c</sup> is in conformity with the CE standards. Please note that a Scantech CE-marked power supply unit should be used to conform to these standards.

### **Radio and television interference**

Operation of this equipment in a residential area can cause interference with radio or television reception. This can be determined by turning the equipment off and on. The user is encouraged to try to correct the interference by one or more of the following measures:

- Re-orientate the receiving antenna
- Relocate the devices with respect to the receiver
- Move the device away from the receiver
- Plug the device into a different outlet in order to have the device and receiver on different branch circuits

If necessary, the user should consult the manufacturer, an authorised Scantech dealer or experienced radio/television technician for additional suggestions. The booklet "How to Identify and Resolve Radio-TV Interference Problems", prepared by the Federal Communications Commission, can be of help. It can be obtained from the U.S. Government Printing Office, Washington, DC 20402, Stock No. 004000003454.



# Table of contents

---

Preface.....	3
Chapter 1 Product Safety.....	11
1.1 Used conventions.....	12
1.2 Laser safety.....	12
1.3 Declaration of Conformity.....	15
1.4 Product Labelling.....	16
Chapter 2 General Description.....	17
2.1 Use of the Shuttle <sup>c</sup> .....	18
2.2 Construction of the Shuttle <sup>c</sup> .....	19
2.3 Functioning of the Shuttle <sup>c</sup> .....	20
2.4 Power Over Ethernet (PoE) .....	22
Chapter 3 Installation of the Shuttle <sup>c</sup> .....	23
3.1 Unpacking.....	24
3.2 Mounting.....	24
Chapter 4 System Integration.....	26
4.1 Software.....	27
Chapter 5 Configuring the Shuttle <sup>c</sup> .....	31
5.1 Making Connection and Login.....	32
5.2 Wired network settings.....	35
5.3 WiFi networksettings.....	36
5.4 SG-15 Price Checker Settings.....	41
5.5 Configuring the Bar Code Reader.....	47
5.6 DeskTopConfigurator Which application starts at power up.....	49
5.7 Web Price Checker.....	51
5.7.1 Quick Demo Web Price Checker using On-Line Website.....	54
Chapter 6 Maintenance and Cleaning .....	57

<b>Appendices</b> .....	59
A Connector types and pin definitions.....	60
B Controlling the display and Shuttle <sup>c</sup> terminal.....	61
C Character sets.....	67
D Factory Default Settings.....	69
E Updating Applications or System Packages.....	70
G Frequently Asked Questions.....	71
H Shuttle <sup>c</sup> Project tasks.....	75
I Technical specifications.....	76
J Overview Partnumbers.....	78
K Simple Shuttle <sup>c</sup> Demo Programs.....	79
L WiFi info .....	81
N Shuttle <sup>c</sup> Control Bar Codes.....	82
P Drilling Template for Easy Mounting.....	85
Q Product Summary What's new at the SG-15 <sup>Colour</sup> .....	86



# Preface

---

The Shuttle<sup>c</sup> is an entry level, small and attractive Price Checker.

The Shuttle<sup>c</sup> features the latest technology. Interfacing is done either through Wireless RF or hard wired Ethernet. The bright colour display has, depending on the used font set, 3 or 5 lines and can display up to 20 characters per line. There is a choice of bar code scanners between the high performance 24 scan lines laser scanner, 2D imager and the low cost single scan line CCD scanner.

Because of its size and the sympathetic good looks the Shuttle<sup>c</sup> can be installed anywhere in a store, including on the shelves. This flexibility of installation is enhanced by the optional Power-over-Ethernet. The three available standard colours also greatly help to fit most interiors.

## General Information

The Scantech-ID Shuttle<sup>c</sup> is the latest product developed by the company that has over 20 years of experience in the field of customer information systems. Today we offer a choice of scanner (Laser 24 omni directional lines, 2D Imager and CCD single line), a choice of colour (Silver, Black or Red) and a choice of interface (LAN, WiFi POE).

## Quality and Durability

The Shuttle<sup>c</sup> comes with the same top quality as all other Scantech-ID products. So at a very competitive price the same quality and performance of more expensive products is available. Due to the high MTBF times of every component a long and service free operation time is secured.

## Flexibility

The size of 182mm (height), 131mm (width) and 95mm (depth), makes the Scantech-ID Shuttle<sup>c</sup> small enough to be installed in larger numbers per store. Even when mounted on a shelf it will not block products on display. The bright display makes it easy to read prices and product information.

## Connectivity

The Shuttle<sup>c</sup> is configured using a standard web browser. A customized application program -not supplied by Scantech-ID- is necessary for retailers to operate the SG-15<sup>Colour</sup> in their specific environment. Scantech supplies software source code examples plus network drivers for easy integration.



# Chapter 1 Product Safety

---

## 1.1 USED CONVENTIONS

In this manual the following conventions are used:

### **ATTENTION**

Gives a tip, an instruction or a point of attention.

### **IMPORTANT**

Warns for possible damage to the scanner or other objects when not following an instruction.

### **DANGER!**

Warns for possible harm to persons when not following an instruction.

## 1.2 LASER SAFETY

### **ATTENTION**

During installing, always follow the instructions.

### **DANGER!**

Do not stare into the laser beam. The laser safety is in conformity with IEC 825 and 21CFR140.

**German:**

Der Strichcode-Scanner SHUTTLE<sup>c</sup> entspricht den Sicherheitsvorschriften nach IEC 825-1 (1993) für ein Laserprodukt der Klasse I. Er entspricht auch U.S. 21CFR1040, anwendbar auf ein Laserprodukt der Klasse IIa. Vermeiden Sie langzeitiges Hineinblicken in direktes Laserlicht.

**Dutch:**

De SHUTTLE<sup>c</sup> scanner voldoet aan de veiligheidsnormen IEC 825-1 (1993) voor een Klasse I laserproduct. Tevens voldoet de scanner aan U.S. 21CFR1040, van toepassing op een Klasse IIa laserproduct. Vermijd langdurig kijken in direct laserlicht.

**French:**

Le scanner SHUTTLE<sup>c</sup> est conforme aux normes de sécurité IEC 825-1 (1993) s'appliquant à un produit laser de la classe I. Il est également conforme à la U.S. 21CFR1040 telle qu'elle s'applique à un produit laser de la classe IIa. Eviter de rester exposé longtemps à la lumière directe du laser.

**Danish:**

SHUTTLE<sup>c</sup> skanneren er i overensstemmelse med sikkerhedsstandarden IEC 825-1 (1993) for laserprodukter i klasse I. Den er også i overensstemmelse med U.S. 21CFR1040, der gælder for laserprodukter i klasse IIa. Undgå at se direkte på laserlys i længere perioder..

**Finnish:**

SHUTTLE<sup>c</sup>-skanneri täyttää luokan I lasertuotteelle IEC 825-1:ssä (1993) asetetut turvavaatimukset. Se täyttää myös U.S. 21CFR1040:ssa asetetut vaatimukset siltä osin kuin ne koskevat luokan IIa lasertuotetta. Vältä pitkäaikaista suoraan laservaloon katsomista.

**Swedish:**

Avsökaren SHUTTLE<sup>c</sup> uppfyller säkerhetsnormen IEC 825-1 (1993) för laserprodukter av klass 1. Den uppfyller dessutom U.S. 21CFR1040 som gäller för laserprodukter av klass IIa. Undvik att titta i direkt laserljus under längre perioder.

**Norwegian:**

SHUTTLE<sup>c</sup> skanneren er i samsvar med sikkerhetsstandarden IEC 825-1 (1993) for laserprodukter i klasse I. Den er også i samvar med U.S. 21CFR1040 for laserprodukter i klasse IIa. Unngå å se langvarig på direkte laserlys.

**Italian:**

Lo scanner SHUTTLE<sup>c</sup> è conforme alle norme di sicurezza IEC 825-1 (1993) relative ad un prodotto laser di Classe 1. È inoltre conforme alla norma U.S. 21CFR1040 relativa ad un prodotto laser di Classe IIa. Evitare l'esposizione prolungata all'emissione diretta di luce laser.

**Portuguese:**

O scanner SHUTTLE<sup>c</sup> está conforme as normas de segurança IEC 825-1 (1993) para a Classe 1 dos produtos laser. Também está conforme a norma U.S. 21CFR1040 aplicada nos produtos laser da Classe IIa. Evite expor os olhos directa e prolongadamente aos raios laser.

**Spanish:**

El scanner SHUTTLE<sup>c</sup> reúne las normas de seguridad IEC 825-1 (1993) para un producto laser de Clase 1. Y también reúne las normas U.S. 21CFR1040 que se aplican a un producto laser de Clase IIa. Se debe evitar mirar muy fijo en luz láserica directa.

**English:**

The SHUTTLE<sup>c</sup> scanner complies with safety standard IEC 825-1 (1993) for a Class I laser product. It also complies with U.S. 21CFR1040 as applicable to a Class IIa laser product. Avoid long term viewing of direct laser light.

**Optical:**

The use of optical instruments with this product will increase eye hazard. Optical instruments include binoculars, microscopes and magnifying glasses but do not include eyeglasses worn by the user.

**Radiant Energy:**

The SHUTTLE<sup>c</sup> uses a low-power laser diode operating at 630...670 nm in an opto-mechanical scanner resulting in less than 0.6 mW peak output power. Laser light observed at 13 cm (5.1 in.) above the window through a 7 mm (0.28 in.) aperture and averaged over 1000 seconds is less than 3.9  $\mu$ W per CDRH Class IIa specification. Do not attempt to remove the protective housing of the scanner, as unscanned laser light with a peak output up to 0.8 mW could be accessible inside.

**Laser Light Viewer:**

The scanner window is the only aperture through which laser light may be observed on this product. A failure of the scanner motor, while the laser diode continues to emit a laser beam, may cause emission levels to exceed those for safe operation. The scanner has safeguards to prevent this occurrence. If, however, a stationary laser beam is emitted, the failing scanner should be disconnected from its power source immediately.

**Adjustments:**

Do not attempt any adjustments to or alteration of this product. Do not remove the scanner's protective housing. There are no user-serviceable parts inside.

**CAUTION**

Use of controls or adjustments or performance of procedures other than those specified herein may result in hazardous laser light exposure.

# 1.3 DECLARATION OF CONFORMITY

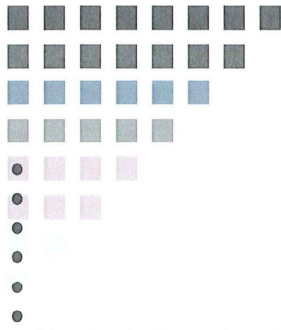

## DECLARATION OF CONFORMITY

**Scantech-ID B.V.**

**SCANTECH ID**  
CHAMPTEK Group

Heliumweg 34 A  
3812 RE Amersfoort  
The Netherlands  
tel. +31 (0)33 4698 400  
fax +31 (0)33 4650 615



**Hereby declares that the product:**

Product: **Shuttle<sup>C</sup> SG-15<sup>Colour</sup> Price Checker**  
Model/Part number(s): **718A7 n0n04n n000** (Ref: User's Manual Appendix J)

**Product View:**



**Will comply with the following product specifications:**

- Laser safety IEC 825-1 (1993) Class I, U.S. 21CFR1040 Class IIa
- Electrical safety LVD-EN60950-1
- EMC
 

EN5022 CLASS A:2010/AC:2011  EN61000-3-2: 2014 EN61000-3-3: 2013 EN55024:2010  IEC 61000-4-2:2008 IEC 61000 3: 2006+A1:2007+A2:2010 IEC 61000-4-4:2012 IEC 61000-4-5:2014 IEC 61000-4-6:2013 IEC 61000-4-8:2010 IEC 61000-4-11:2004	CE RED EN300328(1.9.1) RED EN301489-1/EN301489-17 EN301893 RF-WLAN UNII BAND 1 (ac) EN301893 a WLAN  FCC FCC Part 15C FCC Part 15B RF-WLAN 802.11a (W52/W53) RF-WLAN 802.11ac (W56 )
---	--

**Means of conformity:**

We confirm to comply with the requirements set out in the Council Directive of the Laws of the Member States relating to Electromagnetic Compatibility (2004/108/EC) and (2006/95/EC) for the evaluation regarding the electromagnetic compatibility.

The above product is in compliance with the (RoHS II) Directive 2011/65/EU by July 1, 2011.

Signature

Allen Wang,  
Quality Manager  
October 2016



# 1.4 PRODUCT LABELLING

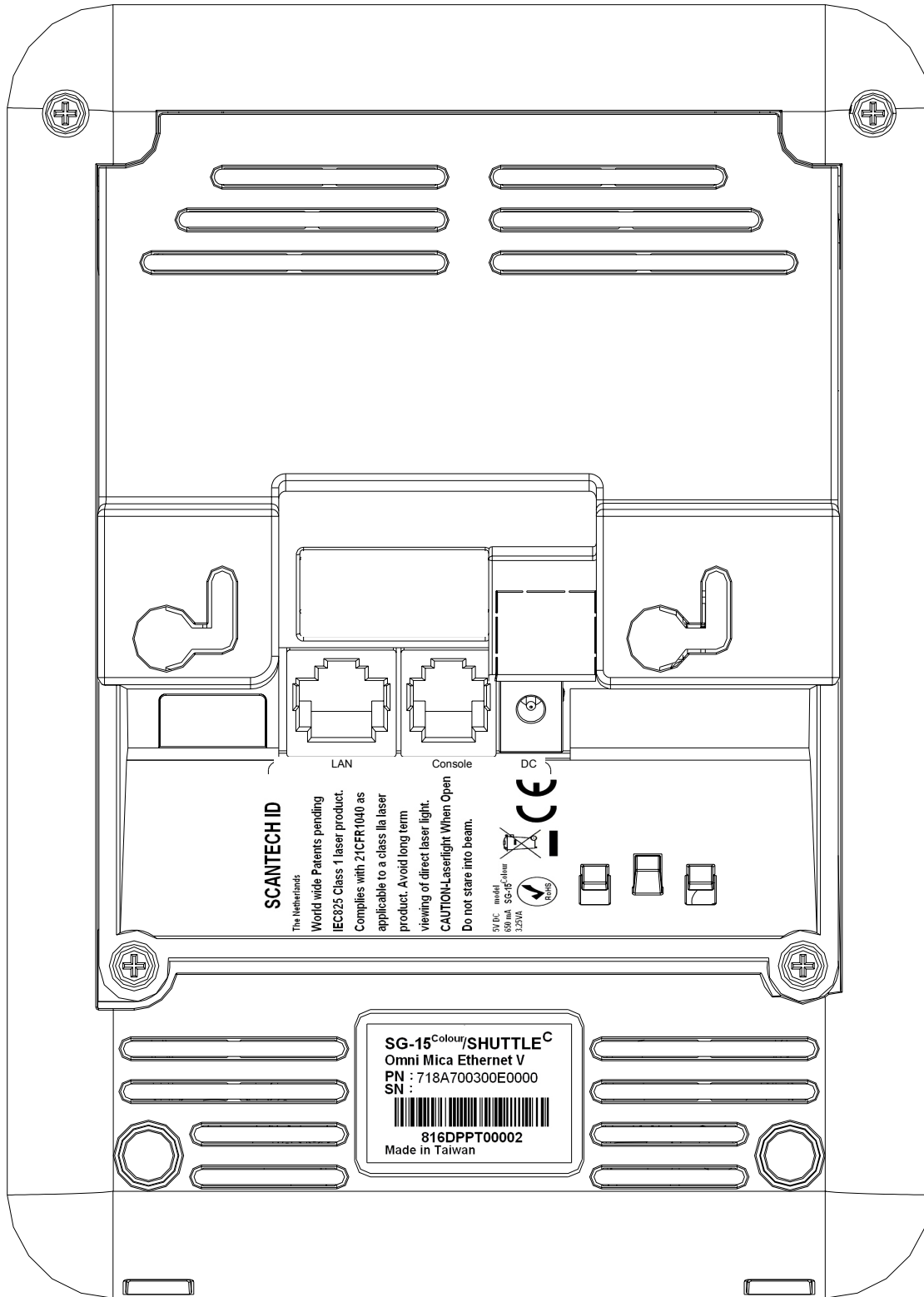



## **Chapter 2 General Description**

---

## **2.1 USE OF THE SHUTTLE<sup>c</sup>**

The Shuttle<sup>c</sup> is a Price Checker, which provides the user with the opportunity to scan their chosen product and display product information or verify the price before getting to the checkout. Apart from this, the Shuttle<sup>c</sup> offers the ability to interface with loyalty cards, display special offers, display dual currency, etc. Moreover, store level profitability can be increased.

Apart from the use as an advanced price checker, the Shuttle<sup>c</sup> can also be used in many other environments where identification and information is required. This includes use with ticketing, access control, time check, route and place guidance and item check in a warehouse or stockroom.

## 2.2 CONSTRUCTION OF THE SHUTTLE<sup>C</sup> SG-15<sup>COLOUR</sup>

The various parts of the Shuttle<sup>C</sup> are indicated in figure 2.1:

- A. Front housing with window
- B. Colour TFT-LCD  
Display size is 320X240 pixels QVGA 70 X 53 mm  
Color Depth 16.7M Colours
- C. Back Housing
- D. Scantech-ID omni-directional scanner, 2D Imager or CCD single line scanner
- E. Main board
- F. Back Cover.

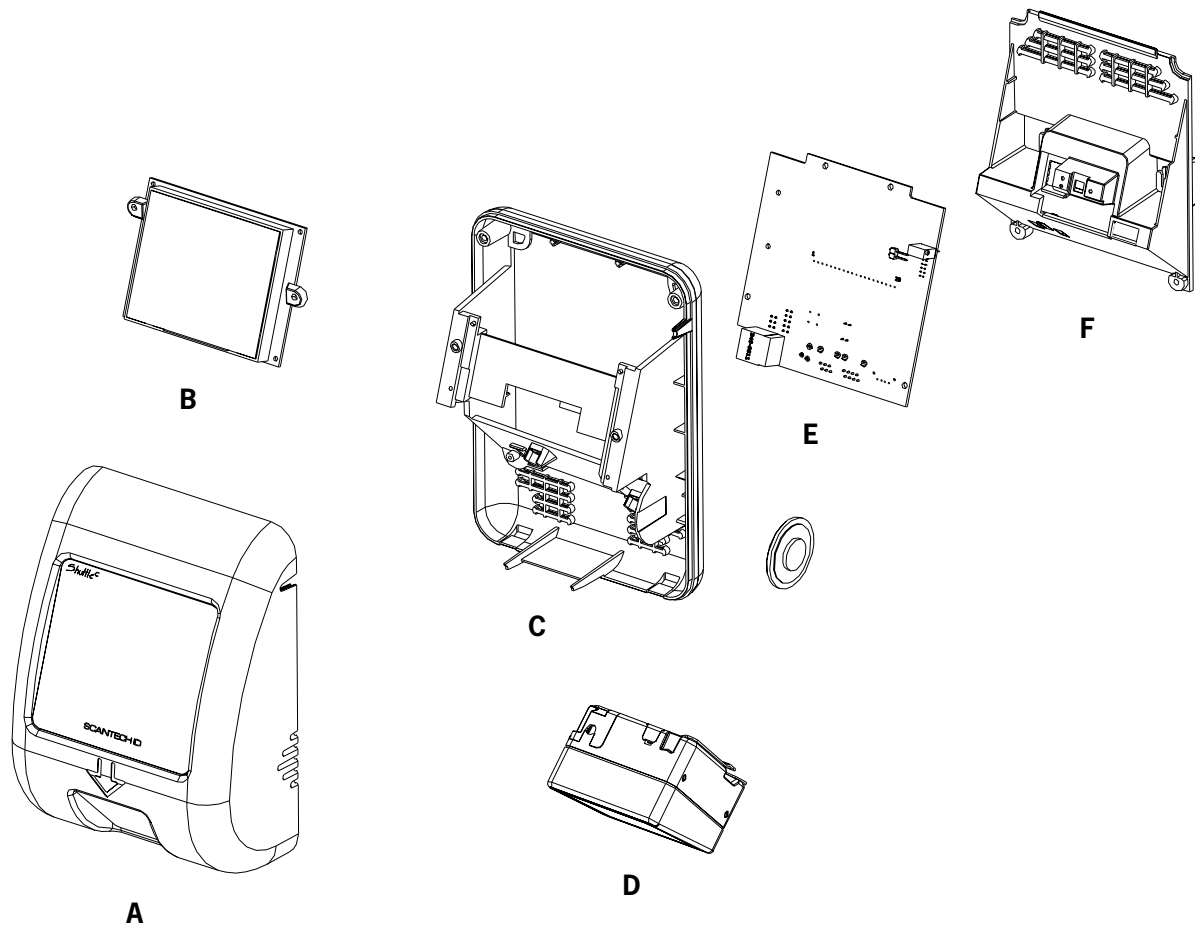

Fig 2.1

## **2.3 FUNCTIONING OF THE SHUTTLE<sup>C</sup> SG-15<sup>COLOUR</sup>**

### **2.3.1 Introduction**

The Shuttle<sup>C</sup> is an information terminal, which receives input (barcode), from a user and answers via the display. The display contents is provided by a computer application, which runs on a (server) system elsewhere.

### **2.3.2 Input**

The main input -bar code information- is generated by the integrated Scantech-ID barcode reader, which is characterised by a high performance 24 scan line omni-directional laser scan pattern. Or from the optional available 2D imager or CCD single line scanner.

### **2.3.3 Output**

Based on the bar code input and the application software on the host-system the Shuttle<sup>C</sup> communicates with the user via text on the screen and optional graphics and audio feedback via the speaker.

### 2.3.4 Software & Control

The functions during daily use of the Shuttle<sup>c</sup> are determined by the application program, which is controlling the Shuttle<sup>c</sup>. So the task of the storage of databases, providing the information and sending it to the display of the Shuttle<sup>c</sup> will be performed by a central host system.

Providing this application, running on the host system, is the responsibility of the System Integrator.

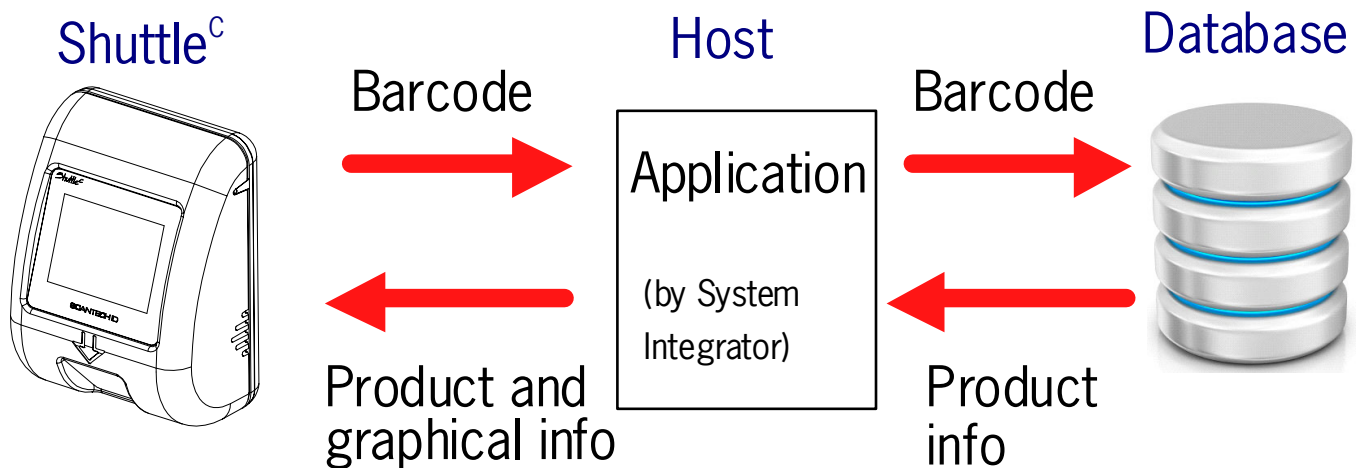

The SG-15<sup>Colour</sup> sends barcodes to the host, according to the following table:

CODE	MESSAGE FORMAT
EAN-13	F D1 D2 D3 D4 D5 D6 D7 D8 D9 D10 D11 D12 D13 [CR]
EAN-8	FF D1 D2 D3 D4 D5 D6 D7 D8 [CR]
UPC-A	A D1 D2 D3 D4 D5 D6 D7 D8 D9 D10 D11 D12 [CR]
UPC-E	E Ø D1 D2 D3 D4 D5 D6 [CR]
ITF	i D1 - Dx [CR]
Code 39	* D1 - Dx [CR]
Code 32	* D1 - Dx [CR]
Codabar	% D1 - Dx [CR]
Code128	# D1 - Dx [CR]
EAN-128	P ]C1 D1 - Dx [CR]
DataBar	R D1 - Dx [CR]

The Shuttle<sup>c</sup> documentation and the demo/set-up programs provide you with all the required information on how to communicate with the Shuttle<sup>c</sup> and how to control it. The SG-15<sup>Colour</sup> Product Support Library contains all kind of source code examples and a complete example for application software (incl. free source code), including an Ethernet driver to enable the integrator to get the SG-15<sup>Colour</sup> up and running in no time.

## 2.4 POWER OVER ETHERNET (POE)

The alternative for powering the Shuttle<sup>C</sup> through an external PSU (adapter), is using the Power-Over-Ethernet (PoE) version of the SG-15<sup>Colour</sup>.

In this way the SG-15<sup>Colour</sup> is powered directly through the Ethernet and you don't need to install a (230/110VAC) mains socket anymore somewhere in the middle of the store, so in this way saving you quite some installation costs!

The Shuttle<sup>C</sup> PoE complies with the official standard: IEEE 802.3af.

For your information:

PoE uses either the 4 Ethernet data lines (pin 1,2,3,6), called End-Span, or the not used Ethernet lines (pin 4,5,7,8), called Mid-Span, to transport the DC voltage to the SG-15<sup>Colour</sup>. Which method is used, depends on the supplying powered network switch (hub). The Shuttle<sup>C</sup> supports both methods automatically.

See also Appendix A.

Towards the host-side, this means that you need a special hub/router which supports the Power-Over-Ethernet (PoE) feature following the official standard for this: IEEE 802.3af.

To avoid any miscommunication in this area: **Scantech does not supply network components like a power injector, network cabling, powered hubs etc.**

When we ship the first unit(s) SG-15<sup>Colour</sup> PoE in the current stage, this is in most cases for demo- or evaluation purposes. Therefore we DO include the standard PSU. This is done 'just to be sure' and to give our customers the possibility to at least turn-on the SG-15<sup>Colour</sup> independent from the hub, for instance for SG-15<sup>Colour</sup> configuration purposes.

Of course, for the real installation in the store (roll-out), with the SG-15<sup>Colour</sup> connected to a hub with Power-Over-Ethernet IEEE 802.3af, you do not need the mains PSU (adapter).

In case a project roll-out starts, we will not include the mains PSU anymore.

Physically (i.e. inside the SG-15<sup>Colour</sup>) this means that we place a special PoE board to support the PoE feature. See Appendix J for SG-15<sup>Colour</sup> POE Partnumbers.

## **Chapter 3 Installation of the Shuttle<sup>C</sup> SG-15<sup>Colour</sup>**

---

## 3.1 UNPACKING

Unpack the Shuttle<sup>c</sup> as follows:

1. Take the Shuttle<sup>c</sup> and its accessories out of the box.
2. Remove the packing material.
3. Check the packing list to make sure you have received all of the items ordered.
4. Visually inspect the Shuttle<sup>c</sup> and accessories for any evidence of physical damage.
5. If anything is missing or appears to be damaged, immediately contact your dealer.

### **ATTENTION**

Store the packing material and boxes: it should be used whenever the Shuttle<sup>c</sup> is transported for servicing.

## 3.2 MOUNTING

Once you have unpacked all components, you can start installing the Shuttle<sup>c</sup>.

Installing the Shuttle<sup>c</sup> is divided in two steps:

1. Mounting the Shuttle<sup>c</sup> to the wall.
2. Installation is discussed in detail on the following page.



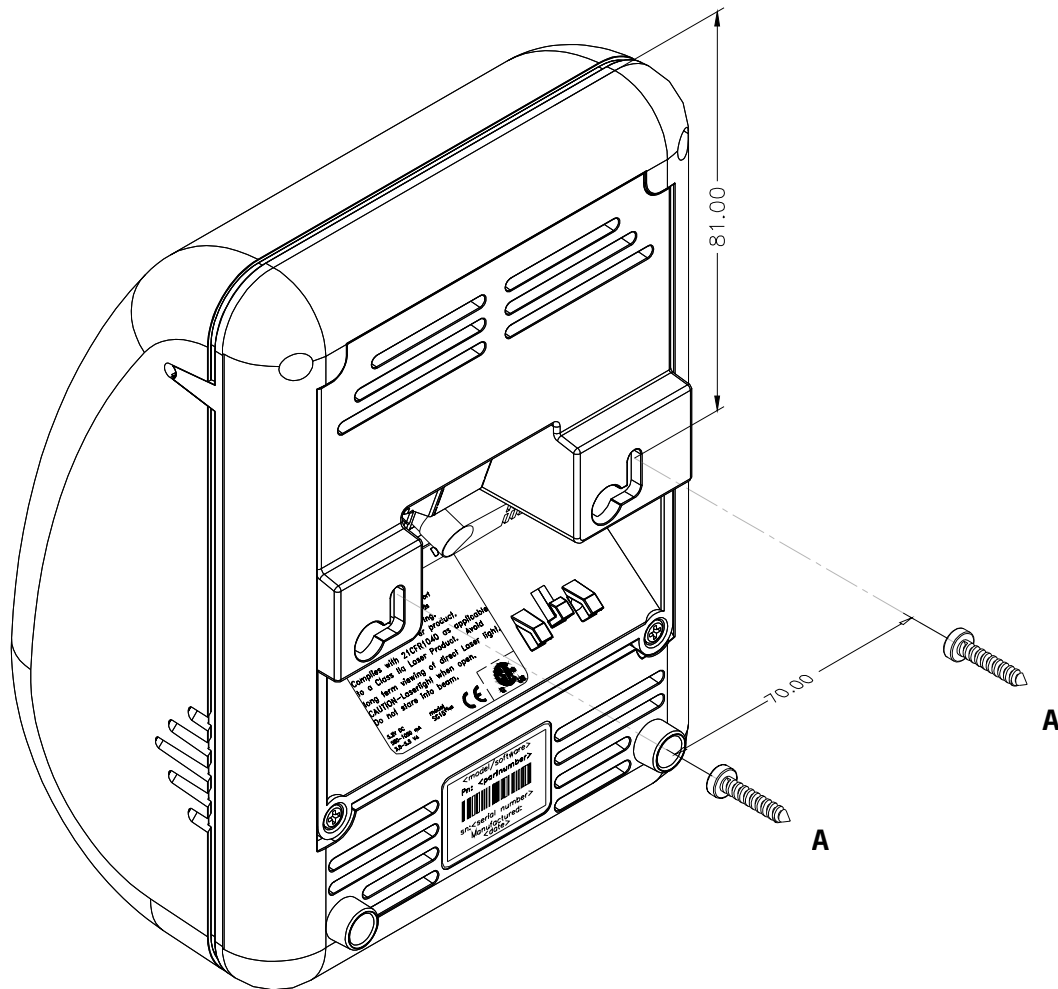

fig 3.1

**ATTENTION**

Mount the Shuttle<sup>c</sup> on a height for convenient

- view of the display
- scanning of the articles.

1. See Drilling Template in Appendix P and mark the locations for the mounting holes on the wall and drill the two holes.
2. Put plugs in the holes.
3. Connect the power cable and the communication cable of the Shuttle<sup>c</sup> (see figure 3.1 above).
4. Fasten the Shuttle<sup>c</sup> to the wall by clicking it on the 2 screws (parkers, indicated by A).

# **Chapter 4 System Integration**

---

## 4.1 SOFTWARE

The Shuttle<sup>c</sup> is a thin-client, front-end Price Checker. Its behavior is very easily configurable and fully determined by the software package, driving the Shuttle<sup>c</sup> from the Back-Office/server. This software package (or: added value) will be supplied by the System Integrator. This is because of the fact that there are no set international standards with regard to product database structures and/or programming languages. Furthermore it is not Scantech's primary role to supply end-user application software.

### ATTENTION

The SG-15<sup>Colour</sup> Product Support Library contains a framework of software tools which includes an Ethernet driver and a complete demo application (including free of charge source code).

This makes it very easy to create a server application in no time at all.

These objects are available for both Windows and Linux

See Product Support Library \Source Code Examples\Enhanced

### 4.1.1 Software functionality

The global function of the Shuttle<sup>c</sup> software package, running on the Back-Office/server, is:

1. Set-up and maintain communication between the application itself and the Shuttle<sup>c</sup> terminal(s).
2. Provide product information (e.g. article name and price) from the store's database, combined with the right font size and layout.
3. Diagnostics & Terminal Statistics (optional).

## 4.1.2 Scantech Tools and Drivers

In order to support our System Integrators in the best possible way, Scantech ID supplies:

1. Extensive documentation describing all details of the product. (this manual and more).
2. Built-in Configuration Utility through web browser: See Chapter 5.

### **ATTENTION**

The SG-15<sup>Colour</sup> runs an embedded web server for configuration purposes. This makes it possible to configure an SG-15<sup>Colour</sup> with any modern internet browser.

3. Examples of source code:  
See Product Support Library \Source Code Examples.

All these items can be found in the Shuttle<sup>C</sup> Product Support Library.

### 4.1.3 Compatibility and Integration

The SG-15<sup>Colour</sup> is an entry level Price Checker with basic function and has a compact set of commands to control it.

1. The SGPriceChecker application, running on the SG-15<sup>Colour</sup> (Ref: Chapter 5.4), makes it backward compatible with the previous models: SG-15 and SG-15<sup>Plus</sup>, regarding data communication.

So, no changes needed in the existing back-office software.

The unit configuration is done using any modern internet browser.

2. As of the SG-15<sup>Colour</sup>, the Shuttle can be configured in such a way, it is backward compatible with the Discovery SG-20<sup>\*1</sup>. See Chapter 5.4 for configuration details.

This SG-20 emulation function implies: supporting general price-checking function:

- Scan the bar code and send the scanned data to the host like an SG-20
- Receive data from the host/store-server, as it was intended for the SG-20 display.
- Show product name and price on the SG-15<sup>Colour</sup> display.

In case you created an SG-20 application on the back-office in the past, controlling the SG-20, you can continue using this application without any changes on the backoffice.

The terminal configuration takes place using the regular SG-15<sup>Colour</sup> web server.

To avoid any misunderstanding: The SG-15<sup>Colour</sup> cannot be configured using the SG-20 Configuration Tool.

3. As of October 2016 the SG-15<sup>Colour</sup> contains a second application for easy and uptodate integration in the Retailer's IT structure: The Web Price Checker. See Chapter 5.7 for details.

With the Desktop Configurator you select which application is active after powering up the SG-15<sup>Colour</sup>. Ref: Chapter 5.6 for details.

\*1: SG-20 Ethernet model



## **Chapter 5 Configuring the Shuttle<sup>®</sup>**

---

## 5.1 Making First Connection and Login

The information given below is based on SG-15<sup>Colour</sup> firmware V0.9.3.

The SG-15<sup>Colour</sup> has an internal web server for configuration purposes. Just start your web browser Chrome, Firefox or Internet Explorer and enter the IP-address of the SG-15<sup>Colour</sup>. Note: Use for Internet Explorer version 11 or higher.

The SG-15<sup>Colour</sup> comes with installed Factory Default Settings and at startup it will try to connect to a LAN network with enabled DHCP service.

When there is no DHCP service active, the SG-15<sup>Colour</sup> will use 192.168.1.200 as default IP-address for the LAN interface.

The unit's IP address is shortly visible on the launcher screen after power-up, both Ethernet and WiFi.

Make sure your computer is in the same IP subnet as the SG-15<sup>Colour</sup> you're going to configure.

E.g.: The SG-15<sup>Colour</sup> has IP address 192.168.1.200 and your computer has address 192.168.1.250.

The physical connection with the SG-15<sup>Colour</sup> is made using an Ethernet cross-cable or alternatively through your local network:

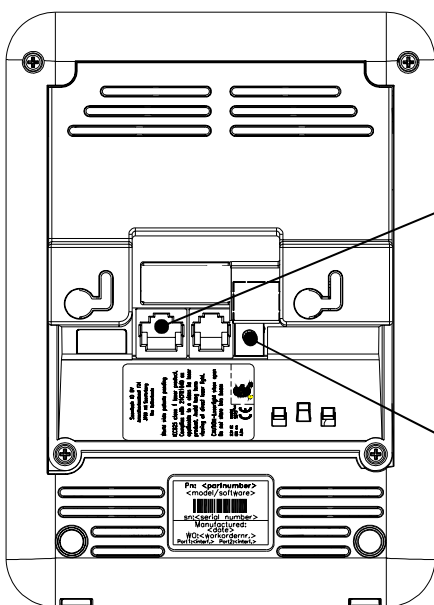

LAN port connecting the unit to the network

DC jack connects the 5VDC power adapter.



## Login Page

To manage SG-15<sup>Colour</sup> settings, it runs a web server in https mode for exchanging queries and responses with a modern browser (Chrome, Firefox or IE).

Enter the SG-15<sup>Colour</sup> IP address in the address bar of your browser to open the login page. Prior to accessing the login page, you will receive an SSL warning from your browser which you can ignore by clicking « Proceed anyway »

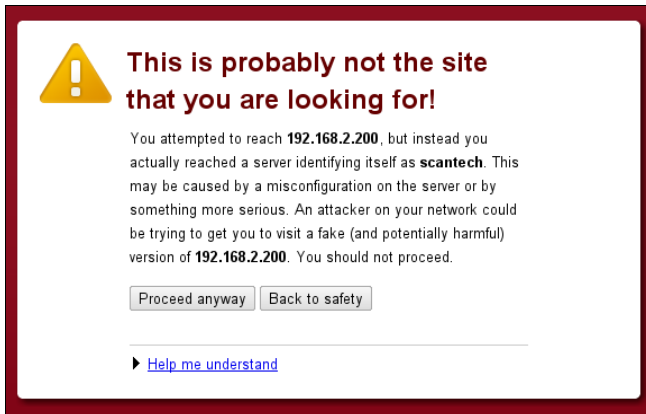

The login page appears and you can login with:

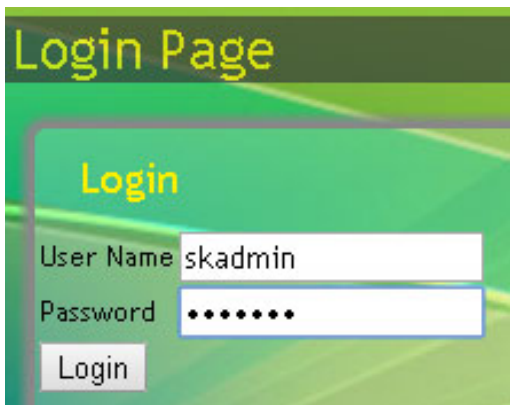

user name           **skadmin**

default password   **skadmin**

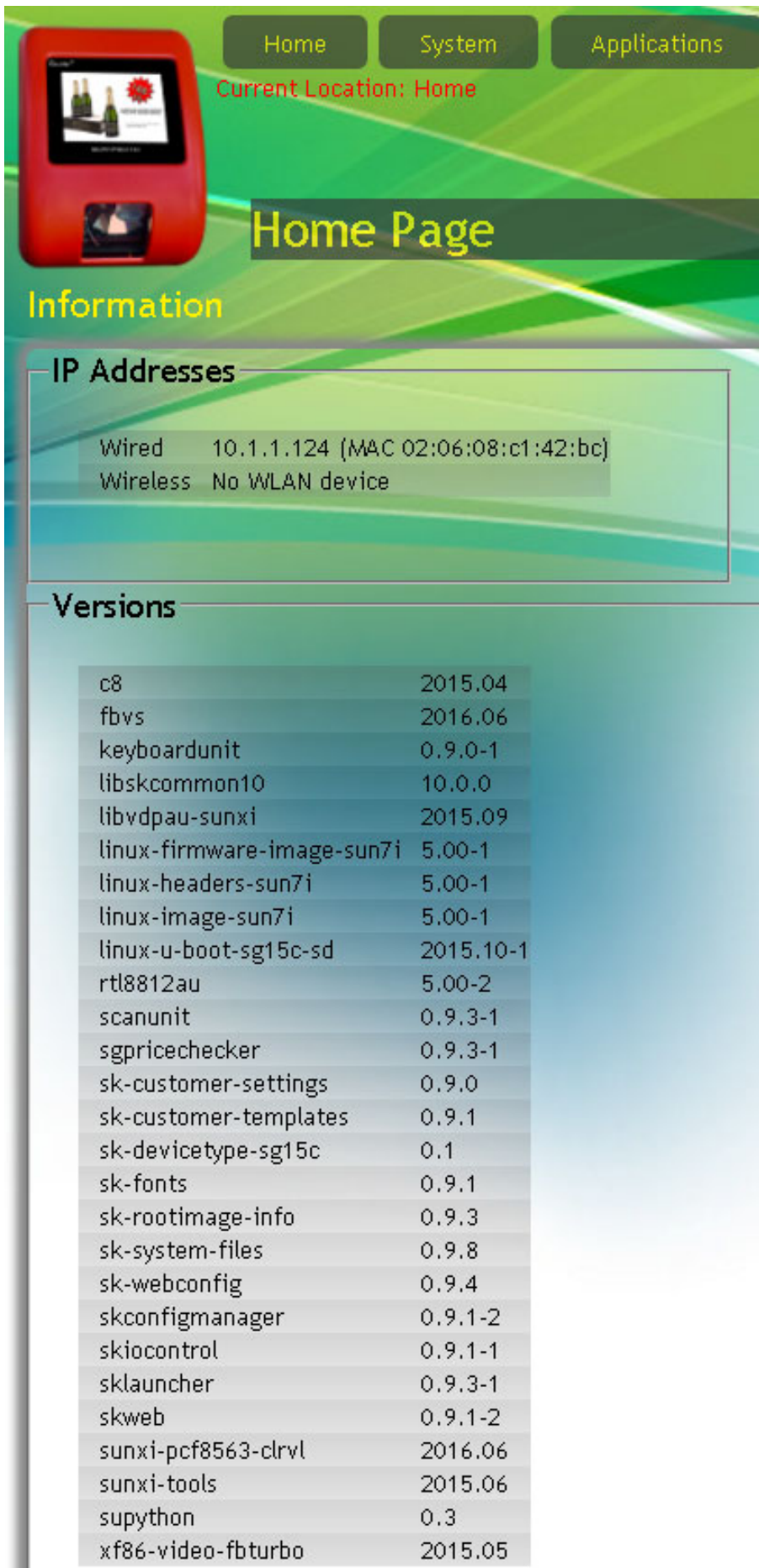

Home System Applications

Current Location: Home

## Home Page

### Information

#### IP Addresses

Wired 10.1.1.124 (MAC 02:06:08:c1:42:bc)  
Wireless No WLAN device

#### Versions

c8	2015.04
fbvs	2016.06
keyboardunit	0.9.0-1
libskcommon10	10.0.0
libvdpau-sunxi	2015.09
linux-firmware-image-sun7i	5.00-1
linux-headers-sun7i	5.00-1
linux-image-sun7i	5.00-1
linux-u-boot-sg15c-sd	2015.10-1
rtl8812au	5.00-2
scanunit	0.9.3-1
sgpricechecker	0.9.3-1
sk-customer-settings	0.9.0
sk-customer-templates	0.9.1
sk-devicetype-sg15c	0.1
sk-fonts	0.9.1
sk-rootimage-info	0.9.3
sk-system-files	0.9.8
sk-webconfig	0.9.4
skconfigmanager	0.9.1-2
skiocontrol	0.9.1-1
sklauncher	0.9.3-1
skweb	0.9.1-2
sunxi-pcf8563-clrvt	2016.06
sunxi-tools	2015.06
supython	0.3
xf86-video-fbturbo	2015.05

On the Home Page you see an overview of the package Versions.

## 5.2 Configure the SG-15<sup>Colour</sup> Wired network settings

On the Configuration Web Page Wired Network configuration you set the IP address of the SG-15<sup>Colour</sup> terminal:

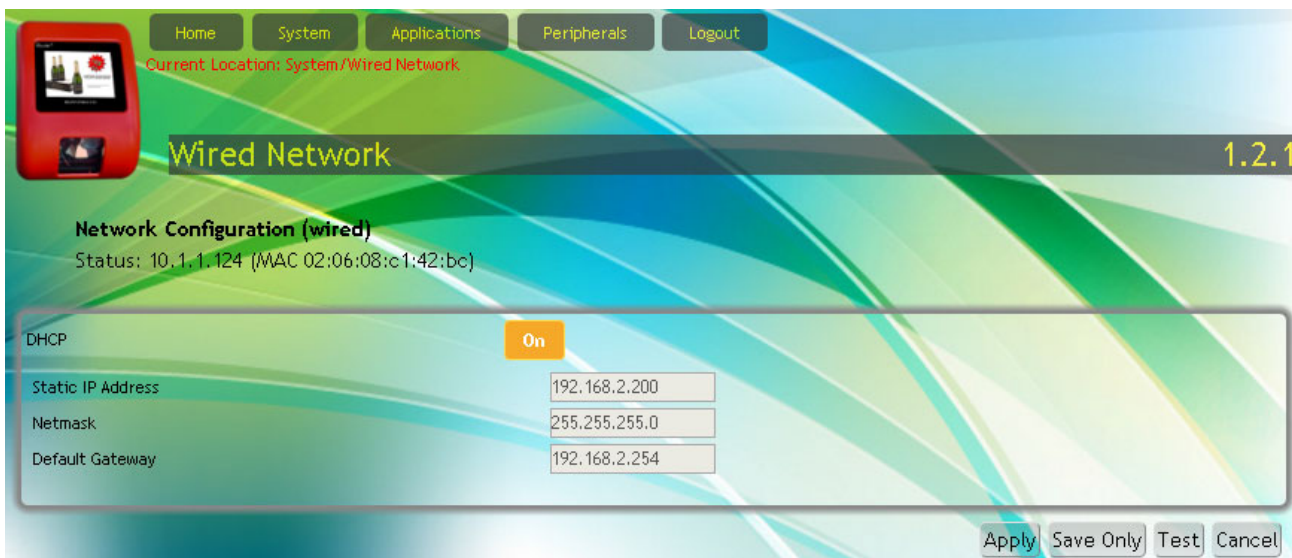

With Factory default settings, the SG-15 starts with DHCP=On and settings as displayed above.

At startup, the assignment of an SG-15 IP-address takes place according the following procedure:

1. When DHCP is enabled and a DHCP-service is active on the network, the SG-15 will use the IP-address assigned by the DHCP-service.
2. When DHCP is enabled but the DHCP-service is not active on the network, by default the SG-15 will use Static IP Address: 192.168.1.200.
3. When DHCP is disabled, the remaining fields in the section become editable and the SG-15 will « [Apply](#) » the entered values as such.

Important: When changing the LAN settings with « [Apply](#) », your SG-15 will immediately disconnect from your browser. For re-connecting your browser you must match the network settings of your PC compatible with those of your SG-15. After re-connecting and re-opening web-page [System->Wired Network](#), the Status line will display the new IP-address. The Save Only button prevents the connection loss and the newly inputted IP address will become valid after repowering the unit.

When the SG-15 shortly displays the DeskTop menu after power-up, you can read the IP-addresses assigned to LAN (and WLAN) directly from the display.

Wired Network settings, cont'd information:

- Static IP Address: fixed IP-address (only editable when DHCP=Off).
- Netmask: determines the class of network.
- Default Gateway: default IP-address used by the SG-15 whenever it addresses IP's that do not match any other routes in the SG-15's routing table.

Notes:

1. The Default Gateway address always shares the network value for the Static IP Address.
2. In combination with WLAN it is sometimes necessary to define no Default Gateway for LAN which is done by leaving this field empty.

## 5.3 Configure the SG-15<sup>Colour</sup> WiFi network settings

On this Configuration Web Page you input the WiFi Network settings:

### Introduction

Changing WLAN settings is best done by connecting the SG-15 with a Ethernet cross-cable to your PC/Laptop. With DHCP=OFF, the SG-15 will activate 192.168.1.200 as default IP-address for LAN.

Make sure your PC/Laptop has a compatible network setting and login.

Note that the SG-15 runs the LAN and WLAN interfaces simultaneously. In real live applications, only one of the two interfaces will be used to communicate with the server application.

Notes:

1. At start-up and Wifi-Enable=On, the assignment of the WLAN IP-address is done as follows:
  1. When DHCP is enabled and a DHCP-service is available on the network, the SG-15 will use the IP-address assigned by the DHCP-service (the Access Point becomes transparent for any LAN network with an active DHCP-service that answers first in time).
  2. When DHCP is enabled but no DHCP-service is available on the network, the SG-15 will use 192.168.4.201 as default IP-address.
  3. When DHCP is disabled the SG-15 will use the static IP-address value (192.168.4.200 factory default).
2. SG-15<sup>Colour</sup> Wi-Fi devices provided by Scantech-ID support the hidden SSID feature (controlled by the Access Point).
3. If a Default Gateway is required for the Wi-Fi network then make sure that the Default Gateway for LAN is omitted (the reserved field for this must be empty).
4. At start-up and Wifi-Enable=On, the wifi-driver will immediately attempt to set-up a connection with the given SSID. If the Access Point is not available, the SG-15 will continue searching for the SSID until it finds it.
5. WLAN authentication data is never stored on the device itself.
6. The password for the SSID can be made visible with the tick-box Show Password.
7. The button « [Save Only](#) » allows you to change the Wifi settings without actually activating the Wifi connection. This is useful when configuring Wifi without an Access Point i.e. it avoids unnecessary waiting for connection timers to time-out.
8. The WPA/WPA2-Enterprise implementation supports 802.1x authentication by means of a RADIUS server. The fields Username and Password must match with those registered on the RADIUS server.

The screenshot shows a configuration window for WPA-Enterprise authentication. The 'Network Name (SSID)' field contains 'scantech'. Under 'Encryption Type', 'wpa-ent' is selected. The 'Username' field contains 'UserName' and the 'Password' field contains 'myPassword'. A 'Show Password' checkbox is checked. The 'Validate server certificate' option is set to 'Off'.

Note: The feature Validate Server Certificate is not yet implemented.

9. SG-15<sup>Colour</sup> with WLAN support IEEE 802.11 a/b/g/n/ac, dual-band 2.4GHz/5GHz.

## Legend Status

After entering your Wifi settings and « [Apply](#) », the *Status* line in top of the page will show the new SG-15-WLAN network interface settings. A successful WLAN connection will be shown in the webpage

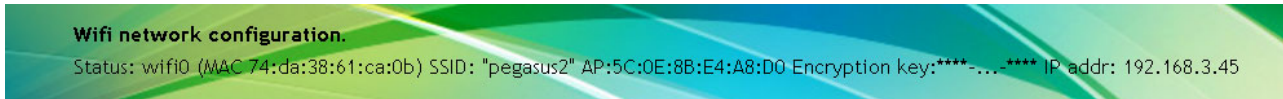

Entering an « [Apply](#) » to setup a WLAN connection with correct settings and good signal quality takes less than 10 seconds and the message Apply executed OK will confirm a successful operation.

Note: Always check first if a WLAN device is installed and that Wifi-Enable=On.

Ref: Appendix J with the product partnumbers for SG-15<sup>Colour</sup> WiFi versions.





Home
System
Applications
Peripherals
Logout

Current Location: Applications / SGPriceChecker

## SGPriceChecker

**SG Type**  SG15  SG20

**SGNET**

Server Address

Server Port

Connect Mode  TCPclient  TCPserver  UDP

---

**Code Categories**

1D Barcodes  On

2D Barcodes  Off

RFID Tags  Off

Unknown Category  Off

---

**General**

Foreground Colour

Background Colour

---

**SG15**

Idle Display Mode  Text  Image

Invert Display  Off

Text Direction  Left->Right  Right->Left

Codepage

TAit/THold - Display Message Time

TWait - Server Response Time

Idle Message Line 1:	<input type="text" value="Welcome"/>	Font:	<input type="text" value="large"/>	Align:	<input type="text" value="X-center Y-top"/>	X:	<input type="text" value="0"/>	Y:	<input type="text" value="0"/>
Idle Message Line 2:	<input type="text" value="Scan your product"/>	Font:	<input type="text" value="small"/>	Align:	<input type="text" value="X-center"/>	X:	<input type="text" value="0"/>	Y:	<input type="text" value="30"/>
Idle Message Line 3:	<input type="text" value="here..."/>	Font:	<input type="text" value="small"/>	Align:	<input type="text" value="X-center"/>	X:	<input type="text" value="0"/>	Y:	<input type="text" value="45"/>
Error Message Line 1:	<input type="text" value="Please contact a"/>	Font:	<input type="text" value="small"/>	Align:	<input type="text" value="X-center"/>	X:	<input type="text" value="0"/>	Y:	<input type="text" value="15"/>
Error Message Line 2:	<input type="text" value="member of staff"/>	Font:	<input type="text" value="small"/>	Align:	<input type="text" value="X-center"/>	X:	<input type="text" value="0"/>	Y:	<input type="text" value="30"/>
Offline Message:	<input type="text" value="- Offline -"/>	Font:	<input type="text" value="small"/>	Align:	<input type="text" value="X-center Y-center"/>	X:	<input type="text" value="0"/>	Y:	<input type="text" value="0"/>



## 5.4 SG-15 Price Checker Settings

Navigate via Applications to the SGPriceChecker Configuration Web Page, where you configure the Price Checker settings:

### 5.4.1 SGNET

SGNET

Server Address

Server Port

Connect Mode  TCPclient  TCPserver  UDP

Fill in the fields Server Address and Server Port for connection to the host/server with the application controlling the SG-15<sup>Colour</sup>, for instance SGNET service. The Connect Mode can be TCP Client, Server or UDP (no-connection/state-less).

### 5.4.2 Idle Display Mode

Idle Display Mode  Text  Image

These buttons allow you to select between displaying a [Text](#) message or an [Image](#) when the SG-15 enters idle mode. The idle text message is defined by the reserved Idle Message Lines[1-3], see below. When [Image](#) is selected, the SG-15 will continuously display file image1.gif. Animated gif or files of type png, jpg or bmp are also supported. Uploading is done under Templates/main/sg15.

### 5.4.3 Invert Display

Invert display

When using the SG-15<sup>Colour</sup> in backward compatibility mode, it displays white characters on a blue background.

This static behavior inverts for Invert Display « [ON](#) ».

### 5.4.4 Screen colour selection

Foreground Colour

Background Colour

Alternatively you can input the RGB or HTML colour codes. Ref: <http://htmlcolorcodes.com/>

### 5.4.5 Code-pages



The SG-15 supports 12 character sets which you can select from the Codepage drop-down menu. Each character set (code-page) is available in 2 font sizes.

#### Notes:

- Font size selection is encoded in the server reply message as an <ESC>command, see table below.
- Code-page selection is done by web page configuration (i.e. static).
- Code-pages are installed as files in directory `/apps/config/sg15` and are managed with the «[Download](#)» and «[Upload](#)» buttons in web page «[System>Templates](#)».

### 5.4.6 Timing

SG-15 provides two time-out parameters in seconds as follows:

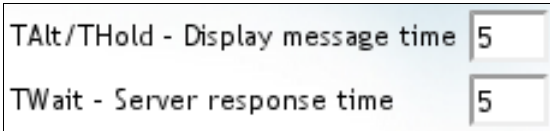
Timer	Legend
$T_{Alt}/T_{Hold}$	 <p>Display duration for each Idle message when the SG-15 is in Idle mode. Display duration of reply message from server after scanning a barcode. For <math>T_{Hold} = 0</math> the replied message stays on screen until replaced by another.</p>
$T_{Wait}$	Time the SG-15 will wait for server to reply on barcode request before displaying an error message.

## 5.4.7 Messages

This section allows you to define 3 types of messages: Idle, Error and Offline. Each message has a number of reserved lines for entering text. The attributes font, align and XY offsets gives a certain freedom to visualize the messages.

Table with legend for message details:

Idle #Message Line 1:	Welcome	Font: large ▼	Align: X-center Y-top ▼	X: 0	Y: 0
Idle #Message Line 2:	Scan your product	Font: small ▼	Align: X-center ▼	X: 0	Y: 30
Idle #Message Line 3:	here...	Font: small ▼	Align: X-center ▼	X: 0	Y: 45
Error #Message Line 1:	Please contact a	Font: small ▼	Align: X-center ▼	X: 0	Y: 15
Error #Message Line 2:	member of staff	Font: small ▼	Align: X-center ▼	X: 0	Y: 30
Offline #Message:	- Offline -	Font: small ▼	Align: X-center Y-center ▼	X: 0	Y: 0

Message	SG-15 Mode	Legend
Line[1-3]	Idle	These messages are displayed when for Idle Display Mode button Text is selected (each message remains $T_{Alt}$ sec on screen). All messages are editable with a browser. Messages longer than the display line length are wrapped around to the next line, empty message fields are skipped.
Line[1-2]	Error	Is displayed when the server does not reply within $T_{Wait}$ second after sending the barcode request.
Line[1]	Offline	Shown when the SGPriceChecker service on the server is not available <sup>1</sup> at start-up. The SG-15 emulation stays in this mode until the server connection returns.

### Notes:

- The number of characters you can display per line depends on the font size and the code-page. Wrap-around of text is NOT supported so extra characters beyond this number are not or partly displayed.
- Defining a new message string page is done with a browser, which will use the locally defined code page of your PC or Laptop. When clicking «Accept» the SG-15 emulation will re-map the entered string according to the selected SG-15 code page.

## 5.4.8 SG-15 Display Features



## Features

- 64 x 128 pixels
  - Mono-chrome
  - No text wrap-around
  - Standby mode for Background Display Light
- } When using SGPriceChecker application,  
providing SG-15 backward compatibility mode.

### 5.4.9 SG-15 <ESC><COMMAND> compatibility table

The following table represents the list of <ESC> commands:

<ESC><COMMAND>	Command Character	Legend
C_CLEARISPL	0x25	Clear screen (clear screen and cursor moves to home position i.e. Top-Left)
C_CURSORPOS	0x27	Position cursor (X[0-15], Y[0-4])
C_ALIGN	0x2E	Align a string of text: Left-Top, Center-Top, Right-Top etc.
C_STANDBY <sup>1</sup>	0x40	De-activate TFT-backlight and scan-engine
C_WAKEUP <sup>2</sup>	0x41	Activate TFT-backlight and scan-engine
C_SETFONT	0x42	Select between font size-1 or -2
C_PIXELPOS	0x44	Set Pixel Position (X[0-127], Y[0-63])
C_SHOWGIF	0x58	Show image[1-4] (can be gif, jpg, png bmp).
C_RESET	0x5A	SGPriceChecker restarts by parent process (launcher)
C_SCANNING	0x5B	Disable and Enable scanning by scan-engine: Not Implemented
C_BACKLIGHT	0x5C	Enable/Disable TFT-backlight
C_BEEP	0x5E	Internal speaker will beep: Not Implemented
C_SHOWVERSION	0x60	Report firmware version string (currently SG15V03.14) to host application
C_REROUTE	0x70	Reroute Ethernet/WLAN communication to serial port: Not Implemented
C_PULSE <sup>3</sup>	0x7C	Activate Exit Gate relay for 0,5 sec. The SG-15 will reply an ACK (0x06).

1) The SG-15<sup>Colour</sup> has an advanced standby scheduler that can be programmed in days/hours/minutes.

2) Ditto 1

3) Requires special SG-15<sup>Colour</sup> Entry/Exit Gate Terminal hardware. "EG" on unit serial number label.

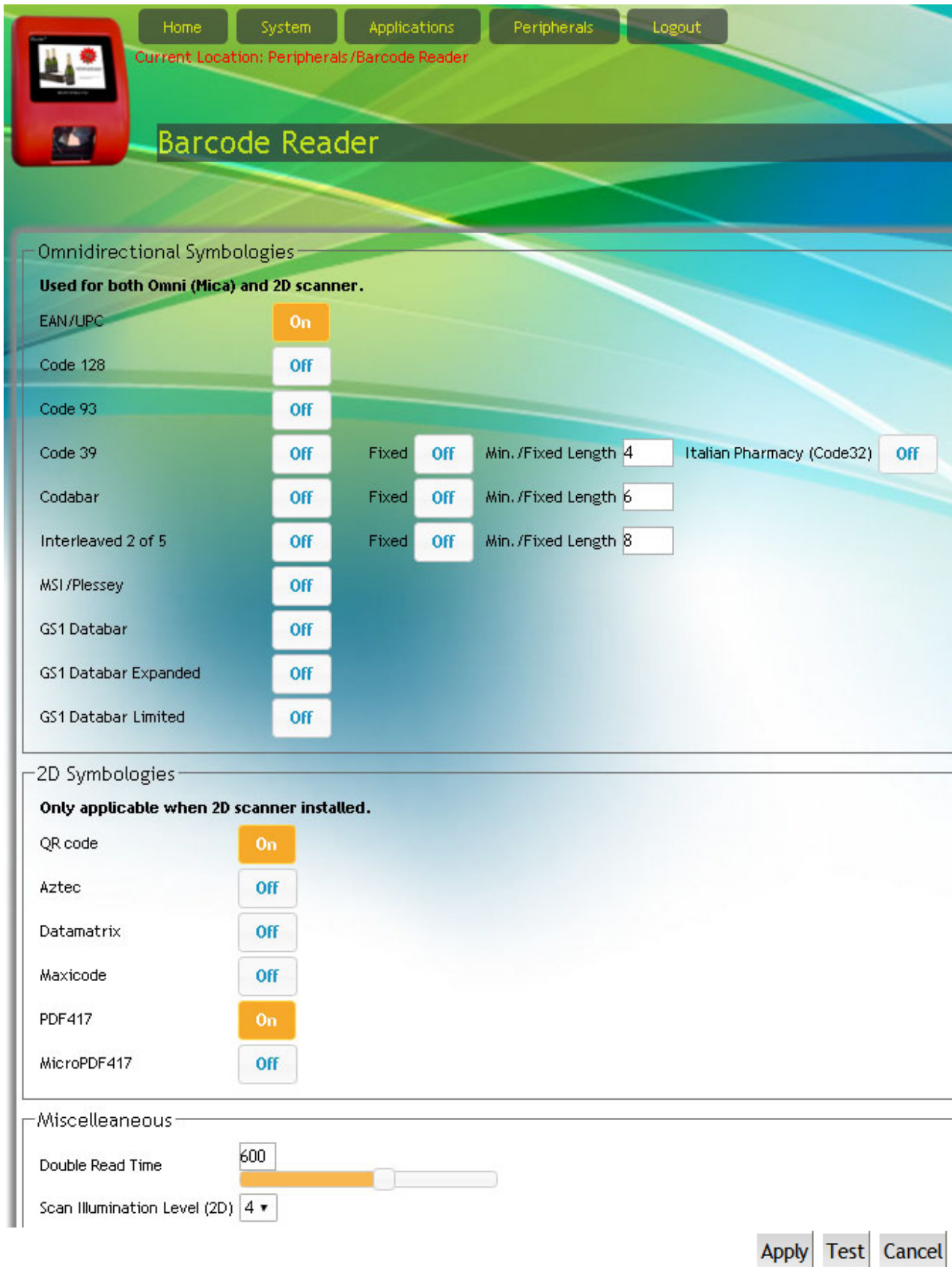

The image shows a web-based configuration interface for a Barcode Reader. At the top, there is a navigation bar with buttons for Home, System, Applications, Peripherals, and Logout. Below this, a breadcrumb trail indicates the current location: Peripherals / Barcode Reader. A red image of the barcode reader device is shown on the left. The main title is "Barcode Reader".

The interface is divided into three sections:

- Omnidirectional Symbologies**: Used for both Omni (Mica) and 2D scanner. It lists various symbologies with toggle buttons (On/Off) and additional settings for some.

Symbology	Toggle	Fixed	Min./Fixed Length	Additional Settings
EAN/UPC	On			
Code 128	Off			
Code 93	Off			
Code 39	Off	Off	4	Italian Pharmacy (Code32) Off
Codabar	Off	Off	6	
Interleaved 2 of 5	Off	Off	8	
MSI/Plessey	Off			
GS1 Databar	Off			
GS1 Databar Expanded	Off			
GS1 Databar Limited	Off			
- 2D Symbologies**: Only applicable when 2D scanner installed. It lists 2D symbologies with toggle buttons (On/Off).

Symbology	Toggle
QR code	On
Aztec	Off
Datamatrix	Off
Maxicode	Off
PDF417	On
MicroPDF417	Off
- Miscellaneous**: Contains two settings:
  - Double Read Time: A numeric input field set to 600 and a corresponding slider.
  - Scan Illumination Level (2D): A dropdown menu set to 4.

At the bottom right, there are three buttons: Apply, Test, and Cancel.

## Chapter 5.5 Configuring the Barcode Reader

### Introduction

The SG-15<sup>Colour</sup> is equipped with a barcode reader of type Omni-Laser, CCD Single Line or 2D Imager. At startup, the SG-15<sup>Colour</sup> detects what type of barcode reader is installed and it will auto-configure the device according the settings on the Barcode Reader page.

### Double Read Time

This time value (in milli seconds) represents the minimum time between reading one and the same barcode twice. The minimum time for reading two different barcodes after each other is less than 200 msec for an Omni scanner.

### Scan Illumination Level

For reading barcodes in a dim lighted environment, extra illumination is needed for the 2D scan-engine. The illumination is adjustable and the number of levels depends on the 2D scan-engine (max. 5 levels, including illumination=Off). Use the **Test** button to check the adjusted level and then **Apply**.

### Notes

1. 2D symbologies settings are ignored by the omni-directional reader.
2. Since the bar code reader page is not meant to replace the reader Configuration Manual, only the most important symbology settings can be changed.
3. The SG-15<sup>Colour</sup> fully manages the scan engine settings. It is advised against to configure the scanner manually.

Home System Applications Peripherals Logout

Current Location: Applications/Desktop Configurator

## Desktop Configurator

You Can Change File Location By Drag & Drop.  
You Can Delete The File By Clicking The Icon

Upload Directory Size 130928 Kb

Maximum Available Size 1797984 Kb

### Informations

Path	
SG	



## 5.6 Desktop Configurator Which application starts at power up

Through the Desktop Configurator you select which application starts after power-up.

WebPriceChecker:



the default application at start-up,  
as of firmware version V093

or

SGPriceChecker:



Procedure to select the SGPriceChecker as the start-up application,  
for SG-15<sup>Plus</sup> Compatibility Mode:

- See web page Applications/DeskTopConfigurator (illustration left)
- Click on the SG icon
- Edit item
- app/sgpricechecker is selected and
- Set to Start at Boot
- Accept

Illustration:

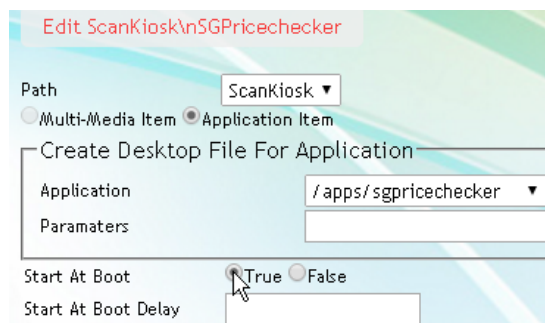

+



The WebPriceChecker application must be turned off.

### Note:

Desktop settings are saved in the **Templates** section.

For any desktop setting you want to install on other SG's, go to page « [System -> Templates](#) », select « [Save Customer Templates](#) » and « [Create & Download Template Package](#) ». The latter action downloads a file *sk-customer-templates-name\_0.9.n\_armhf.deb* to your PC/laptop.

Home System Applications Peripherals Logout

Current Location: Applications/Web Price Checker

# Web Price Checker 1.3.3

Start Page: file:///apps/config/skweb\_welcome.{@SKTYPE}.html

Welcome Page: file:///apps/config/skweb\_welcome.{@SKTYPE}.html

Welcome Timer: 10

Query Url: http://www.i-rk.nl/SG-15ColourDemoWebPriceChecker/{@BARCODE}

Error Page: file:///apps/config/skweb\_error.{@SKTYPE}.html

Allow URL barcodes:  On

Accepts:

- 1D Barcodes:  On
- 2D Barcodes:  Off
- RFID Tags:  Off
- Others:  Off

Apply Cancel

## Chapter 5.7 Web Price Checker

### Introduction

To make the Shuttle long term future proof the SG-15<sup>Colour</sup> features the valuable Web Price Checker application, which is standard on board as of firmware V093.

These are the **Features** and **Benefits**:

- Easy integration of the SG-15 in the Retailers IT structure, using HTML web standards.
- Central Management of SG-15 screen content
- Natural and easy use of colours on the SG-15 screen
- Built-in Price Check demo on board. Straight from the box. No configuration required.

The web based price-checker uses a web-kit library to setup a browser-like connection to an http server. When a bar code is scanned, the SG-15<sup>Colour</sup> will send the scanned data as an HTTP request to a web server. The web server is responsible for generating the HTML page with Article/Price/Picture content, which is sent to the SG-15<sup>Colour</sup>. The web-kit utility executing on the SG-15<sup>Colour</sup> will interpret and show the content on the display.

### 1. START PAGE

Default, the URL of the **Start** Page and **Welcome** Page are defined as HTML files residing on the SG-15<sup>Colour</sup>. The **Start** page is only displayed at start-up of the Web-Price-Checker application. Having these files local on the SG-15<sup>Colour</sup> guarantees that the SG-15<sup>Colour</sup> starts with a non-empty page (even if the web-server is temporary out of service).

### 2. WELCOME PAGE

The welcome page shown in between barcode scans when the SG-15<sup>Colour</sup> is in idle state. The URL may refer to a local file or to an external (web) server.

### 3. WELCOME TIMER

After a scan and a successful article look-up, the server replies with an article description, price etc. This information is displayed on the screen for the number of seconds specified in the **Welcome Timer** field. When this timer times out, the SG-15<sup>Colour</sup> enters an idle state and normally it will re-display the Welcome Message

#### 4. Query URL

For every scanned barcode, the SG-15<sup>Colour</sup> sends a query URL with the requested barcode information to the web server. The Web-Price-Checker uses tag-variables in the URL for this, like for example:

<http://www.i-rk.nl/SG-15ColourDemoWebPriceChecker/{@BARCODE}>

When scanning an EAN-13 barcode **5029053021454** on the SG-15<sup>Colour</sup>, the URL request with variables, `{@SG-15C}` and `{@BARCODE}` will be reformatted and send to the web server as:

<http://www.i-rk.nl/SG-15ColourDemoWebPriceChecker/5029053021454>

Note that the sequence of the variables `{@BARCODE}` and `{@SG15C}` in the specified URL, must match with the search path on the web server.

This URL refers to a local file with error message which you can customize. Using a local file as URL for error message has the advantage that an error message is also displayed when the web server is not responding i.e. offline.

#### 4. Allow URL barcodes

This feature is useful for scanning 2D-barcodes on products or leaflets with 2D-barcodes that represent a URL referring directly to a site on the internet or intranet. When this feature is ON and your SG-15<sup>Colour</sup> is equipped with a 2Dscanengine (or alternatively: a 2D handscanner connected to the USB port), then scanning the QR-code below will show the following response on the display:

QR-code with URL <http://www.scantech->

[id.com/en/products/details.php?pin=86de2bcc12608c9cbeecd9f5a63312c8b](http://www.scantech-id.com/en/products/details.php?pin=86de2bcc12608c9cbeecd9f5a63312c8b)

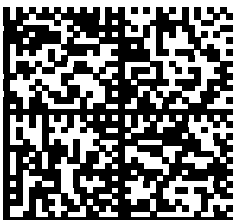

Scan QR code →

The screenshot shows the Scantech ID website interface. At the top, there is a navigation bar with links for Home, About us, Products, News, Where to buy, Support, Partner Login, and Contact us. A search bar is located on the right. The main content area displays the product page for the SG-15 Colour scanner. On the left, there is a sidebar menu with categories like Scan-Kiosks, Price Checkers, Desktop Scanners, In-counter Scanners, Gun-type Scanners, 2D Gun-Type Scanner, Laser Scanner, Wireless Pocket Scanner, and Champtek Products. The main product image shows a red SG-15 Colour scanner with a display screen. Below the image, there are tabs for Overview, Features, and Specifications. The text below the image describes the scanner's features, including its entry-level design, bright display, and high performance.

## 5. URL tag-variables recognized by the URL parser

Tags according {@...}	Description:	Required:
BARCODE	Barcode as read by scan-engine (without identifiers)	Mandatory
Product TYPE	Type of ScanKiosk: SK-40, SK-40 or SG15C	Optional
WIDTH	Pixel width of the skweb-screen	Optional
HEIGHT	Pixel height of the skweb-screen	Optional

### Notes:

1. The web server is responsible for generating a web page with 320X240 resolution. Side scroll-bars will appear on the display when the page is too large for the actual display.
2. The URL's starting with *file:///apps/config/*, refer to local HTML file which you can modify by using the download and upload interfaces on web page *Templates*.
3. To leave the Web-Price-Checker application, you need to scan the special barcode in Appendix N.
4. New configuration settings become effective only after a restart of Web Price Checker.
5. On request, Scantech-ID can provide an open source **Web Server Demo** application XAMPP that installs on a standard PC/Laptop, running Windows or Linux. This demo application contains a small SQL-database which is accessed through an Apache web server.

## Chapter 5.7.1 On-Line Demo Website for Web Price Checker Application

The most modern integration method of the SG-15<sup>Colour</sup> Price Checker is using the **Web Price Checker** application, which is standard available on the SG-15<sup>Colour</sup>, as of firmware version V093. The name of this application speaks for itself. In fact this is: "**Cloud Based Price Checking**" i.e. without the need of a local store server.

To Live demonstrate the use of the WebPriceChecker there is demo website on line. These are the user instructions:

1. Connect the SG-15<sup>Colour</sup> to your local network (Ethernet or WiFi) with Internet access. The use of DHCP is recommended.

2. The Default value Query Url (above)

[ i.e.: <http://www.i-rk.nl/SG-15ColourDemoWebPriceChecker/{@BARCODE}> ]

has been configured by default to immediately work.

This means the SG-15<sup>Colour</sup> is ready for demonstration straight from the box, without any configuration, if connected to the local network with Internet access.

Scan one of the bar codes on the left side page

Demo Code

Response on SG-15 screen



**Billy** Classic Swedish Design



Bokhylla, björkfäner  
Med smala hyllor utnyttjar  
effektivt mindre väggytor  
läter de små sakerna ta

395 kr

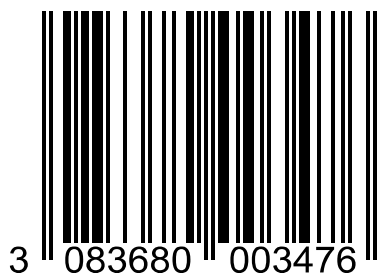

**Jean Paul GAULTIER**

Le Male  
Eau de Toilette for Men  
by Jean Paul Gaultier

à partir de € 41,90



Dallmayr  
prodomo  
500 gr  
€ 4,79

EAN 4008167103714



**Kleenex Tissues**

Box of 90 pcs Balsam tissues  
Thai: สีนุ่มซี่  
Chinese: 薄紙  
Russian: Салфетки

€ 1.74





## **Chapter 6 Maintaining the Shuttle<sup>c</sup>**

---

## 6.1 CLEANING

The Shuttle<sup>c</sup> requires little maintenance. Only occasional cleaning of the scanner and display window is necessary to remove dirt and fingerprints. Cleaning can be performed during operation with a non-abrasive glass spray cleaner and a soft lint-free cloth.

Clean the cover and window of the Shuttle<sup>c</sup> every now and then. Take care of the following:

- Use a mild glass spray cleaner;
- Spray the cleaner on a soft, lint-free cloth;
- Wipe the Shuttle<sup>c</sup> clean.

### **IMPORTANT**

- Clean the scanner window with care.

### **IMPORTANT**

The exterior of the Shuttle<sup>c</sup> should NOT be cleaned with cleaners containing:

- Aromatic hydrocarbons
- Chloride
- Acids, oxidizing agents
- Abrasives
- Other aggressive cleaners

## Appendices

---

A	Connector types and pin definitions.....	59
B	Controlling the display and Shuttle <sup>c</sup> terminal.....	60
C	Character sets.....	61
D	Factory Default Settings.....	69
E	Updating Applications or System Packages.....	70
G	Frequently Asked Questions.....	71
H	Shuttle <sup>c</sup> Project tasks.....	75
I	Technical specifications.....	76
J	Overview Partnumbers.....	78
K	Simple Shuttle <sup>c</sup> Demo Programs.....	79
L	WiFi info .....	81
N	Shuttle <sup>c</sup> Control Bar Codes.....	82
P	Drilling Template for Easy Mounting.....	85
Q	Product Summary What's new at the SG-15 <sup>Colour</sup> .....	86

## APPENDIX A PIN DEFINITIONS AND CONNECTOR TYPES

### Physical Connections

#### Ethernet Connector

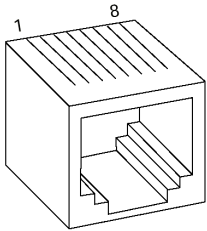

- 1 - Tx<sup>C</sup>
- 2 - Tx-
- 3 - Rx<sup>C</sup>
- 6 - Rx-

Cable between Shuttle<sup>C</sup> and network connection:

Use a standard, '8 pin', 1-to-1 Ethernet network cable to connect the Shuttle<sup>C</sup> to your Ethernet network.

#### Important

Make sure you apply proper cabling when using the SG-15<sup>Colour</sup> Power-over-Ethernet version (IEEE802.3af PoE). PoE uses either the 4 data lines (1,2,3,6), called End-Span, OR the not used lines (4,5,7,8), called Mid-Span. Which method is used, depends on the supplying network switch. The Shuttle<sup>C</sup> SG-15<sup>Colour</sup> supports both methods automatically.

#### DC Power connector

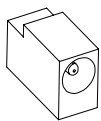

- 1 GND
- 2 +5 VDC



Front view

#### USB Connector

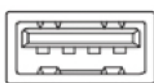

Contact our Technical Support for the technical details on connecting a handscanner to the USB Port.

**See Chapter 1.4 for the physical location of the connectors.**

## Appendix B Controlling the Display and Shuttle<sup>c</sup> terminal

### Introduction

The SG-15<sup>Colour</sup> acts a normal remote terminal; Every received ASCII value (between 20 and 255), which isn't part of a command, is normally displayed on the screen.

Furthermore, the Shuttle<sup>c</sup> is controllable and easily configurable by means of ESC (Escape) commands to customize the following parameters;

- Cursor Control
- Clearing the Display
- Aligning Text

You can remotely turn OFF and ON the Shuttle<sup>c</sup> from the Back-Office application by ESC commands. It is strongly recommended to use this feature, during the stores' closing hours and when the article database is not available. It will save energy, extend the lifetime of the Shuttle<sup>c</sup> and shows a sustainable system design.

### **"The SG-15<sup>Colour</sup> The Green Price Checker".**

In addition: Thanks to the Real-Time Clock and the Stand-By Scheduler the SG-15<sup>Colour</sup> can be set to turn off during the store's closing time, to reduce the power consumption to a minimum and to extend the product lifetime.

Due to the fact that the SG-15<sup>Colour</sup> uses proportional fonts (every single character has it's own specific width), you never know precisely how much characters fit on one line. Therefore, when a character doesn't fit on the current line, it's not displayed at all (instead of printing it on the next line, which gives undesired "messy" results)

You can move to another line by sending a Carriage Return (0x0d), or a Linefeed (0x0a). Both have the same effect: Going to the start position of the next line).

You can move the cursor by sending:

- 'Set cursor' command (ESC 0x27), for predefined cursor positions.
- 'Set Pixel Position' command (ESC 0x2C),  
for placing the cursor on any pixel location.

For easy alignment of text on often desired positions (like the center of the screen, right of the screen, bottom of the screen, etc) you can use the 'Align text' (ESC 0x2e) command.

At the end of this Appendix you find the complete command set, including the sub-parameters.

On the next pages, you find some examples to give an impression of the way you can use the display of the SG-15<sup>Colour</sup>. These examples are also shown when using the -simple- demo program SG15Demo.exe. See Appendix K.

Note: <ESC> should be sent as the hexadecimal value 1B.

Note: The notation of e.g. 0x24 means the hexadecimal value 24.

### Example 1

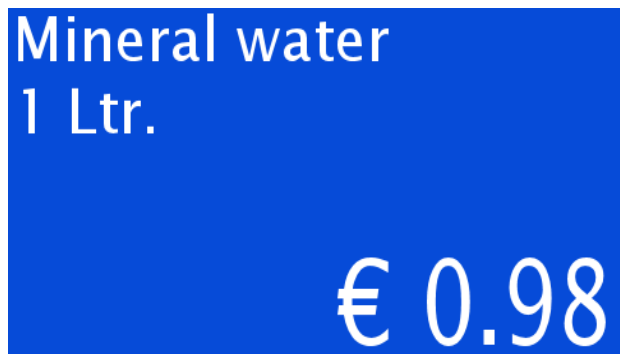

**How to create this screen:**

COMMAND or data string	COMMENT
<ESC> 0x42 0x30	Set font size 0
<ESC> 0x25	Clear the screen, cursor top left
"Mineral water"	Print text
0x0d	Carriage Return = Next line
"1 Ltr."	Print text
<ESC> 0x42 0x31	Font size 1
<ESC> 0x2e 0x38 "€ 0.98" 0x03	Align text to right bottom

**Example 2**

How to create this screen:



COMMAND or data string	COMMENT
<ESC> 0x42 0x30	Set font size 0
<ESC> 0x25	Clear the screen, cursor top left
<ESC> 0x2e 0x31 "Coca Cola 0.33Ltr" 0x03	Align text to center - top
<ESC> 0x2c 0x30 0x45	Set cursor to pixel position (0,21)
<ESC> 0x2e 0x3a "€2.69 (Crate)" 0x03	Align text to horizontal center
<ESC> 0x42 0x31	Set font size 1
<ESC> 0x2e 0x37 "Special Offer !" 0x03	Print text and align text to bottom center

**Example 3**

How to create this screen:



COMMAND or data string	COMMENT
<ESC> 0x42 0x30	Set font size 0
<ESC> 0x25	Clear the screen, cursor top left
<ESC> 0x2e 0x30 "Winner" 0x03	Align text to left - top
<ESC> 0x2e 0x32 "Winner" 0x03	Align text to right - top
<ESC> 0x2e 0x36 "Winner" 0x03	Align text to left - bottom
<ESC> 0x2e 0x38 "Winner" 0x03	Align text to right - bottom
<ESC> 0x42 0x31	Set font size 1
<ESC> 0x2e 0x34 "You Win!" 0x03	Align text to center



## SG-15 Command Set

SCANTECH ID				V2.0		
				This command set refers to SG15 <sup>plus</sup> firmware version 3.03 and higher.		
COM MAND	SUBCOMMAND			DESCRIPTION	PARAMETERS	
	ESC (1B)16	HEX	DEC			
ESC	24	36	\$	<i>reserved</i>		
ESC	25	37	%	Clear Display Clear the Display and move the cursor to the topleft position		
ESC	27	39	'	Set Cursor Position Set the cursor position on the display. Note : The actual pixelposition depends on the currently selected font set: Every x-position is a multiple of 8 pixels. Every y-position depends on the currently selected font set (height of 12 or 21 pixels)  Pos : 0 - 15 (0x30 - 0x3F) Line : 0 - 4 (0x30 - 0x34)	<POS> 0x30-0x3F	<LINE> 0x30-0x34
ESC	2C	44	,	Set Pixel Position Set the current pixel position on the display. This allows a text to be printed anywhere on the display.  Pos : 0 - 127 (0x30 - 0xAF) Line : 0 - 63 (0x30 - 0x6F)  Note : A character will only be displayed on the current coordinates if it fully fits on the screen.	<POS> 0x30-0xAF	<LINE> 0x30-0x6F
ESC	2E	46	.	Align a string of text Print a text, using the current font set, on a calculated position on the screen.  <Align> can be one of the following values: 0x30 - Left Top 0x31 - Center Top 0x32 - Right Top 0x33 - Left Center 0x34 - Center Center 0x35 - Right Center 0x36 - Left Bottom 0x37 - Center Bottom 0x38 - Right Bottom 0x39 - Left, using current y-coordinate 0x3A - Center, using current y-coordinate 0x3B - Right, using current y-coordinate 0x3C - Top, using current x-coordinate 0x3D - Center, using current x-coordinate 0x3E - Bottom, using current x-coordinate  <Data> This field has a maximum length of <b>75</b> characters. Use 0x03 (ETX) as last char, if less characters are used.	<ALIGN> 0x30-0x3E	<DATA> "..." [0x03]

ESC	40	64	@	Sleep Clear display and Turn off Laser, Motor and Backlight. SG15 <sup>plus</sup> keeps functioning as normal.	
ESC	41	65	A	Wake Up Return from sleep	
ESC	42	66	B	Select Font Set The SG15 <sup>plus</sup> has 2 internal font sets: 0x30 - Font set 1 (Normal sized font) 0x31 - Font set 2 (Large font)	<FONTSET> 0x30-0x31
ESC	58	88	X	Show GIF Displays a GIF on the screen. GIFs and Text can be combined on one screen. The GIF can either be animated or static. Image#1 is the same image as used for the Idle screen.  A displayed image will be cleared after THold seconds (see Manual)  GIFs should be uploaded using tftp. Example: Upload file "image.gif" to image position 2: "tftp -i 192.168.3.227 put image.gif /gif2"	<IMAGE> 0x31-0x34.
ESC	5A	90	Z	Reset Soft reset	
ESC	5B	91	[	Enable/Disable scanning Enable or disable barcode scanning	<MODE> 0x30=disable 0x31=enable
ESC	5C	92	\	Enable/Disable Backlight The backlight will be turned on or off	<MODE> 0x30=off 0x31=on
ESC	5D	93	]	Sleep/Wakeup internal barcode scanner Put the internal barcode scanner into sleep (turn off laser and motor), or wake it up	<MODE> 0x30=sleep 0x31=wakeup
ESC	5E	94	^	Beep The internal speaker will generate the default 'beep'.	
ESC	60	96	`	Get Firmware Version The SG15 <sup>plus</sup> returns the current firmware version. Format "SG15Vnn.nn"	
ESC	70	112	p	Reroute Ethernet/WLAN communication Can be used to directly communicate with devices on a serial port. Normally, the data is printed on the display.  The SG15 <sup>plus</sup> will respond by sending an 'ACK' (0x06) back to the host.	<Destination> 0x30 = Display 0x31 = Ser.Port 1
ESC	7C	124		Only for Exit/Entry Gate Terminal use (special hardware configuration). The galvanic isolated switch will be closed during 500 milliseconds. The physical connection is available at the back of the special SG15.  The SG15 <sup>plus</sup> will respond by sending an 'ACK' (0x06) back to the host.	

All not mentioned commands are reserved for possible future use.  
Do not implement these in your application.





## APPENDIX D FACTORY DEFAULT SETTINGS

Currently, the Factory Default Settings are as follows:

DHCP	Enabled
IP Address (when no DHCP service)	192.168.1.200
Subnet mask	255.255.255.0
Default Gateway	192.168.1.254
IP Address Remote Host	192.168.2.60 (SGPriceChecker appl.)
TCP Port	9101
UDP Port	9101
Baudrate internal scanner	9600
TCP Connect Mode	Client
Wait for host after scanning barcode	3 seconds "
Display Message Timeout	5 seconds "
Font Code page	UTF-8 (Unicode Transformation Format)
WiFi mode	Infrastructure
WPA Key	empty
WiFi SSID	empty
WiFi Authentication	wpa-psk
Real time clock	NTP Client enabled, Universal timezone
Bar Code Symbologies active	EAN-13, EAN-8, UPC-A, UPC-E (omni-directional scanner)

The SG-15<sup>Colour</sup> can be returned to Factory Default Settings by:

- the button on the Main:System Configuration Page or
- the special barcode in Appendix N.

## APPENDIX E UPDATING APPLICATIONS OR SYSTEM PACKAGES

Here you find the procedure to update Application or System Packages:

### Step Explanation

- 1 Login on the SG-15 and navigate to the Package Manager page
- 2 Choose File
- 3 Locate the file [name]\_[version]\_ armhf.deb and click Apply
- 4 Response, indicating the package is transferred, unpacked and installed: The time depends on the nature of the package.
- 5 Positive acknowledgment:
- 6 Reboot the SG-15

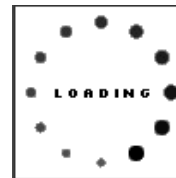

## APPENDIX G FREQUENTLY ASKED QUESTIONS

### INDEX

1. General
2. SG-15<sup>Colour</sup> Configuration and the SG-15<sup>Colour</sup> User's Manual
3. Networking
4. Demo-possibilities and how to get started
5. Barcodes

### G-1 GENERAL

*What is the standard available configuration and looks for the Shuttle<sup>c</sup>?*  
See Appendix J.

*Can we have other colours than black, Silver or Red?*  
Yes, other colours are only available on request, only in large quantities and under specific conditions.

*Is every Shuttle<sup>c</sup> delivered with a CD-ROM and User's Manual?*  
To save our natural resources, we do not include a User's Manual and Product CD with every unit anymore. The Product Support Library is available through FTP link.

*Why isn't there a "PC-board" inside the Shuttle<sup>c</sup>?*  
It was our design strategy to develop a compact, cost-effective entry level Price Checker, offering all the requirements for basic function, at absolute maximum reliability at a low power consumption and for an attractive price. We ensured the availability of the SG-15 motherboard for the future.

## **G-2 SG-15<sup>Colour</sup> CONFIGURATION AND THE SG-15<sup>Colour</sup> USER'S MANUAL**

*How do I configure the Shuttle<sup>c</sup>?*

The SG-15<sup>Colour</sup> has an internal web server, which makes it possible to configure it using any internet browser.

See Chapter 5 providing you with all details.

*Where do I find the most recent Shuttle<sup>c</sup> Command Set?*

In this manual (Appendix B) and in the Product Support Library.

*Do I need special software for the Shuttle<sup>c</sup>?*

The Shuttle<sup>c</sup> itself is standard equipped with all required firmware:

Linux OS, drivers and two applications for Price Check function.

On the server-side (your back-office system) a small program or routine is required to take care of the communication and to provide the product information that the Shuttle<sup>c</sup> shall display.

It is the role of the System Integrator to add his value here.

See Chapter 4 and software examples, including free source code of the complete (demo) application in the Product Support Library!

## **G-3 NETWORKING**

*Which type of Power Over Ethernet (PoE) is supported?*

The Shuttle<sup>c</sup> supports both Mid- and End-span connections, according to the IEEE 802.3af specifications.

*Which Wireless options are available?*

The SG-15<sup>Colour</sup> Shuttle<sup>c</sup> WiFi version supports IEEE 802.11 a/b/g/n/ac

See Appendix J for the SG-15<sup>Colour</sup> Partnumbers.

## **G-4 DEMO POSSIBILITIES & HOW TO GET STARTED**

*What kind of development package does the system-integrator get from*



### *Scantech-ID?*

The Shuttle<sup>®</sup> Product Support Library contains lots of technical information and free source code examples in all popular languages.

*Does the Shuttle<sup>®</sup> have an internal memory for an article database?*

No, we have chosen not to do this for the following reason:

It is crucial that the information given to the consumer on the Shuttle<sup>®</sup> display is correct. The best solution to achieve this high level of data integrity is to take the information from ONE central source:

The POS article database on the store's Back Office computer.

In case the Shuttle<sup>®</sup> terminal would contain a local database, this needs permanent maintenance, generating lots of data traffic and hassle.

Also, a local database memory will significantly increase the unit hardware costs.

*How can I give a quick demo?*

1. By using the WebPriceChecker app together with the on-line demo website. Chapter 5.7.1 describes all details.
2. See Shuttle<sup>®</sup> Product Support Library (Demonstration Tool\SG15Demo.exe). The SG-15<sup>Colour</sup> should run in TCP Server mode to work with this demo tool. See Appendix K for User Instructions.

*How can I give an advanced demo including my own database with demo articles?*

See Shuttle<sup>®</sup> Product Support Library (\Source Code Examples\Enhanced).

The SG-15<sup>Colour</sup> should run in TCP Client mode to work with this demo tool.

## **G-5 BARCODES**

*Which barcode symbologies does the Shuttle<sup>®</sup> read?*

Basically all popular symbologies as accepted by the integrated Scantech scanner: EAN 13, EAN 8, UPC A, UPC E, Add-ons, Code/EAN 128, Int 2/5, Code 39 (full ASCII), Code 32, Codabar and GS1-Databar (most popular types). By Factory Default EAN-13/8 and UPC-A/E decoding is activated.



## H SHUTTLE<sup>c</sup> PROJECT TASKS

The integration of a Price Checker like the Shuttle<sup>c</sup> into a store IT system is slightly more complex than linking a mouse to your PC. Therefore you find below -to prevent any miscommunication- a general guideline describing “Who Does What While Launching A Shuttle<sup>c</sup> Project”.

### **Scantech supplies:**

- Shuttle<sup>c</sup> Hardware Configuration (excl. network cabling).
- Overview of possibilities, features and benefits of the Shuttle<sup>c</sup>.
- Advice which Configuration to choose.
- FOR FREE: Examples of software source code for the application software plus Ethernet driver in the Product Support Library.
- Consultancy & Technical Support.

### **The Scantech Distributor / System Integrator supplies:**

- The application software linking the Shuttle<sup>c</sup> to the Customers' Product Database. See Chapter 4.1.
- Choice of the configuration, depending on:
  - Requirements of the end-user.
  - Current Installation.
- Installation of the Shuttle<sup>c</sup> terminals and the network-cabling.
- Shuttle<sup>c</sup> field-service, implying:
  - Configuration of the Shuttle<sup>c</sup> terminals prior to installation, with the built-in web server.
  - One minute swap time due to smart mounting (no need to open the Shuttle<sup>c</sup>).

## APPENDIX I TECHNICAL SPECIFICATIONS

<b>Electrical</b>	
Power supply voltage	100-240 VAC 50/60 Hz through external PSU (adapter) or Power over Ethernet complying IEEE 802.3af (optional)
Power consumption	3.25 Watt (5Vdc, 650 mA). At nominal configuration: Omni laser scanner and Ethernet interface. USB port unused.
Shuttle <sup>c</sup> DC input	+5 V
Interfaces	Standard Ethernet, Wireless IEEE 802.11 a/b/g/n/ac (optional) or Power over Ethernet IEEE 802.3af POE (optional)
<b>Scanner characteristics</b>	
Light source	Visible laser diode (630 – 670 nm) or red LED
Depth of field	200 mm (= maximum reading distance)
Scan pattern	Omnidirectional laser pattern, single line CCD or 2D Imager
Bar code types	<p><b>*Omni Directional Laser Scanner:</b> EAN/UPC/JAN+Add-on, ISBN, Code 128, EAN128, Code 93, Code39, Code32, Codabar, Interleaved 2 of 5, MSI-Plessey and GS1 DataBar.</p> <p><b>*Single Line CCD Scanner:</b> All UPC/EAN/JAN, EAN128 Code, Code 39, Code 39 Full ASCII Code32 / Italian Pharmacy, Code 128, CODABAR/NW7, Interleaved 2 of 5, Industrial 25, Matrix 25, MSI/PLESSEY, Telepen, Code 93, Code 11, China Postage, Code 26, LCD25 and GS1 DataBar Family.</p> <p><b>*2D Imager:</b> 1D Symbologies: EAN/UPC, Australian Post, Aztec, BPO, Canada Post, Dutch Post, EAN.UCC Composite, Interleaved 2 of 5, Japan Post, MSI Code, Planet, Plessey Code, Postnet, GS1 Databar, Standard 2 of 5, Telepen, TLC39 2D Symbologies: Datamatrix, Matrix 2 of 5, Maxi 2 of 5, Maxicode and QR code</p>
<b>Physical</b>	
Dimensions	182 (h) x 131 (w) x 95 (d) mm
Display	TFT-LCD Size 3.5" diagonal 320X240 pixels QVGA 70 X 53 mm Color depth 16.7M Colors 450 nits High brightness Wide viewing angle
Housing	PC/ABS

<b>System Architecture</b>	
Processor	ARM Cortex-A7 Dual-Core
Operating System	Standard Linux (Kernel > 3.0)
Memory Flash	2GB expandable with USB flash drive and SD card
Memory RAM	512MB
Software	Client Applications included

<b>Environmental</b>	
Operating temperature	0°C ... 40°C
Humidity	20% .. 95% RH (non condensing)

<b>Safety/EMC</b>	
Laser Safety	IEC 825-1 (1993) Class I, U.S. 21CFR1040 Class IIa
Electrical Safety	LVD-EN60950-1
EMC	EN5022 CLASS A:2010/AC:2011 EN61000-3-2: 2014 EN61000-3-3: 2013 EN55024:2010 IEC 61000-4-2:2008 IEC 61000 3: 2006+A1:2007+A2:2010 IEC 61000-4-4:2012 IEC 61000-4-5:2014 IEC 61000-4-6:2013 IEC 61000-4-8:2010 IEC 61000-4-11:2004
CE	RED EN300328(1.9.1) RED EN301489-1/EN301489-17 EN301893 RF-WLAN UNII BAND 1 (ac) EN301893 a WLAN
FCC	FCC Part 15C FCC Part 15B RF-WLAN 802.11a (W52/W53) RF-WLAN 802.11ac (W56 )

## APPENDIX J OVERVIEW PARTNUMBERS

<b>Shuttle<sup>c</sup> with Omni-Directional Laser -MICA- Scanner</b>	<b>Shuttle<sup>c</sup> with Single Line -CCD- Scanner</b>
<p><i>Standard version with Ethernet:</i></p> <ol style="list-style-type: none"> <li>1. 718A7 G0104 E2000 Black Ethernet</li> <li>2. 718A7 00404 E4000 Silver Ethernet</li> <li>3. 718A7 00300 E0000 Red Ethernet</li> </ol> <p><i>Wireless LAN:</i></p> <ol style="list-style-type: none"> <li>4. 718A7 00104 W2000 Black WLAN</li> <li>5. 718A7 00404 W4000 Silver WLAN</li> <li>6. 718A7 00304 W0000 Red WLAN</li> </ol> <p><i>Power over Ethernet PoE 802.3af:</i></p> <ol style="list-style-type: none"> <li>7. 718A7 10104 M2000 Black PoE</li> <li>8. 718A7 10404 M4000 Silver PoE</li> <li>9. 718A7 10304 M0000 Red PoE</li> </ol>	<p><i>Standard version with Ethernet:</i></p> <ol style="list-style-type: none"> <li>1. 718A7 20104 E2000 Black Ethernet</li> <li>2. 718A7 20404 E4000 Silver Ethernet</li> <li>3. 718A7 20304 E0000 Red Ethernet</li> </ol> <p><i>Wireless LAN:</i></p> <ol style="list-style-type: none"> <li>4. 718A7 20104 W2000 Black WLAN</li> <li>5. 718A7 20404 W4000 Silver WLAN</li> <li>6. 718A7 20304 W0000 Red WLAN</li> </ol> <p><i>Power over Ethernet PoE 802.3af:</i></p> <ol style="list-style-type: none"> <li>7. 718A7 30104 M2000 Black PoE</li> <li>8. 718A7 30404 M4000 Silver PoE</li> <li>9. 718A7 30304 M0000 Red PoE</li> </ol>
<b>Shuttle<sup>c</sup> with 2D imager</b>	
<p><i>Standard version with Ethernet:</i></p> <ol style="list-style-type: none"> <li>1. 718A7 A0104 E2000 Black Ethernet</li> <li>2. 718A7 A0404 E4000 Silver Ethernet</li> <li>3. 718A7 A0304 E0000 Red Ethernet</li> </ol> <p><i>Wireless LAN:</i></p> <ol style="list-style-type: none"> <li>4. 718A7 A0104 W2000 Black WLAN</li> <li>5. 718A7 A0404 W4000 Silver WLAN</li> <li>6. 718A7 A0304 W0000 Red WLAN</li> </ol> <p><i>Power over Ethernet PoE 802.3af:</i></p> <ol style="list-style-type: none"> <li>7. 718A7 B0104 M2000 Black PoE</li> <li>8. 718A7 B0304 M0000 Silver PoE</li> <li>9. 718A7 B0404 M4000 Red PoE</li> </ol>	

## APPENDIX K SIMPLE SHUTTLE<sup>c</sup> DEMO PROGRAMS

There are two ways to demonstrate and test the Shuttle<sup>c</sup> in a simple way:

1. By using the WebPriceChecker app together with the on-line demo website.  
Chapter 5.7.1 describes all details
2. See Shuttle<sup>c</sup> Product Support Library (Demonstration Tool\SG15Demo.exe).  
The Shuttle<sup>c</sup> demonstration program SG15Demo.exe can be found in the Product Support Library (directory \Demonstration Tool).  
The SGPriceChecker must be selected as the active application.  
Ref: Chapter 5.4 and 5.6.

This program can be used for quick and easy demonstrations or for experimenting. You can see literally, what bar code data is transmitted by the SG-15<sup>Colour</sup> and how the product information and screen control is sent by the demo program to the SG-15<sup>Colour</sup>. Just connect to your SG-15<sup>Colour</sup> and try it.  
It's really that easy!

### Some notes:

1. Regarding the Network Connection Properties of your PC:  
Make sure the IP address of your PC is in the same IP range as the Shuttle<sup>c</sup> you want to communicate with.  
For instance by giving your PC IP address: 192.168.1.250.
2. Set the SG-15<sup>Colour</sup> in Server Mode as described in Chapter 5.4.
3. If this appears to be necessary: Add SG15Demo.exe in the list of Exceptions under Windows Firewall.

### Using the Demo program

When you scan a barcode at the SG-15<sup>Colour</sup>, the program responds with 1 of 5 predefined texts. Select the option 'Respond to barcodes'  
On the blue edit field you can actually see what exactly is received or transmitted.

You can manually enter text, which will be displayed on the SG-15<sup>Colour</sup> screen.  
Just click on the blue edit screen of this program and start typing.

**Don't forget to 'Connect' first!**

You can also give SG-15<sup>Colour</sup> Control (ESC) commands.  
Just hit the ESC key, which sends an actual esc-character (0x1b).

Examples:

**Clear the SG-15<sup>Colour</sup> screen:** Hit 'ESC' key  
Enter '%'

**Make the speaker sound** Hit ESC key  
Enter '^'

**Kick the Shuttle<sup>c</sup> into Sleep** Hit 'ESC' key  
Enter '@'

**Wake up the Shuttle<sup>c</sup> again** Hit 'ESC' key  
Enter Capital A

Consult Appendix B for more ESC command examples.



## **APPENDIX L WiFi info**

A short note on this SG-15<sup>Colour</sup> WiFi version:

To bring the SG-15 up to date regarding WiFi connectivity and to achieve the following goals:

- Support of modern 2016+ WiFi standard IEEE 802.11 a/b/g/n/ac
- More compact, less components and energy
- Use latest technology also applied in modern tablets and PC's
- Better continuity and long term availability,

the SG-15 WiFi technology is now soldered directly on the motherboard.

This may be hardware-wise less flexible, but provides you all above-mentioned advantages.

If you require the SG-15 WiFi, please order as per PartNumbers as specified in Appendix J.

## **APPENDIX M**

Intentionally left blank

## Appendix N SG-15<sup>Colour</sup> Control Bar Codes

To make live easier for those who test, install and maintain the SG-15<sup>Colour</sup>, we have implemented four Control Barcodes in the Shuttle:

### Reboot:

Will reboot the SG-15<sup>Plus</sup>

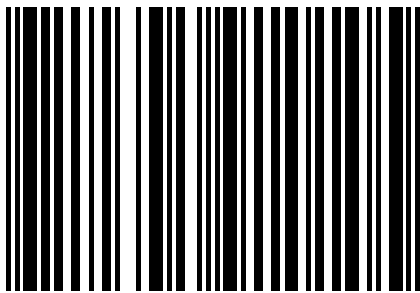

### Back to Default:

Load default parameter set

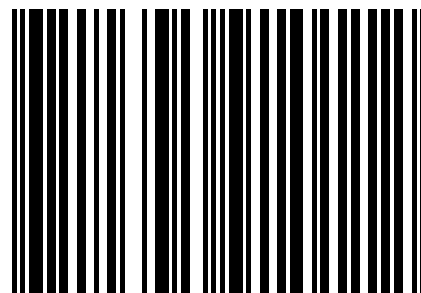

### Reboot to LAN:

- For WiFi testing purposes only.
- Reboots the SG-15 using LAN as the active interface to configure a WiFi unit.

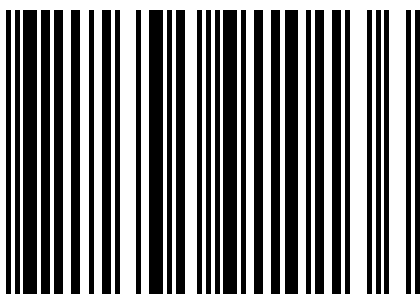

### Show the SG-15 status <sup>\*1</sup>

See explanation on the next page.

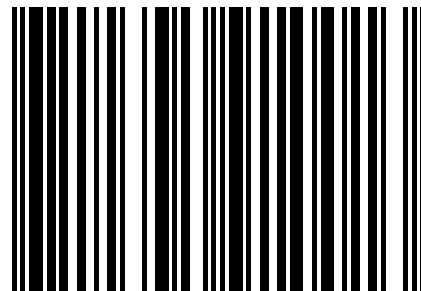

## \*1 Showing the SG-15 status

The Shuttle+ Price Checker is a kind of black box -from the outside-, where it concerns the primary network parameters.

In order to make Installation and Service easier, the Terminal Status Request by Bar Code feature has been implemented.

With the ultimate goal to decrease the Total Cost of Ownership.

### How does it work:

- Scanning this barcode at the ShuttleC will show its status and configuration info.
- This feature is reading-out info only. For security reasons we have chosen not to make the SG-15 parameters bar code programmable.

The Control bar code below will close the running application(s) and return the SG-15<sup>Colour</sup> to the DeskTop.

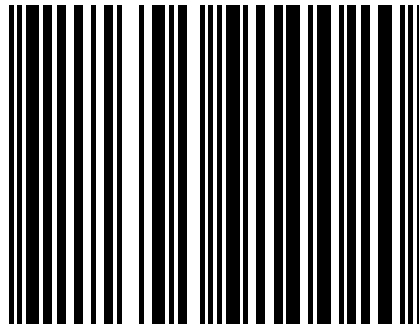



## Appendix P Drilling Template for Easy Mounting

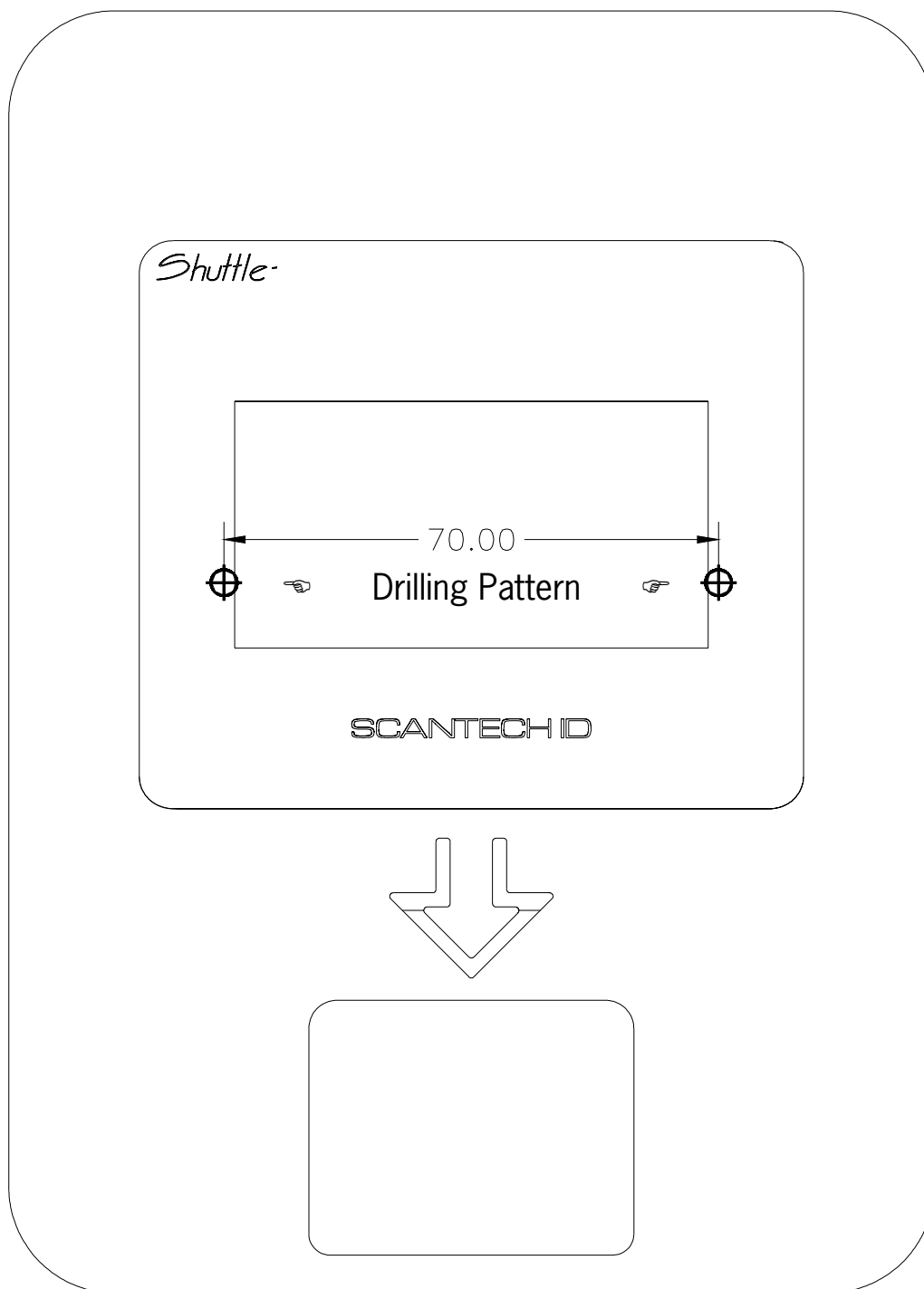

reference: 100 mm

- Print/Enlarge this page to the real product sizes of 182 X 131 mm
- Make sure the scaling reference of 100 mm is respected.

## Appendix Q Product Summary What's new at the SG-15<sup>Colour</sup>

Here is an overview of our objectives and the new major product characteristics:

1. Color screen 3.5" TFT-LCD 320X240 resolution. 16 million colours for high quality displaying. Wide viewing angle. A big step forward in readability.

SG-15 and SG-15<sup>Plus</sup>

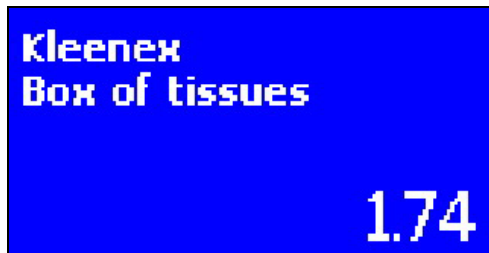

SG-15<sup>Colour</sup>



2. Embedded Linux OS for better and long term feature support
  3. Running on Dual-Core ARM processor
  4. Compatible with existing SG15<sup>Plus</sup> regarding communication protocol, Ethernet, WiFi and POE
  5. Remote unit configuration using modern web browser
  6. Application packages and system parts remotely upgradable
  7. The barcode scanner is configured through webbrowser instead of bar codes
  8. Creating custom lay-out of the Price-Check display
  9. Up-to-date WiFi technology supporting IEEE 802.11 a/b/g/n/ac, dual-band 2.4GHz/5GHz
  10. Handscanner connection now using USB instead of RS-232
  11. Real-time clock on board for automatic standby/wake-up, saving energy and product lifetime
  12. Web Price Checker application for remote content management and uptodate integration technology.
  13. 2D scan engine available at later stage.
- SG-15 housing, PSU and Ethernet network connection fully compatible with the previous SG-15 models.
  - All these actions were taken to continue and expand the enduring success in the market of the Scantech-ID Shuttle.



Scantech-ID BV  
Heliumweg 34 A  
3812 RE Amersfoort  
The Netherlands

Phone: +31 (0)33 469 84 00  
E-mail: [info@scantech-id.com](mailto:info@scantech-id.com)  
Internet: [www.scantech-id.com](http://www.scantech-id.com)  
[www.champtek.com](http://www.champtek.com)

---